

Rexroth IndraDrive Drive Systems with HMV01/02 HMS01/02, HMD01, HCS02/03

R911309636
Edition 06

Project Planning Manual



Title Rexroth IndraDrive
Drive Systems with HMV01/02
HMS01/02, HMD01, HCS02/03

Type of Documentation Project Planning Manual

Document Typecode DOK-INDRV*-SYSTEM*****-PR06-EN-P

Internal File Reference RS-133519800a6846ac00a015a26f840210-5-en-US-3

Record of Revision

Edition	Release Date	Notes
04	08/2007	-
05	09/2009	-
06	08/2013	Changes: See index entry "Changes"

Copyright © Bosch Rexroth AG 2013

This document, as well as the data, specifications and other information set forth in it, are the exclusive property of Bosch Rexroth AG. It may not be reproduced or given to third parties without its consent.

Liability The specified data is intended for product description purposes only and shall not be deemed to be a guaranteed characteristic unless expressly stipulated in the contract. All rights are reserved with respect to the content of this documentation and the availability of the product.

Published by Bosch Rexroth AG
Bgm.-Dr.-Nebel-Str. 2 ■ 97816 Lohr a. Main, Germany
Phone +49 9352 18 0 ■ Fax +49 9352 18 8400
<http://www.boschrexroth.com/>
DC-IA/EDH1 (DH); DC-IA/EDY1 (RB/US/BB)

Table of Contents

	Page
1 System Presentation.....	11
1.1 System Platform.....	11
1.2 Drive System Rexroth IndraDrive C - Compact Converters.....	12
1.3 Drive System Rexroth IndraDrive M - Modular System.....	14
1.4 Drive System Rexroth IndraDrive Mi.....	17
1.4.1 Drive Systems with KCU01.....	17
1.4.2 Drive Systems with KCU02.....	20
1.5 Combinations of Rexroth IndraDrive C with Rexroth IndraDrive M and Rexroth IndraDrive Mi.....	24
1.6 Basic Design of the Devices.....	24
1.6.1 General Information.....	24
1.6.2 Power Section.....	24
1.6.3 Control Section.....	25
1.7 Overview of Type Currents and Type Performances.....	26
1.7.1 General Information.....	26
1.7.2 Drive Controllers.....	26
1.7.3 Supply Units and Converters.....	27
1.8 Overview of Functions.....	28
1.8.1 Supply Units and Power Sections.....	28
1.8.2 Control Sections.....	28
1.9 Documentations.....	28
1.9.1 About This Documentation.....	28
1.9.2 Overview of Documentations.....	29
Drive Systems, System Components.....	29
Motors.....	30
Cables.....	31
Firmware.....	31
1.9.3 Your Feedback.....	34
2 Important Directions for Use	35
2.1 Appropriate Use	35
2.1.1 Introduction.....	35
2.1.2 Areas of Use and Application.....	35
2.2 Inappropriate Use.....	36
3 Safety Instructions for Electric Drives and Controls.....	37
3.1 Definitions of Terms.....	37
3.2 General Information.....	38
3.2.1 Using the Safety Instructions and Passing Them on to Others.....	38
3.2.2 Requirements for Safe Use.....	38
3.2.3 Hazards by Improper Use.....	39
3.3 Instructions with Regard to Specific Dangers.....	40
3.3.1 Protection Against Contact with Electrical Parts and Housings.....	40
3.3.2 Protective Extra-Low Voltage as Protection Against Electric Shock	41

Table of Contents

	Page
3.3.3	Protection Against Dangerous Movements..... 42
3.3.4	Protection Against Magnetic and Electromagnetic Fields During Operation and Mounting..... 43
3.3.5	Protection Against Contact with Hot Parts..... 44
3.3.6	Protection During Handling and Mounting..... 44
3.3.7	Battery Safety..... 44
3.3.8	Protection Against Pressurized Systems..... 45
3.4	Explanation of Signal Words and the Safety Alert Symbol..... 45
4	Brief Description, Usage..... 47
4.1	General Information..... 47
4.2	Applications of the Drive System Rexroth IndraDrive..... 47
4.3	Mains Transformers DST and DLT..... 47
4.4	Mains Filters HNF, HNK, NFE, HNS02 and NFD..... 47
4.5	Mains Chokes HNL01 and HNL02..... 48
4.6	Supply Units HMV01 / HMV02..... 49
4.7	Drive Controllers HMS01, HMS02 and HMD01..... 49
4.8	Control Sections CSB, CSE, CSH, CDB..... 49
4.9	Drive Controllers HCS02..... 50
4.10	Drive Controllers HCS03..... 50
4.11	Components KCU, KSM, KMS..... 50
4.12	DC Bus Resistor Unit HLB01..... 51
4.13	Braking Resistor HLR01..... 51
4.14	DC Bus Capacitor Unit HLC01..... 52
4.15	Fan Unit HAB01..... 52
4.16	Motor Filters HMF01..... 52
4.17	Accessories HAS..... 52
4.18	Housing for Control Sections HAC01..... 52
4.19	Hall Sensor Box SHL..... 52
5	General Data and Specifications..... 55
5.1	Acceptance Tests and Approvals..... 55
5.2	Transport and Storage..... 57
5.2.1	Transport of the Components..... 57
5.2.2	Storage of the Components..... 58
5.3	Installation Conditions..... 58
5.3.1	Ambient and Operating Conditions..... 58
5.3.2	Mounting Position..... 62
	Mounting Positions of Components..... 62
	Mounting Positions of Motor-Integrated Servo Drives..... 63
5.3.3	Compatibility With Foreign Matters..... 63
5.3.4	Motor Paint Coat..... 64
5.4	Voltage Test and Insulation Resistance Test..... 64
5.5	Control Voltage (24V Supply) 65

Table of Contents

	Page
6	Project Planning of Control Voltage (24V Supply)..... 67
6.1	General Information..... 67
6.2	Selecting the 24V Supply..... 67
6.2.1	General Information..... 67
6.2.2	Electrical Requirements..... 68
6.3	Installing the 24V Supply..... 70
6.4	Looping Through the Control Voltage Supply..... 71
7	Project Planning of Mains Connection 73
7.1	General Information..... 73
7.2	Mains Voltage Supply 73
7.3	Mains Types..... 76
7.3.1	TN-S Mains Type..... 76
7.3.2	TN-C Mains Type..... 76
7.3.3	IT Mains Type..... 77
7.3.4	TT System..... 78
7.3.5	Mains Grounded via Outer Conductor (Corner-Grounded Delta Mains)..... 79
7.4	Mains Short-Circuit Power and Mains Connected Load 79
7.4.1	General Information..... 79
7.4.2	Mains Short-Circuit Power..... 80
7.4.3	Mains Connected Load..... 81
7.5	Protection Systems at the Mains Connection..... 84
7.5.1	General Information..... 84
7.5.2	Protective Grounding..... 85
	General Information..... 85
	Fusing by Protective Grounding in TN-S Mains..... 86
	Fusing by Protective Grounding in TN-C Mains..... 87
	Fusing by Protective Grounding in IT Mains (Ungrounded Mains)..... 88
7.5.3	Connection for the Equipment Grounding Conductor..... 89
	General Information..... 89
	Equipment Grounding Connection Between the Components..... 89
	Connecting Equipment Grounding Conductor to Mains..... 89
7.5.4	Residual-Current-Operated Circuit Breakers (RCD, RCCB) as Additional Fusing..... 89
	General Information..... 89
	Cause of Leakage Currents..... 90
	Possibilities of Use..... 90
	Using Residual-Current-Operated Circuit Breakers at HCS Drive Controllers..... 91
	Using Residual-Current-Operated Circuit Breakers at HMV Supply Units..... 92
7.5.5	Insulation Monitoring Devices..... 92
8	Configuring the Drive System..... 93
8.1	General Information..... 93
8.2	Type of Supply for Power Sections..... 93
8.2.1	General Information..... 93
8.2.2	HMV Supply Units for HMS/HMD Power Sections..... 96

Table of Contents

	Page
Central Supply HMV.....	96
Parallel Operation HMV - Group Supply with DC Bus Connection HMV01, HMV02.....	98
8.2.3 Converter HCS as Supply Unit.....	99
General Information.....	99
Central Supply - HCS Supply HCS or HMS/HMD Drive Controllers.....	99
Parallel Operation HCS - Group Supply with DC Bus Connection of the Groups.....	102
8.2.4 Third-Party Supply Units.....	105
General Information.....	105
8.3 Mains Connection Supply Units and Converters.....	106
8.3.1 General Information.....	106
8.3.2 Mains Connection of HMV Supply Units.....	109
Mains Connection of HMV Supply Units - Additional Components.....	109
Mains Connection of HMV01.1E Supply Units.....	110
Mains Connection of HMV01.1R Supply Units.....	111
Mains Connection of HMV02.1R Supply Units.....	112
8.3.3 Mains Connection for HCS Converters.....	113
Mains Connection for HCS Converters - Additional Components.....	113
Mains Connection for HCS02 Converters.....	114
Mains Connection for HCS03 Converters.....	116
8.4 Additional Components.....	120
8.4.1 Additional Components at the DC Bus.....	120
General Information.....	120
HLR Braking Resistors and DC Bus Resistor Units HLB.....	122
8.4.2 Additional Components at the Motor Output.....	125
General Information.....	125
HMF01 Motor Filters.....	126
8.5 Power Section, Control Section, Firmware	126
8.5.1 General Information.....	126
8.5.2 Power Section - Control Section.....	127
8.5.3 Control Section - Firmware	127
8.5.4 Power Section - Firmware.....	128
8.5.5 Motor - Firmware	133
8.5.6 Encoder System - Encoder Evaluation.....	133
8.6 Combination With Other Rexroth Components.....	136
8.6.1 Combination With Components of the Control Range Rexroth IndraControl V.....	136
Operator Terminals VCP.....	136
8.6.2 sercos Analog Converter.....	136
General Information.....	136
sercos Analog Converter.....	136
8.7 Connection Cables to Motor.....	137
8.7.1 General Information.....	137
8.7.2 Motor cable.....	137
General Information.....	137
Motor Cable Selection	138
Allowed Length of Motor Cable.....	138
Voltage Drop on Connection to Motor Holding Brake.....	139

Table of Contents

	Page
Mechanical Requirements.....	139
Third-Party Power Cables.....	139
8.7.3 Encoder Cables	140
8.8 Using Rexroth IndraDyn Motors.....	140
8.8.1 Rexroth IndraDyn H – Synchronous Kit Spindle Motors.....	140
9 Circuits for the Mains Connection.....	141
9.1 General Information.....	141
9.2 Mains Contactor, Bb Contact.....	141
9.3 Circuits for Mains Connection of Rexroth IndraDrive C Drive Controllers.....	145
9.3.1 General Information.....	145
9.3.2 Control of External Mains Contactor for HCS02 and HCS03.....	145
General Information.....	145
Standard Design for HCS02 and HCS03 Drive Controllers.....	146
Design for HCS02 and HCS03 Drive Controllers with Integrated 24V Control Voltage Supply. .	147
9.3.3 Circuits HCS02 and HCS03 with DC Bus Resistor Unit HLB01.1C or HLB01.1D.....	148
9.4 Circuits for Mains Connection of Rexroth IndraDrive M Supply Units.....	154
9.4.1 General Information.....	154
9.4.2 Parallel Operation HMV01.....	155
9.4.3 Deceleration in the Case of Disturbed Electronic System of Drive (DC Bus Short Circuit is Activated)	155
General Information.....	155
Control Circuits With DC Bus Short Circuit (ZKS).....	157
9.4.4 Deceleration in the Case of Emergency Stop or Mains Failure.....	166
General Information.....	166
Control Circuit "Position-Controlled Deceleration by the Control Unit" without DC Bus Short Circuit (ZKS).....	167
Control Circuit Emergency Stop Relay without DC Bus Short Circuit (ZKS)	169
9.4.5 Signal Sequences When Switching HMV Supply Units ON and OFF.....	177
Switching On.....	177
Switching Off.....	179
10 Electromagnetic Compatibility (EMC).....	181
10.1 EMC Requirements.....	181
10.1.1 General Information.....	181
10.1.2 Noise Immunity in the Drive System.....	181
Basic Structure for Noise Immunity.....	181
Limit Values for Noise Immunity.....	182
10.1.3 Noise Emission of the Drive System.....	182
Causes of Noise Emission.....	182
Limit Values for Line-Based Disturbances.....	183
10.2 Ensuring the EMC Requirements.....	186
10.3 Measures to Reduce Noise Emission.....	187
10.3.1 General Information.....	187
10.3.2 Shielding.....	187
10.3.3 Grounding.....	187

Table of Contents

	Page
10.3.4	Filtering..... 187
11	Arranging the Components in the Control Cabinet 189
11.1	Dimensions and Distances..... 189
11.1.1	Main Dimensions of the System Components..... 189
	General Information..... 189
	Device Depths and Device Heights..... 189
11.1.2	Distances..... 190
	General Information..... 190
	Distance Between the Devices..... 190
	Distance to the Bottom of the Devices..... 191
	Distance to the Top of the Devices..... 191
	Lateral Distance at Drive System..... 193
11.1.3	Boring Dimensions for the Mounting Plate..... 194
	Individually Arranged Devices..... 194
	Combination of Devices of the Rexroth IndraDrive M Product Range..... 196
	Combination of Drive Controllers of the Rexroth IndraDrive C Product Range..... 199
	Combination of Drive Controllers of the Rexroth IndraDrive C and M Product Ranges..... 200
11.2	Arranging Components From Electrical Point of View..... 201
11.2.1	General Information..... 201
11.2.2	Performance-Dependent Arrangement 202
11.2.3	EMC Measures for Design and Installation..... 203
	Rules for Design of Installations With Drive Controllers in Compliance With EMC..... 203
	EMC-Optimal Installation in Facility and Control Cabinet..... 204
	Ground Connections..... 211
	Installing Signal Lines and Signal Cables..... 212
	General Measures of Radio Interference Suppression for Relays, Contactors, Switches, Chokes and Inductive Loads..... 212
12	Project Planning of Cooling System..... 215
12.1	Control Cabinet..... 215
12.1.1	Control Cabinet Design and Cooling..... 215
12.1.2	Arranging the Cooling Units..... 216
12.1.3	Multiple-Line Design of the Control Cabinet..... 218
13	Connections of the Components in the Drive System..... 221
13.1	System Connections of the Components..... 221
13.1.1	General Information..... 221
13.1.2	Position of System Connections..... 222
13.1.3	Ground Connection of Housing..... 222
13.1.4	Connection Point of Equipment Grounding Conductor and Equipment Grounding Connections... 223
	General Information..... 223
	Equipment Grounding Connections Between Devices..... 224
	Connection to Equipment Grounding System in Control Cabinet..... 225
13.1.5	Connection to Mains Choke and Mains Filter 226

Table of Contents

	Page
13.1.6	Connection of the DC Bus Connections..... 228
	General Information..... 228
	Minimum Requirements to Connection Lines..... 229
	Maximum Allowed Line Length at DC Bus Connection..... 230
	Cable Routing to the Left..... 231
	Cable Routing to the Right..... 231
13.1.7	Connection of the Control Voltage Connections..... 232
	General Information..... 232
	Cable Routing to the Left..... 234
	Cable Routing to the Right..... 235
13.1.8	Module Bus Connection X1..... 235
13.1.9	Connection of Motor to Drive Controller..... 236
	General Information..... 236
	Shield Connection with Accessory HAS02..... 237
	Shield Connection without Accessory HAS02..... 237
13.2	Overall Connection Diagrams of Drive Systems..... 240
14	Third-Party Motors at Rexroth IndraDrive Controllers..... 241
14.1	General Information on Third-Party Motors..... 241
14.1.1	Why Use Third-Party Motors at Rexroth IndraDrive Controllers?..... 241
14.1.2	Which are the Important Directives?..... 241
14.1.3	Third-Party Motors to be Controlled..... 241
14.2	Requirements on Third-Party Motors..... 242
14.2.1	General Information..... 242
14.2.2	Voltage Load of the Third-Party Motor 242
14.2.3	Minimum Inductance of Third-Party Motor..... 243
14.2.4	Temperature Evaluation of Third-Party Motor..... 244
14.3	Requirements on the Encoder of the Third-Party Motor..... 245
14.3.1	Motor Encoder of Asynchronous Third-Party Motor..... 245
14.3.2	Motor Encoder of Synchronous Third-Party Motor..... 245
14.3.3	Motor Encoder Resolver - Notes on Selection..... 245
14.4	Notes on Selection and Commissioning..... 245
14.4.1	Selecting the Controller as Regards Continuous Current..... 245
14.4.2	Selecting the Connection Technique..... 246
14.4.3	Notes on Commissioning..... 246
15	Calculations..... 247
15.1	Determining the Appropriate Drive Controller..... 247
15.1.1	Introduction..... 247
15.1.2	DC Bus Continuous Power..... 247
15.1.3	DC Bus Peak Power..... 251
15.1.4	Regenerative Power..... 251
15.1.5	Reduction of Generated Power Dissipation - Additional External Capacitors at DC Bus..... 252
15.1.6	Continuous Regenerative Power..... 255
15.1.7	Peak Regenerative Power..... 257

Table of Contents

	Page
15.1.8	Calculating the Control Factor..... 258
15.2	Calculations for the Mains Connection..... 260
15.2.1	Calculating the Mains-Side Phase Current 260
15.2.2	Calculating the Inrush Current..... 261
15.2.3	Calculations for the Mains Harmonics..... 261
	Harmonic Load THD..... 261
	Harmonic Content / Distortion Factor k..... 261
	Power Factor $\cos\phi_1$ or DPF for Calculating the Wattless Power Load of the Mains..... 262
	Power Factor $\cos\phi$ or TPF (λ)..... 262
15.2.4	Mains Voltage Unbalance..... 262
15.2.5	Calculating the Allowed Continuous Power in the Common DC Bus..... 263
15.3	Determining Components in the Mains Connection..... 264
15.3.1	Determining the Mains Choke..... 264
15.3.2	Determining the Mains Filter..... 264
15.3.3	Determining Mains Transformer DLT..... 265
15.3.4	Mains Contactor and Fusing 265
15.3.5	Dimensioning the Line Cross Sections and Fuses 266
15.3.6	Determining the Leakage Capacitance..... 272
15.3.7	Determining the Allowed Operating Data of Mains Filters..... 273
	Reducing Allowed Operating Voltage Depending on Actual Temperature Rise Due to Harmonics 273
	Current Reduction in the Case of Overtemperature..... 274
15.4	Other Calculations..... 276
15.4.1	Charging the DC Bus..... 276
15.4.2	Calculating Speed Characteristic and Braking Time With DC Bus Short Circuit (ZKS)..... 277
16	Environmental Protection and Disposal 281
16.1	Environmental Protection..... 281
16.2	Disposal..... 281
17	Service and Support..... 283
18	Appendix..... 285
18.1	System Elements - Product Overview, Short Designations..... 285
18.2	Leakage Capacitances..... 287
18.2.1	Leakage Capacitance of Motors..... 287
18.2.2	Leakage Capacitance of Power Cables 288
18.3	Emitted Harmonics on Mains Current and Mains Voltage..... 290
18.3.1	General Information..... 290
18.3.2	Harmonics of Mains Current..... 290
18.3.3	Harmonics on Mains Voltage..... 294
18.4	Voltage Pulse for Test According to EN61000..... 294
18.5	Discharging of Capacitors..... 296
18.5.1	Discharging DC Bus Capacitors..... 296

Table of Contents

	Page
Glossary, Definitions of Terms, Abbreviations	297
Index.....	301

1 System Presentation

1.1 System Platform

The following products are part of the **Rexroth IndraDrive** system platform:

Platform Rexroth IndraDrive								
Control sections			Power sections		Supply units		Additional components	Motor-integrated / near motor drive technology
Economy C*E Single-axis	Basic C*B Single-axis/ double-axis	Advanced C*H Single-axis	Modular HM* Single-axis/ double-axis	Compact HC* Single-axis	HMV-E	HMV-R	HNF HNL HLB HLC HLR	KCU KSM KMS

Tab. 1-1: Rexroth IndraDrive System Platform

Hierarchical Levels of Rexroth IndraDrive

The assignment of the fundamental components to the hierarchical levels system platform, type, range, series and component is illustrated in the figure below.

Platform	Rexroth IndraDrive									
Type	Rexroth IndraDrive power sections							Rexroth IndraDrive control sections		
Range	Rexroth IndraDrive C				Rexroth IndraDrive M			Economy	Basic	Advanced
Series	HCS01	HCS02	HCS03	HCS04	HMV01 HMV02	HMS01 HMS02	HMD01	CSE	CSB CDB	CSH
Component	W0003... W0054	W0012... W0070	W0070... W0210	W0350... W1540	W0015... W0120	W0020... W0350	W0012... W0036	02	01 02	01 02

Tab. 1-2: Hierarchical Levels Rexroth IndraDrive C and M

Platform	Rexroth IndraDrive			
Type	Rexroth IndraDrive motor-integrated servo drives	Rexroth IndraDrive near motor servo drives	Rexroth IndraDrive, drive connection box	Rexroth cables
Range	Rexroth IndraDrive Mi			Hybrid cable
Series	KSM01, KSM02	KMS01, KMS02	KCU01, KCU02	RKHxxxx
Component	Different sizes, lengths and designs	KMS01.2B-A018 KMS02.1B-A018	KCU01.2N-SE-SE*-025-NN-S KCU02.1N-ET-ET*-025-NN-N	Different lengths and codings

Tab. 1-3: Hierarchical Levels Rexroth IndraDrive Mi

Short Designations

For an overview of the short designations, such as HMV, HCS, CSH, KCU, etc., see Appendix of this documentation, chapter [18.1 System Elements - Product Overview, Short Designations, page 285](#).

System Presentation

1.2 Drive System Rexroth IndraDrive C - Compact Converters

Rexroth IndraDrive C is the compact converter type of the Rexroth IndraDrive product range.

Basic features of the product range Rexroth IndraDrive C:

- Integrated power supply
- Integrated braking resistor (as an option, external for HCS03)
- Integrated inverters
- Integrated 24V control voltage supply (optional for HCS02)
- Additional components:
 - DC bus resistor units
 - DC bus capacitor units
 - Braking resistors

The figure below illustrates the system structure of the drive system Rexroth IndraDrive C. Allowed combinations of components: See [chapter 8 "Configuring the Drive System"](#) on page 93

System Presentation

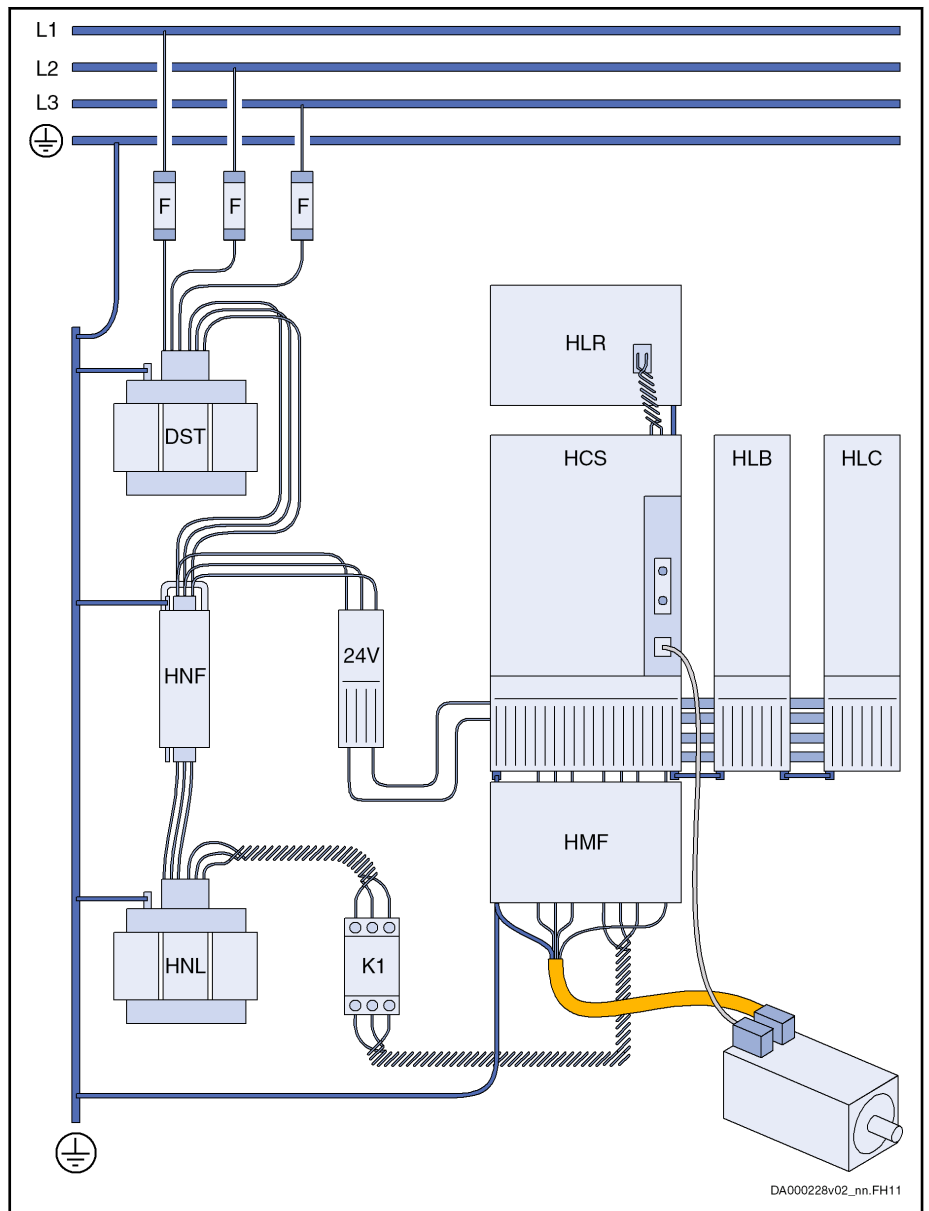

Fig. 1-1: Drive System Rexroth IndraDrive C



When using an HNK mains filter at HCS03 devices, connect the mains contactor between mains supply and mains filter.

System Presentation

1.3 Drive System Rexroth IndraDrive M - Modular System

Rexroth IndraDrive M is the modular system type of the Rexroth IndraDrive product range.

The combination of an HMV supply unit and HMS and HMD drive controllers to form a modular drive system allows operating several motors.

Basic features of the product range Rexroth IndraDrive M:

- Scalable power supply
- Integrated mains contactor (except for HMV01.1R-W0120)
- Modular extension of number of axes is possible
- Two series (mounting depths) of HMV and HMS available
- Additional components:
 - DC bus resistor units
 - DC bus capacitor units

The figure below illustrates the system structure of the drive system Rexroth IndraDrive M. Allowed combinations of components: See [chapter 8 "Configuring the Drive System" on page 93](#)

System Presentation

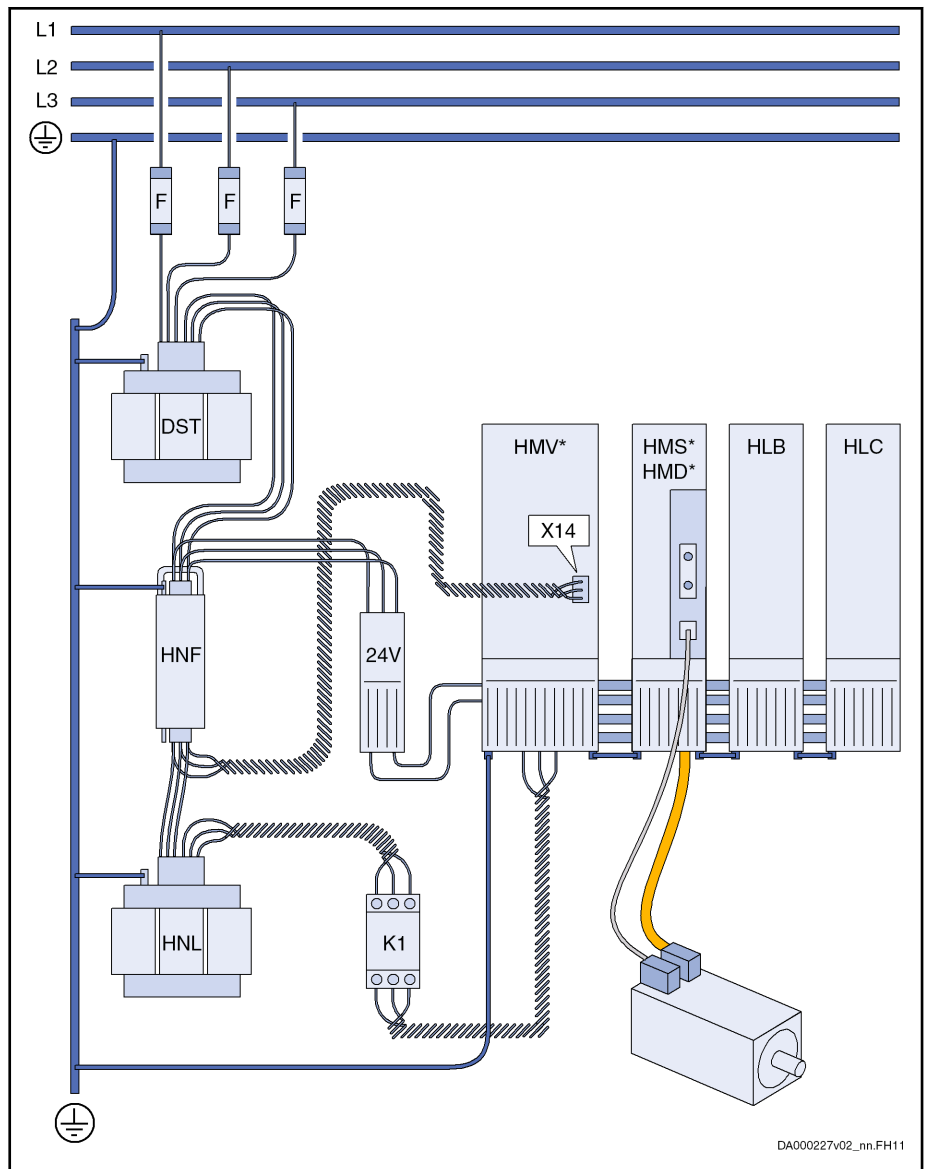

DA000227v02_nrn.FH11

- HMV* HMV01.1E-W...; HMV01.1R-W...
 - HMS*; HMD* HMS01.1N-W...; HMD01.1N-W...
 - K1 External mains contactor K1 required only for HMV01.1R-W0120
 - HNL Optional mains choke (HNL) for HMV01.1E, required for HMV01.1R
 - HNF Optional mains filter (HNF); depends on EMC requirements
- Fig. 1-2: Drive System Rexroth IndraDrive M (Series 01)

System Presentation

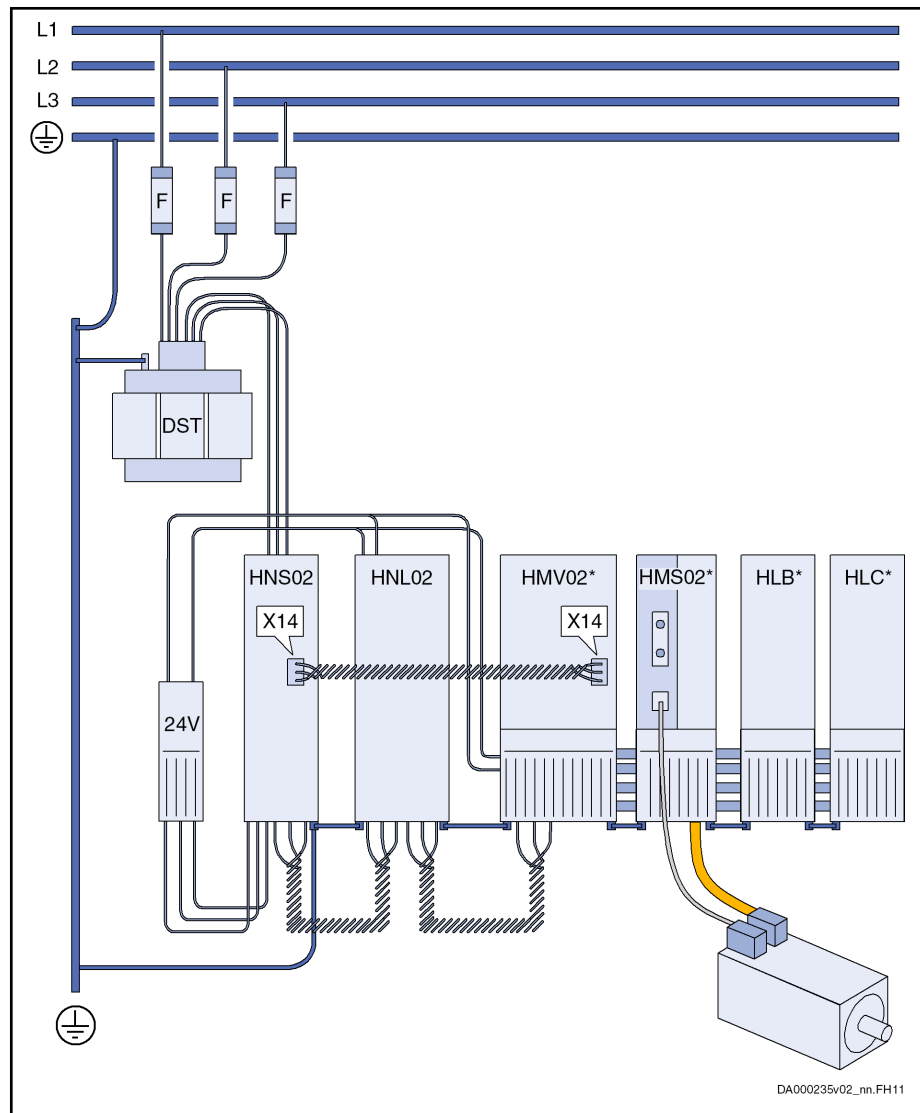

HMV02* HMV02.1R-W...
 HMS02* HMS02.1N-W...
 HLB* HLB01.1C (optional)
 HLC* HLC01.1C (optional)

Fig. 1-3: Drive System Rexroth IndraDrive M (Series 02)

1.4 Drive System Rexroth IndraDrive Mi

1.4.1 Drive Systems with KCU01

The figure below illustrates the system structure of the drive system Rexroth IndraDrive Mi with HMV supply unit. Allowed combinations of components: See [chapter 8 "Configuring the Drive System"](#) on page 93

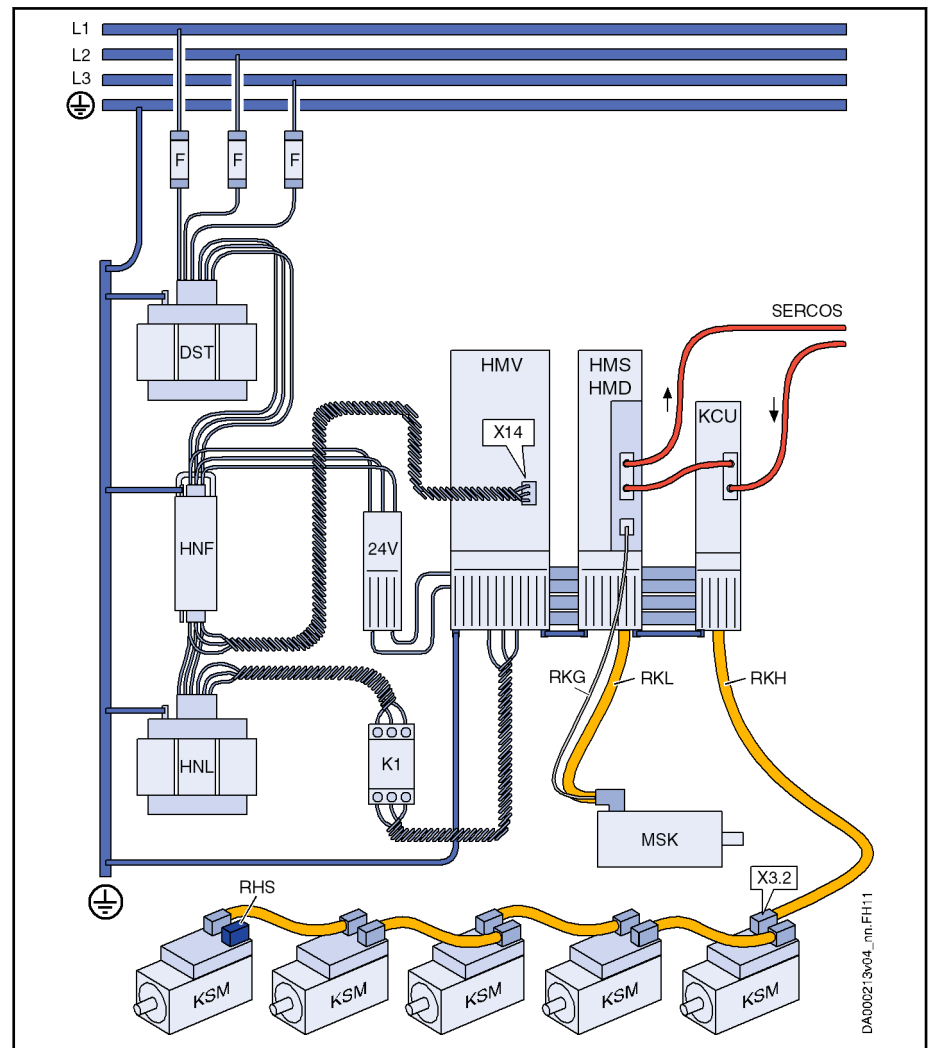

External mains contactor K1 required only for HMV01.1R-W0120

Fig. 1-4: System Structure Rexroth IndraDrive Mi with HMV

The figure below illustrates the system structure of the drive system Rexroth IndraDrive Mi supplied by an HCS converter. Allowed combinations of components: See [chapter 8 "Configuring the Drive System"](#) on page 93

System Presentation

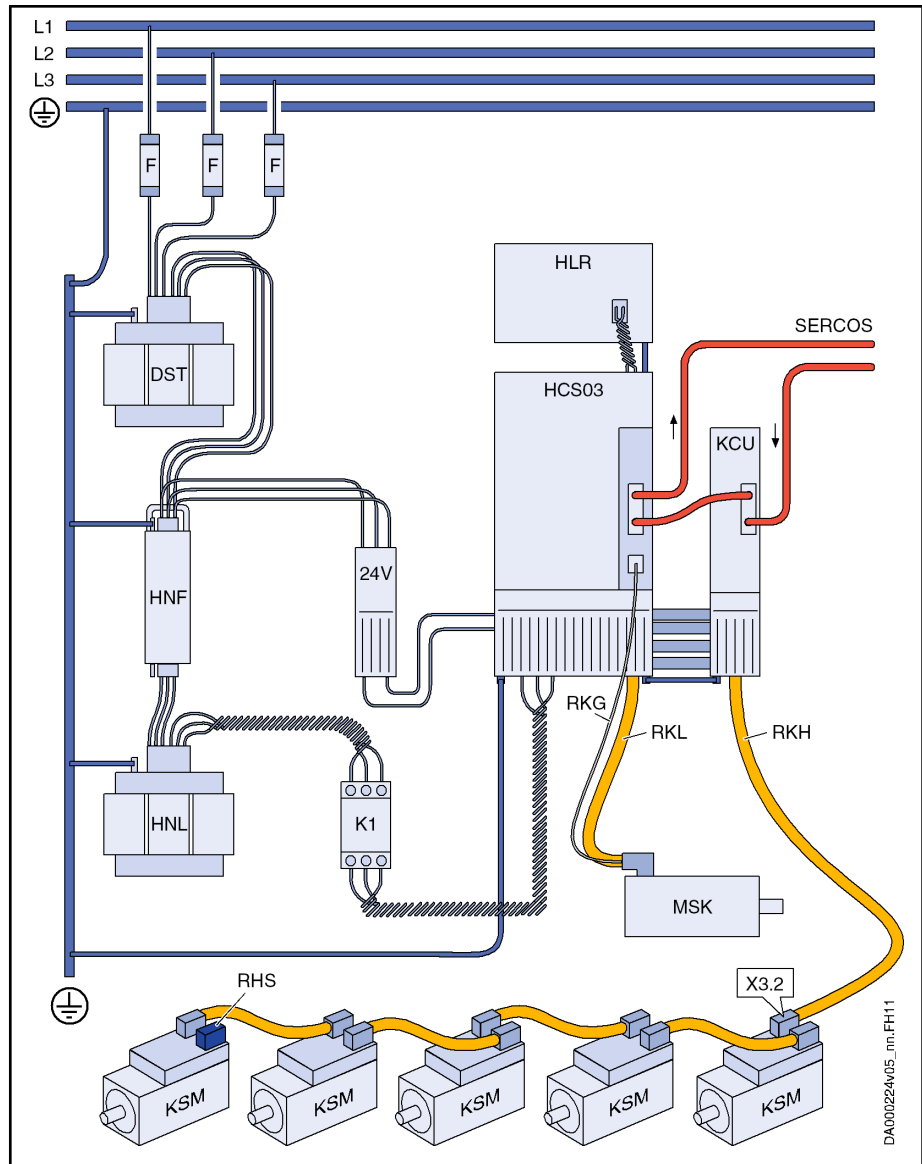

Fig.1-5: System Structure Rexroth IndraDrive Mi with HCS03

DA000224/05_mn_FH11

System Presentation

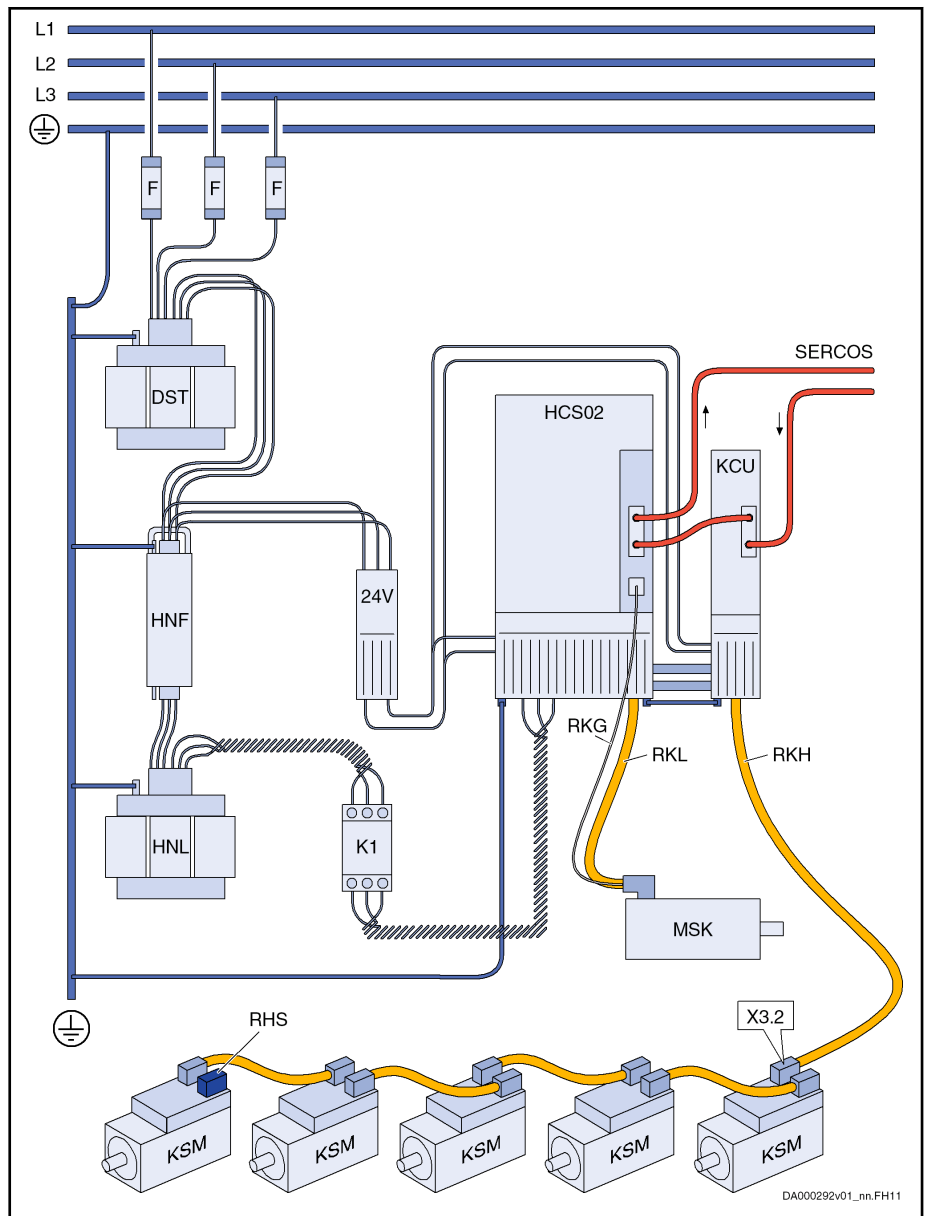
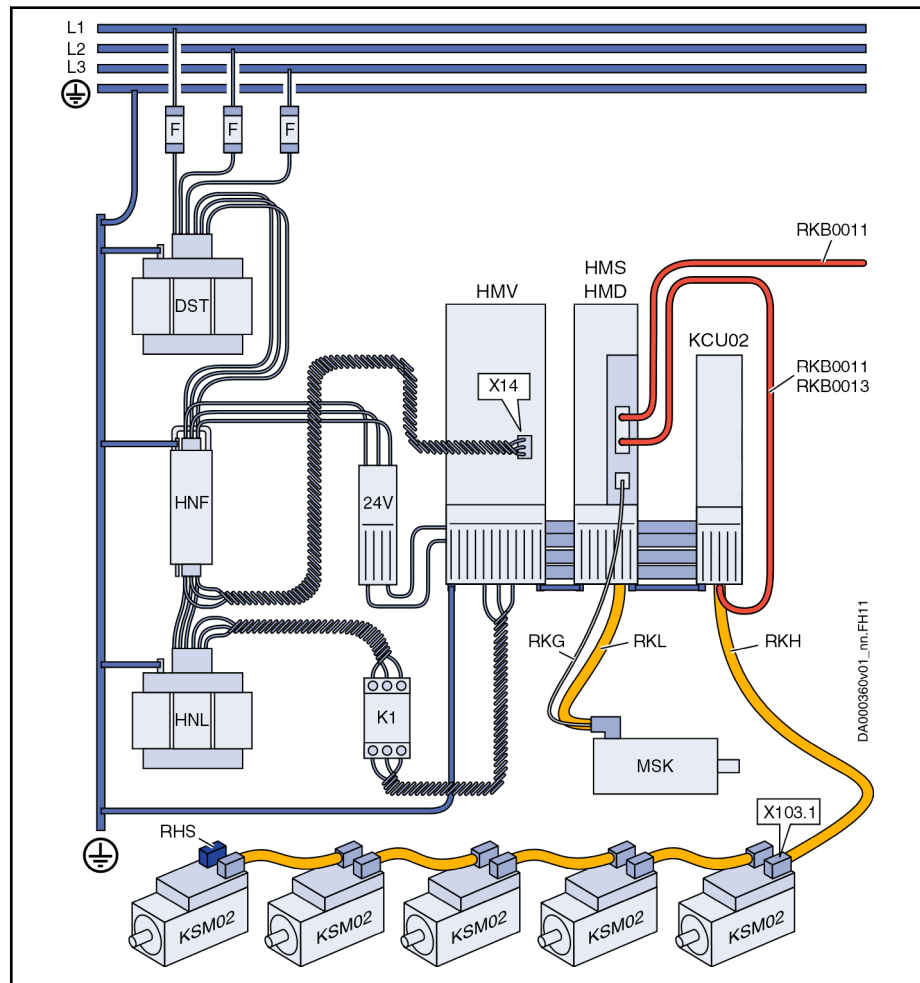

Fig. 1-6: System Structure Rexroth IndraDrive Mi with HCS02

System Presentation

1.4.2 Drive Systems with KCU02

Drive System Rexroth IndraDrive with HMV01 Supply Unit:



24V	24V supply
DST	Transformer (optional)
F	Fuses
HMD, HMS	Inverter (optional)
HMV01	Supply unit
HNF	Mains filter
HNL	Mains choke
K1	Mains contactor (only for supply units without integrated mains contactor, e.g. HMV01.1R-W0120)
KCU	Drive connection box
KSM	Motor-integrated servo drive
MSK	Servo motor (optional)
RHS	Terminal connector
RKB	Communication cable
RKG	Encoder cable (optional)
RKH	Hybrid cable
RKL	Motor cable (optional)
X14	Mains synchronization (only with regenerative HMVs)
X103.1	Connection of hybrid cable RKH at first KSM
Fig. 1-7:	Drive System Rexroth IndraDrive with HMV01

System Presentation

Drive System Rexroth IndraDrive with HCS02 Supply Unit:

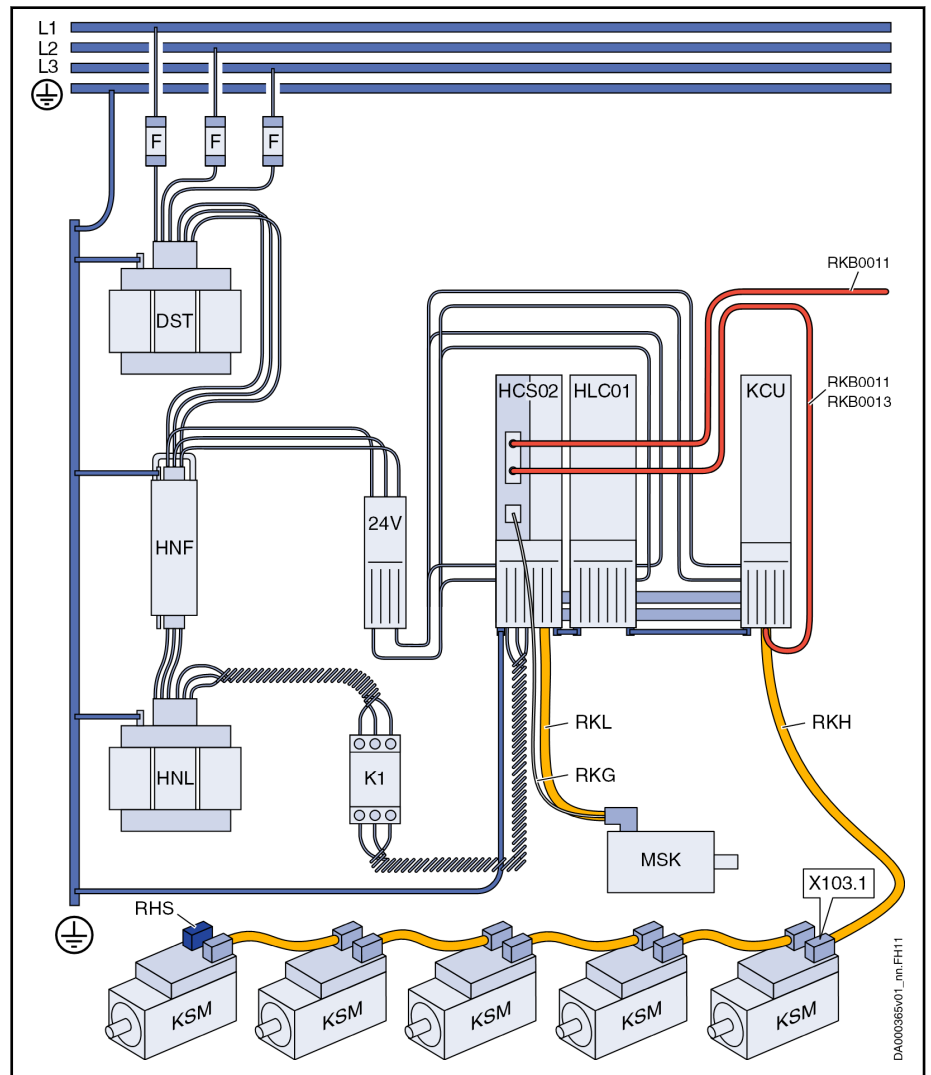

- DST Transformer (optional)
 - F Fuses
 - HCS02 Converter (HCS02.1E-W0054 or HCS02.1E-W0070)
 - HNF Mains filter
 - HNL Mains choke (optional)
 - HLC01 DC bus capacitor unit (optional only with low load of motor output at HCS02)
 - K1 Mains contactor
 - KCU Drive connection box
 - KSM Motor-integrated servo drive
 - MSK Servo motor
 - 24V 24V supply
 - RHS Terminal connector
 - RKB Communication cable
 - RKG Encoder cable
 - RKH Hybrid cable
 - RKL Motor cable
 - X103.1 Connection of hybrid cable at first KSM
- Fig. 1-8: Drive System Rexroth IndraDrive with HCS02

System Presentation

Drive System Rexroth IndraDrive with HCS03 Supply Unit:

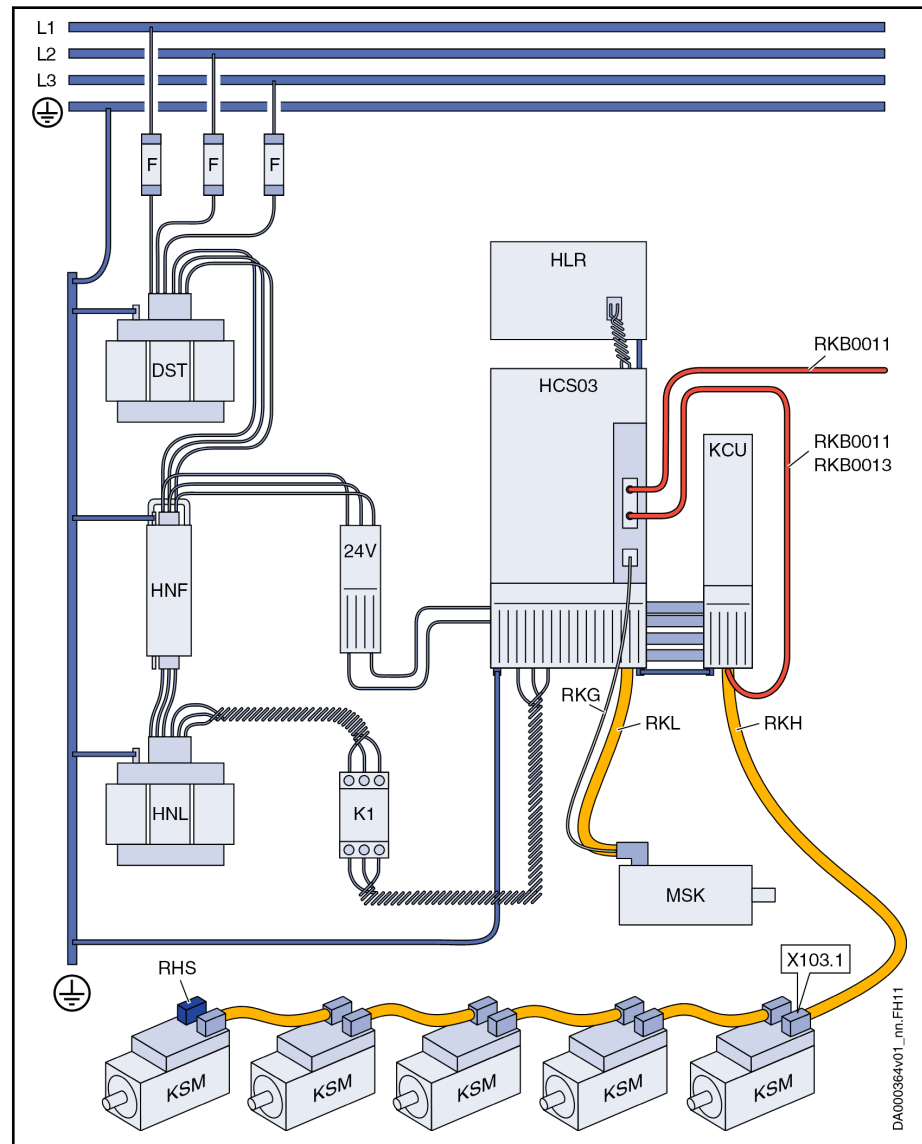

DST	Transformer (optional)
F	Fuses
HCS03	Converter
HLR	Braking resistor (optional)
HNF	Mains filter
HNL	Mains choke (optional)
K1	Mains contactor
KCU	Drive connection box
KSM	Motor-integrated servo drive
MSK	Servo motor
RHS	Terminal connector
RKB	Communication cable
RKH	Hybrid cable
RKG	Encoder cable
RKL	Motor cable
24V	24V supply
X103.1	Connection of hybrid cable at first KSM

Fig. 1-9: Drive System Rexroth IndraDrive with HCS03

System Presentation

Drive System Rexroth IndraDrive with HMV02 Supply Unit:

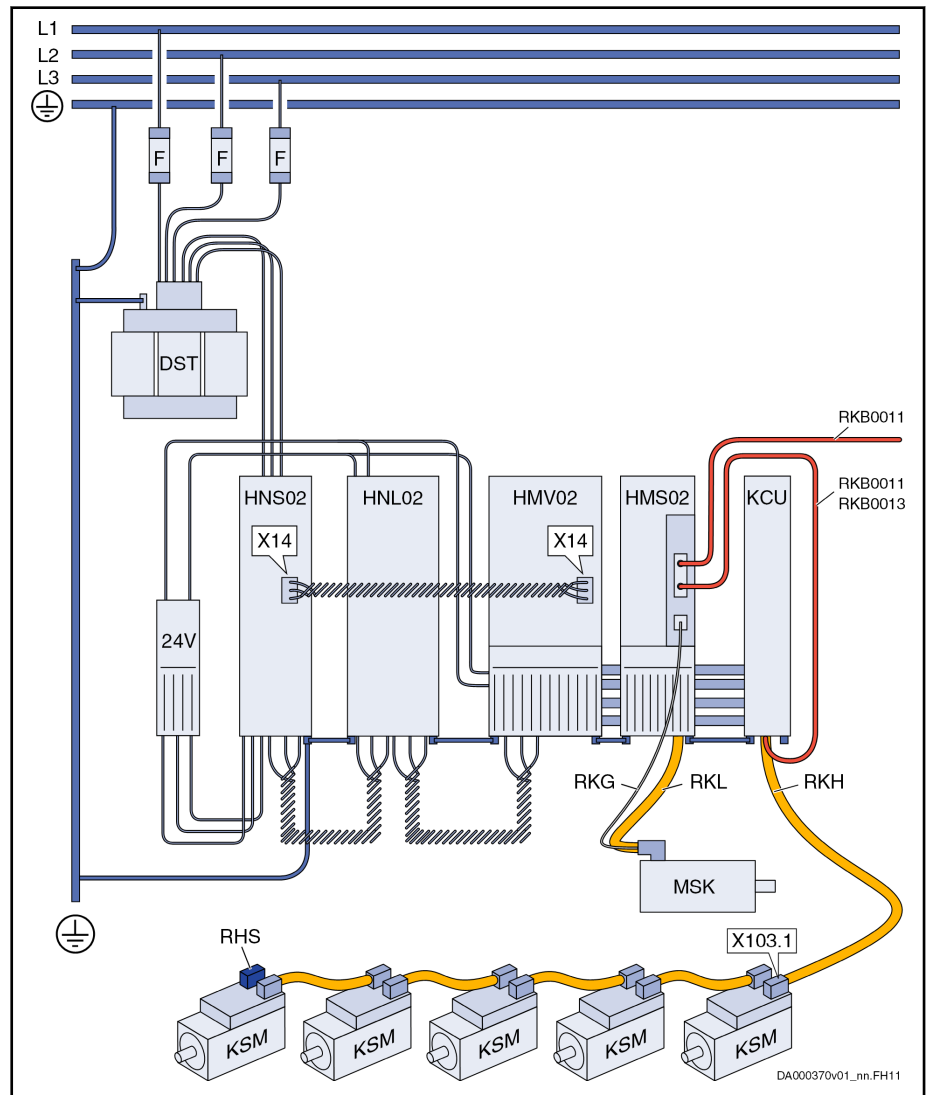

- 24V 24V supply
 - DST Transformer (optional)
 - F Fuses
 - HMS02 Inverter (optional)
 - HMV02 Supply unit
 - HNS02 Mains filter with switch-disconnector
 - HNL02 Mains choke
 - KCU Drive connection box
 - KSM Motor-integrated servo drive
 - MSK Servo motor (optional)
 - RHS Terminal connector
 - RKB Communication cable
 - RKG Encoder cable (optional)
 - RKH Hybrid cable
 - RKL Motor cable (optional)
 - X14 Mains synchronization (only with regenerative HMVs)
 - X103.1 Connection of hybrid cable RKH at first KSM
- Fig. 1-10: Drive System Rexroth IndraDrive with HMV02

DA000370v01_nn.FH11

System Presentation

1.5 Combinations of Rexroth IndraDrive C with Rexroth IndraDrive M and Rexroth IndraDrive Mi

On the common Rexroth IndraDrive platform, it is possible to combine the components of the product ranges Rexroth IndraDrive C, Rexroth IndraDrive M and Rexroth IndraDrive Mi to form drive systems of optimum costs and performance.

To supply the components of the product range Rexroth IndraDrive Mi (KCU with KSM/KMS), you can use:

- Modular HMV01 and HMV02 supply units
- HCS02 and HCS03 converters

Allowed combinations of components: See [chapter 8 "Configuring the Drive System" on page 93](#)

1.6 Basic Design of the Devices

1.6.1 General Information

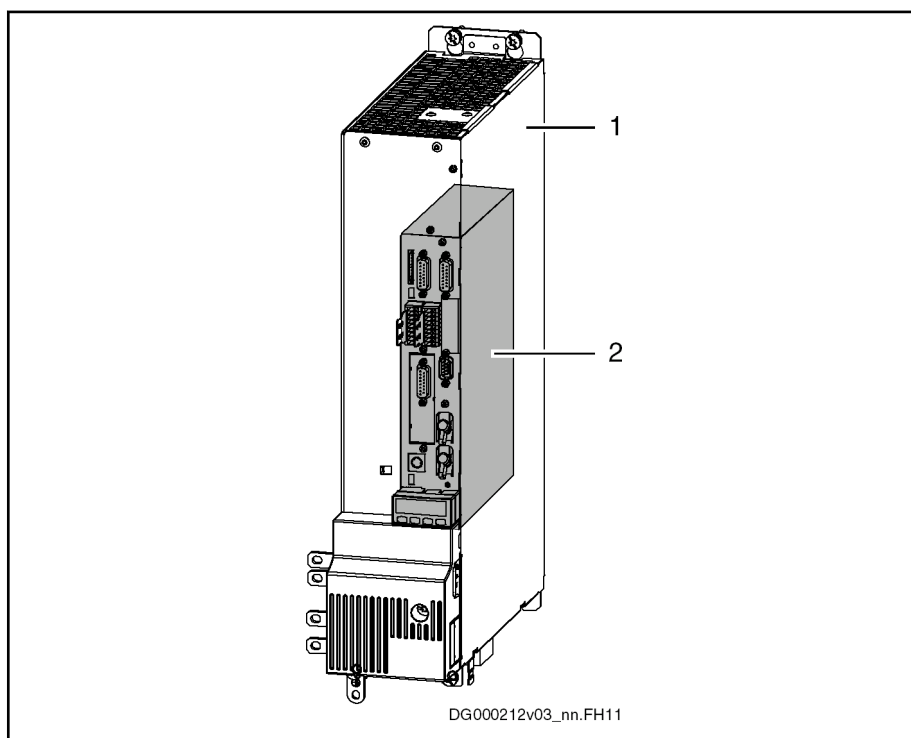

- 1 Power section
2 Control section

Fig. 1-11: Basic Design of a Drive Controller

A drive controller consists of two essential parts:

- Power section
- Control section

1.6.2 Power Section

The power section incorporates the control section and has the following connections:

- Mains voltage connection (at HCS devices)

- Motor connection (with optional motor holding brake and motor temperature monitor)
- 24 V control voltage
- DC bus connection
- Module bus connection for cross communication in the case of DC bus connection with other devices
- Connection for external braking resistor (at HCS devices)

 For detailed information on the power sections, see Project Planning Manual "Rexroth IndraDrive Supply Units and Power Sections".

1.6.3 Control Section

The control section is a separate component which is plugged into the power section. The control section consists of:

- Basic control section circuit board with interfaces
- Optional modules (only for configurable control sections)

The drive controller is supplied complete with factory-installed (possibly configured) control section.



Only especially trained staff are allowed to replace control sections.

 For detailed information on the control sections, see Project Planning Manual "Rexroth IndraDrive Drive Controllers Control Sections".

System Presentation

1.7 Overview of Type Currents and Type Performances

1.7.1 General Information

To allow you selecting appropriate drive controllers for a multitude of applications, the Rexroth IndraDrive product range includes a wide range of type currents and performances. The table below shows the fundamental data of drive controllers and supply units.

 For detailed technical data, see Project Planning Manual "Rexroth IndraDrive Supply Units and Power Sections".

1.7.2 Drive Controllers

The order of the following table lines conforms with the peak currents of the devices.

Compact converters	Modular inverters	Type current	Contin. current $I_{out_cont_4k}$ [A] ¹⁾	Peak current $I_{out_max_4k}$ [A] ¹⁾	Nominal motor power [kW] ²⁾
HCS01	-	W0003 ³⁾		3	
HCS01	-	W0005 ⁴⁾		5	
HCS01	-	W0006 ³⁾		6	
HCS01	-	W0008 ⁴⁾		8	
HCS01	-	W0009 ³⁾		9	
HCS02	-	W0012	4	12	1,5
-	HMD01	W0012	6,9	12	-
HCS01	-	W0013 ³⁾		13	
HCS01	-	W0018 ⁴⁾		18	
-	HMS01	W0020	12,1	20	-
-	HMD01	W0020	12,1	20	-
HCS01	-	W0028 ⁴⁾		28	
HCS02	-	W0028	11	28	4,0
-	HMS02	W0028	13	28	-
-	HMS01	W0036	21,3	36	-
-	HMD01	W0036	20	36	-
HCS02	-	W0054	22	54	7,5
-	HMS01	W0054	35	54	-
-	HMS02	W0054	25	54	-
HCS02	-	W0070	28	70	11
HCS03	-	W0070	45	70	18,5
-	HMS01	W0070	42,4	70	-
HCS03	-	W0100	73	100	30
-	HMS01	W0110	68,5	110	-
HCS03	-	W0150	95	150	45

System Presentation

Compact converters	Modular inverters	Type current	Contin. current $I_{out_cont_4k}$ [A] ¹⁾	Peak current $I_{out_max_4k}$ [A] ¹⁾	Nominal motor power [kW] ²⁾
-	HMS01	W0150	100	150	-
HCS03	-	W0210	145	210	75
-	HMS01	W0210	145	210	-
-	HMS01	W0350	250	350	-

1) At $f_s = 4$ kHz; without overload

2) For standard motor 3 AC 400 V; use of mains choke HNL01; variable torque

3) Mains connection voltage 3 AC 110 ... 230 V

4) Mains connection voltage 3 AC 200 ... 500 V

Tab. 1-4: Type Current and Type Performances

1.7.3 Supply Units and Converters

The order of the following table lines conforms with the continuous power of the devices.

Compact converters	Modular mains supply	Type current or performance	Contin. power "ON" P_{DC_cont} [kW] ¹⁾	Peak power "ON" P_{DC_peak} [kW] ¹⁾	Contin. braking power [kW]	Max. braking power [kW]
HCS02	-	E-W0028	4,2	10	0,15	10
HCS02	-	E-W0054	9,1	16	0,35	18
HCS02	-	E-W0070	13,3	19	0,5	25
-	HMV01	R-W0018	18	45	0,4	36
HCS03	-	E-W0070	25	40	opt.	opt.
-	HMV01	E-W0030	30	45	1,5	36
HCS03	-	E-W0100	43	59	opt.	opt.
HCS03	-	E-W0150	56	89	opt.	opt.
-	HMV02	R-W0015	15	37,5	0,3	33
-	HMV01	R-W0045	45	112	0,4	90
-	HMV01	R-W0065	65	162	0,4	130
-	HMV01	E-W0075	75	112	2	90
HCS03	-	E-W0210	85	124	opt.	opt.
-	HMV01	E-W0120	120	180	2,5	130
-	HMV01	R-W0120	120	180	0	0

opt. Equipment to be optionally ordered

1) With use of mains choke HNL01; at 3 AC 400 V

Tab. 1-5: Performance Data of Mains Supply Units

The data of peak power and continuous power show the maximum possible limit values.

 For the actually available performance profiles, see Project Planning Manual "Rexroth IndraDrive Supply Units and Power Sections" → Chapter of the respective component → "Technical Data" → "Exemplary Data for Applications" → "Performance Profiles".

System Presentation

1.8 Overview of Functions

1.8.1 Supply Units and Power Sections

 For an overview of the functions of supply units and power sections, see Project Planning Manual "Rexroth IndraDrive Supply Units and Power Sections" → "Functions and Connection Points" → "Overview of Functions, Power Sections and Supply Units".

1.8.2 Control Sections

 For an overview of the functions of control sections, see Project Planning Manual "Rexroth IndraDrive Drive Controllers Control Sections" → "Rexroth IndraDrive Control Sections" → "Overview of Functions and Interfaces of the Control Sections".

1.9 Documentations

1.9.1 About This Documentation

⚠ WARNING

Personal injury and property damage caused by incorrect project planning for applications, machines and installations!

Observe the contents of the documentations relevant to your drive system.

Purpose of Documentation

This documentation contains

- Overview information of the Rexroth IndraDrive drive system
- Description of the allowed combinations of Rexroth IndraDrive system components
- Selection of the system components of the Rexroth IndraDrive drive system
- Specification applying to all components (ambient and operating conditions)
- Application description of system characteristics

Changes in Comparison to Previous Edition

Chapter	Changes
All chapters	Design of safety instructions modified in accordance with the ANSI Z535.6 standard
System Presentation	Drive systems IndraDrive Mi with KCU02, KSM02 and KMS02 included Overview of documentations updated
Brief Description, Usage	KCU, KSM, KMS components included CSE02, CSB02, CDB02, CSH02 control sections included

System Presentation

Chapter	Changes
General Data and Specifications	Standards updated UL file numbers included Ambient and Operating Conditions: One table each created for Rexroth IndraDrive and Rexroth IndraDrive Mi and data updated Description of mounting positions revised Chapter "Prime Coat and Housing Varnish" renamed as "Motor Varnish" and updated
Project Planning of Mains Connection	IT mains type: HCS03 not allowed Chapter "Protective Grounding": Note on fault loop impedance and disconnecting time of mains circuit breaker included
Configuration of the Drive System	Mains Connection for HCS Converters - Additional Components: Table "C _y , Capacitances against Housing" revised KCU02, KSM02 and KMS02 included Supply units of "FNN2" design (Smart Energy Mode) included
Circuits for the Mains Connection	HMV01.1R with HLB01.1D included
Arranging the Components in the Control Cabinet	Chapter "EMC-Optimal Installation in Facility and Control Cabinet" revised
Project Planning of Cooling System	Contents revised
Environmental Protection and Disposal	Information on batteries and accumulators included
Service and Support	Contents updated
Appendix	Discharging of Capacitors: Discharging device removed

Tab. 1-6: Changes

1.9.2 Overview of Documentations

Drive Systems, System Components

Title Rexroth IndraDrive ...	Kind of documentation	Document typecode ¹⁾ DOK-INDRV*-...	Material number R911...
Drive Systems with HMV01/02 HMS01/02, HMD01, HCS02/03	Project Planning Manual	SYSTEM*****-PRxx-EN-P	309636
Mi Drive Systems with KCU01, KSM01, KMS01	Project Planning Manual	KCU+KSM****-PRxx-EN-P	320924
Mi Drive Systems with KCU02, KSM02, KMS02	Project Planning Manual	KCU02+KSM02-PRxx-EN-P	335703

System Presentation

Title Rexroth IndraDrive ...	Kind of documentation	Document typecode ¹⁾ DOK-INDRV*-...	Material number R911...
Supply Units, Power Sections HMV, HMS, HMD, HCS02, HCS03	Project Planning Manual	HMV-S-D+HCS-PRxx-EN-P	318790
Drive Controllers Control Sections CSB01, CSH01, CDB01	Project Planning Manual	CSH*****-PRxx-EN-P	295012
Control Sections CSE02, CSB02, CDB02, CSH02	Project Planning Manual	Cxx02*****-PRxx-EN-P	338962
Additional Components and Accessories	Project Planning Manual	ADDCOMP****-PRxx-EN-P	306140

1) In the document typecodes, "xx" is a wild card for the current edition of the documentation (example: PR01 is the first edition of a Project Planning Manual)

Tab. 1-7: Documentations – Overview

Title	Kind of documentation	Document typecode ¹⁾	Material number R911...
Automation Terminals Of The Rexroth Inline Product Range	Application Manual	DOK-CONTRL-ILSYSINS***- AWxx-EN-P	317021

1) In the document typecodes, "xx" is a wild card for the current edition of the documentation (example: AW01 is the first edition of an Application Manual)

Tab. 1-8: Documentations – Overview

Motors

Title Rexroth IndraDyn ...	Kind of documentation	Document typecode ¹⁾ DOK-MOTOR*-...	Material number R911...
A Asynchronous Motors MAD / MAF	Project Planning Manual	MAD/MAF****-PRxx-EN-P	295781
H Synchronous Kit Spindle Motors	Project Planning Manual	MBS-H*****-PRxx-EN-P	297895
L Synchronous Linear Motors	Project Planning Manual	MLF*****-PRxx-EN-P	293635
S Synchronous Motors MSK	Project Planning Manual	MSK*****-PRxx-EN-P	296289
T Synchronous Torque Motors	Project Planning Manual	MBT*****-PRxx-EN-P	298798

1) In the document typecodes, "xx" is a wild card for the current edition of the documentation (example: PR01 is the first edition of a Project Planning Manual)

Tab. 1-9: Documentations – Overview

Cables

Title	Kind of documentation	Document typecode ¹⁾ DOK-...	Material number R911...
Rexroth Connection Cables IndraDrive and IndraDyn	Selection Data	CONNEX-CABLE*INDRV-CAxx- EN-P	322949

1) In the document typecodes, "xx" is a wild card for the current edition of the documentation (example: CA02 is the second edition of the documentation "Selection Data")

Tab. 1-10: Documentations – Overview

Firmware

Title Rexroth IndraDrive ...	Kind of documentation	Document typecode ¹⁾ DOK-INDRV*-...	Part number R911...
Firmware for Drive Controllers MPH-08, MPB-08, MPD-08, MPC-08	Functional Description	MP*-08VRS**-APxx-EN-P	332643
Firmware for Drive Controllers MPH-07, MPB-07, MPD-07, MPC-07	Functional Description	MP*-07VRS**-FKxx-EN-P	328670
Firmware for Drive Controllers MPH-06, MPB-06, MPD-06, MPC-06	Functional Description	MP*-06VRS**-FKxx-EN-P	326766
Firmware for Drive Controllers MPH-05, MPB-05, MPD-05	Functional Description	MP*-05VRS**-FKxx-EN-P	320182
Firmware for Drive Controllers MPH-04, MPB-04, MPD-04	Functional Description	MP*-04VRS**-FKxx-EN-P	315485
Firmware for Drive Controllers MPH-03, MPB-03, MPD-03	Functional Description	MP*-03VRS**-FKxx-EN-P	308329
Firmware for Drive Controllers MPH-02, MPB-02, MPD-02	Functional Description	MP*-02VRS**-FKxx-EN-P	299223
Drive Controllers MPx-02 to MPx-08	Parameter Description	GEN-**VRS**-PAxx-EN-P	297317
MPx-02 to MPx-08 and HMV	Troubleshooting Guide	GEN-**VRS**-WAxx-EN-P	297319
Integrated Safety Technology	Functional and Application Description	SI*-**VRS**-FKxx-EN-P	297838
Integrated Safety Technology According to IEC61508	Functional Description	SI2-**VRS**-FKxx-EN-P	327664
Rexroth IndraMotion MLD	Application Manual	MLD-**VRS**-AWxx-EN-P	306084
Rexroth IndraMotion MLD Library	Library Description	MLD-SYSLIB*-FKxx-EN-P	309224

1) In the document typecodes, "xx" is a wild card for the current edition of the documentation (example: FK02 is the second edition of a Functional Description)

Tab. 1-11: Documentations – Overview

System Presentation

Title	Kind of documentation	Document typecode ¹⁾	Material number R911...
Rexroth IndraDrive MPx-18 Functions	Application Manual	DOK-INDRV*-MP*-18VRS**- APxx-EN-P	338673
Rexroth IndraDrive MPx-18 Version Notes	Release Notes	DOK-INDRV*-MP*-18VRS**- RNxx-EN-P	338658
Rexroth IndraDrive MPx-16 to MPx-18 Parameters	Reference Book	DOK-INDRV*-GEN1-PARA**- RExx-EN-P	328651
Rexroth IndraDrive MPx-16 to MPx-18 Diagnostic Messages	Reference Book	DOK-INDRV*-GEN1-DIAG**- RExx-EN-P	326738
Rexroth IndraDrive Integrated Safety Technology as of MPx-1x (Safe Torque Off)	Application Manual	DOK-INDRV*-SI3-**VRS**-APxx- EN-P	332634
Rexroth IndraDrive Integrated Safety Technology as of MPx-1x (Safe Motion)	Application Manual	DOK-INDRV*-SI3*SMO-VRS- APxx-EN-P	338920
Rexroth IndraDrive Rexroth IndraMotion MLD (2G) Libraries as of MPx-18	Reference Book	DOK-INDRV*-MLD-SYSLIB3- RExx-EN-P	338916
Rexroth IndraDrive Rexroth IndraMotion MLD (2G) as of MPx-18	Application Manual	DOK-INDRV*-MLD3-**VRS*- APxx-EN-P	338914
Rexroth IndraDrive Rexroth IndraMotion MLD (2G) as of MPx-18	Commissioning Manual	DOK-INDRV*-MLD3-F*STEP- COxx-EN-P	341708
Rexroth IndraMotion MLD 13VRS Service Tool	Reference Book	DOK-IM*MLD-IMST****V13-RExx- EN-P	341347

1) In the document typecodes, "xx" is a wild card for the current edition of the documentation (example: RE02 is the second edition of a Reference Book)

Tab. 1-12: Documentations – Firmware

System Presentation

Title	Kind of documentation	Document typecode ¹⁾	Material number R911...
Productivity Agent Extended Diagnostic Functions with Rexroth IndraDrive	Application Manual	DOK-INDRV*-MLD-PAGENT* AWxx-EN-P	323947

1) In the document typecodes, "xx" is a wild card for the current edition of the documentation (example: AW01 is the first edition of an Application Manual)

Tab. 1-13: Documentations – Overview

System Presentation

1.9.3 Your Feedback



Your experience is important for our improvement processes of products and documentations.

Inform us about mistakes you discovered in this documentation and changes you suggest; we would be grateful for your feedback.

Please send your remarks to:

Address for Your Feedback

Bosch Rexroth AG

Dept. DC-IA/EDY1

Buergermeister-Dr.-Nebel-Str. 2

97816 Lohr, Germany

E-mail: dokusupport@boschrexroth.de

2 Important Directions for Use

2.1 Appropriate Use

2.1.1 Introduction

Rexroth products reflect the state-of-the-art in their development and their manufacture. They are tested prior to delivery to ensure operating safety and reliability.

⚠ WARNING

Personal injury and property damage caused by incorrect use of the products!

The products have been designed for use in industrial environments and may only be used in the appropriate way. If they are not used in the appropriate way, situations resulting in property damage and personal injury can occur.



Rexroth as manufacturer is not liable for any damages resulting from inappropriate use. In such cases, the guarantee and the right to payment of damages resulting from inappropriate use are forfeited. The user alone carries all responsibility of the risks.

Before using Rexroth products, the following pre-requisites must be met to ensure appropriate use of the products:

- Personnel that in any way, shape or form uses our products must first read and understand the relevant safety instructions and be familiar with their appropriate use.
- If the products take the form of hardware, then they must remain in their original state, in other words, no structural changes are permitted. It is not permitted to decompile software products or alter source codes.
- Damaged or faulty products may not be installed or put into operation.
- Make sure that the products have been installed in the manner described in the relevant documentation.

2.1.2 Areas of Use and Application

Drive controllers made by Rexroth are designed to control electrical motors and monitor their operation.

Control and monitoring of the Drive controllers may require additional sensors and actors.



The drive controllers may only be used with the accessories and parts specified in this documentation. If a component has not been specifically named, then it may neither be mounted nor connected. The same applies to cables and lines.

Operation is only permitted in the specified configurations and combinations of components using the software and firmware as specified in the relevant Functional Descriptions.

Drive controllers have to be programmed before commissioning to ensure that the motor executes the specific functions of an application.

Drive controllers of the Rexroth IndraDrive line have been developed for use in single- and multi-axis drive and control tasks.

Important Directions for Use

To ensure application-specific use of Drive controllers, device types of different drive power and different interfaces are available.

Typical applications include, for example:

- Handling and mounting systems,
- Packaging and food machines,
- Printing and paper processing machines and
- Machine tools.

Drive controllers may only be operated under the assembly and installation conditions described in this documentation, in the specified position of normal use and under the ambient conditions as described (temperature, degree of protection, humidity, EMC, etc.).

2.2 Inappropriate Use

Using the Drive controllers outside of the operating conditions described in this documentation and outside of the technical data and specifications given is defined as "inappropriate use".

Drive controllers may not be used, if ...

- they are subject to operating conditions that do not meet the specified ambient conditions. This includes, for example, operation under water, under extreme temperature fluctuations or extremely high maximum temperatures.
- Furthermore, Drive controllers may not be used in applications which have not been expressly authorized by Rexroth. Please carefully follow the specifications outlined in the general Safety Instructions!



Components of the Rexroth IndraDrive system are **products of category C3** (with limited availability) according to IEC 61800-3. To ensure that this category (limit values) is maintained, suitable line filters must be used in the drive system.

These components are not provided for use in a public low-voltage network supplying residential areas with power. If these components are used in such a public network, high-frequency interference is to be expected. This can require additional measures of radio interference suppression.

3 Safety Instructions for Electric Drives and Controls

3.1 Definitions of Terms

Application Documentation	Application documentation comprises the entire documentation used to inform the user of the product about the use and safety-relevant features for configuring, integrating, installing, mounting, commissioning, operating, maintaining, repairing and decommissioning the product. The following terms are also used for this kind of documentation: Operating Instructions, Commissioning Manual, Instruction Manual, Project Planning Manual, Application Description, etc.
Component	A component is a combination of elements with a specified function, which are part of a piece of equipment, device or system. Components of the electric drive and control system are, for example, supply units, drive controllers, mains choke, mains filter, motors, cables, etc.
Control System	A control system comprises several interconnected control components placed on the market as a single functional unit.
Device	A device is a finished product with a defined function, intended for users and placed on the market as an individual piece of merchandise.
Electrical Equipment	Electrical equipment encompasses all devices used to generate, convert, transmit, distribute or apply electrical energy, such as electric motors, transformers, switching devices, cables, lines, power-consuming devices, circuit board assemblies, plug-in units, control cabinets, etc.
Electric Drive System	An electric drive system comprises all components from mains supply to motor shaft; this includes, for example, electric motor(s), motor encoder(s), supply units and drive controllers, as well as auxiliary and additional components, such as mains filter, mains choke and the corresponding lines and cables.
Installation	An installation consists of several devices or systems interconnected for a defined purpose and on a defined site which, however, are not intended to be placed on the market as a single functional unit.
Machine	A machine is the entirety of interconnected parts or units at least one of which is movable. Thus, a machine consists of the appropriate machine drive elements, as well as control and power circuits, which have been assembled for a specific application. A machine is, for example, intended for processing, treatment, movement or packaging of a material. The term "machine" also covers a combination of machines which are arranged and controlled in such a way that they function as a unified whole.
Manufacturer	The manufacturer is an individual or legal entity bearing responsibility for the design and manufacture of a product which is placed on the market in the individual's or legal entity's name. The manufacturer can use finished products, finished parts or finished elements, or contract out work to subcontractors. However, the manufacturer must always have overall control and possess the required authority to take responsibility for the product.
Product	Examples of a product: Device, component, part, system, software, firmware, among other things.
Project Planning Manual	A project planning manual is part of the application documentation used to support the sizing and planning of systems, machines or installations.
Qualified Persons	In terms of this application documentation, qualified persons are those persons who are familiar with the installation, mounting, commissioning and operation of the components of the electric drive and control system, as well as with the hazards this implies, and who possess the qualifications their work

Safety Instructions for Electric Drives and Controls

requires. To comply with these qualifications, it is necessary, among other things,

- 1) to be trained, instructed or authorized to switch electric circuits and devices safely on and off, to ground them and to mark them
- 2) to be trained or instructed to maintain and use adequate safety equipment
- 3) to attend a course of instruction in first aid

User A user is a person installing, commissioning or using a product which has been placed on the market.

3.2 General Information

3.2.1 Using the Safety Instructions and Passing Them on to Others

Do not attempt to install and operate the components of the electric drive and control system without first reading all documentation provided with the product. Read and understand these safety instructions and all user documentation prior to working with these components. If you do not have the user documentation for the components, contact your responsible Rexroth sales partner. Ask for these documents to be sent immediately to the person or persons responsible for the safe operation of the components.

If the component is resold, rented and/or passed on to others in any other form, these safety instructions must be delivered with the component in the official language of the user's country.

Improper use of these components, failure to follow the safety instructions in this document or tampering with the product, including disabling of safety devices, could result in property damage, injury, electric shock or even death.

3.2.2 Requirements for Safe Use

Read the following instructions before initial commissioning of the components of the electric drive and control system in order to eliminate the risk of injury and/or property damage. You must follow these safety instructions.

- Rexroth is not liable for damages resulting from failure to observe the safety instructions.
- Read the operating, maintenance and safety instructions in your language before commissioning. If you find that you cannot completely understand the application documentation in the available language, please ask your supplier to clarify.
- Proper and correct transport, storage, mounting and installation, as well as care in operation and maintenance, are prerequisites for optimal and safe operation of the component.
- Only qualified persons may work with components of the electric drive and control system or within its proximity.
- Only use accessories and spare parts approved by Rexroth.
- Follow the safety regulations and requirements of the country in which the components of the electric drive and control system are operated.
- Only use the components of the electric drive and control system in the manner that is defined as appropriate. See chapter "Appropriate Use".
- The ambient and operating conditions given in the available application documentation must be observed.
- Applications for functional safety are only allowed if clearly and explicitly specified in the application documentation "Integrated Safety Technolo-

Safety Instructions for Electric Drives and Controls

gy". If this is not the case, they are excluded. Functional safety is a safety concept in which measures of risk reduction for personal safety depend on electrical, electronic or programmable control systems.

- The information given in the application documentation with regard to the use of the delivered components contains only examples of applications and suggestions.

The machine and installation manufacturers must

- make sure that the delivered components are suited for their individual application and check the information given in this application documentation with regard to the use of the components,
- make sure that their individual application complies with the applicable safety regulations and standards and carry out the required measures, modifications and complements.
- Commissioning of the delivered components is only allowed once it is sure that the machine or installation in which the components are installed complies with the national regulations, safety specifications and standards of the application.
- Operation is only allowed if the national EMC regulations for the application are met.
- The instructions for installation in accordance with EMC requirements can be found in the section on EMC in the respective application documentation.

The machine or installation manufacturer is responsible for compliance with the limit values as prescribed in the national regulations.

- The technical data, connection and installation conditions of the components are specified in the respective application documentations and must be followed at all times.

National regulations which the user must take into account

- European countries: In accordance with European EN standards
- United States of America (USA):
 - National Electrical Code (NEC)
 - National Electrical Manufacturers Association (NEMA), as well as local engineering regulations
 - Regulations of the National Fire Protection Association (NFPA)
- Canada: Canadian Standards Association (CSA)
- Other countries:
 - International Organization for Standardization (ISO)
 - International Electrotechnical Commission (IEC)

3.2.3 Hazards by Improper Use

- High electrical voltage and high working current! Danger to life or serious injury by electric shock!
- High electrical voltage by incorrect connection! Danger to life or injury by electric shock!
- Dangerous movements! Danger to life, serious injury or property damage by unintended motor movements!
- Health hazard for persons with heart pacemakers, metal implants and hearing aids in proximity to electric drive systems!

Safety Instructions for Electric Drives and Controls

- Risk of burns by hot housing surfaces!
- Risk of injury by improper handling! Injury by crushing, shearing, cutting, hitting!
- Risk of injury by improper handling of batteries!
- Risk of injury by improper handling of pressurized lines!

3.3 Instructions with Regard to Specific Dangers

3.3.1 Protection Against Contact with Electrical Parts and Housings



This section concerns components of the electric drive and control system with voltages of **more than 50 volts**.

Contact with parts conducting voltages above 50 volts can cause personal danger and electric shock. When operating components of the electric drive and control system, it is unavoidable that some parts of these components conduct dangerous voltage.

High electrical voltage! Danger to life, risk of injury by electric shock or serious injury!

- Only qualified persons are allowed to operate, maintain and/or repair the components of the electric drive and control system.
- Follow the general installation and safety regulations when working on power installations.
- Before switching on, the equipment grounding conductor must have been permanently connected to all electric components in accordance with the connection diagram.
- Even for brief measurements or tests, operation is only allowed if the equipment grounding conductor has been permanently connected to the points of the components provided for this purpose.
- Before accessing electrical parts with voltage potentials higher than 50 V, you must disconnect electric components from the mains or from the power supply unit. Secure the electric component from reconnection.
- With electric components, observe the following aspects:
 - Always wait **30 minutes** after switching off power to allow live capacitors to discharge before accessing an electric component. Measure the electrical voltage of live parts before beginning to work to make sure that the equipment is safe to touch.
- Install the covers and guards provided for this purpose before switching on.
- Never touch electrical connection points of the components while power is turned on.
- Do not remove or plug in connectors when the component has been powered.
- Under specific conditions, electric drive systems can be operated at mains protected by residual-current-operated circuit-breakers sensitive to universal current (RCDs/RCMs).

Safety Instructions for Electric Drives and Controls

- Secure built-in devices from penetrating foreign objects and water, as well as from direct contact, by providing an external housing, for example a control cabinet.

High housing voltage and high leakage current! Danger to life, risk of injury by electric shock!

- Before switching on and before commissioning, ground or connect the components of the electric drive and control system to the equipment grounding conductor at the grounding points.
- Connect the equipment grounding conductor of the components of the electric drive and control system permanently to the main power supply at all times. The leakage current is greater than 3.5 mA.
- Establish an equipment grounding connection with a minimum cross section according to the table below. With an outer conductor cross section smaller than 10 mm² (8 AWG), the alternative connection of two equipment grounding conductors is allowed, each having the same cross section as the outer conductors.

Cross section outer conductor	Minimum cross section equipment grounding conductor Leakage current ≥ 3.5 mA	
	1 equipment grounding conductor	2 equipment grounding conductors
1.5 mm ² (16 AWG)	10 mm ² (8 AWG)	2 × 1.5 mm ² (16 AWG)
2.5 mm ² (14 AWG)		2 × 2.5 mm ² (14 AWG)
4 mm ² (12 AWG)		2 × 4 mm ² (12 AWG)
6 mm ² (10 AWG)		2 × 6 mm ² (10 AWG)
10 mm ² (8 AWG)		-
16 mm ² (6 AWG)	16 mm ² (6 AWG)	-
25 mm ² (4 AWG)		-
35 mm ² (2 AWG)		-
50 mm ² (1/0 AWG)	25 mm ² (4 AWG)	-
70 mm ² (2/0 AWG)	35 mm ² (2 AWG)	-
...

Tab.3-1: Minimum Cross Section of the Equipment Grounding Connection

3.3.2 Protective Extra-Low Voltage as Protection Against Electric Shock

Protective extra-low voltage is used to allow connecting devices with basic insulation to extra-low voltage circuits.

On components of an electric drive and control system provided by Rexroth, all connections and terminals with voltages up to 50 volts are PELV ("Protective Extra-Low Voltage") systems. It is allowed to connect devices equipped with basic insulation (such as programming devices, PCs, notebooks, display units) to these connections.

Safety Instructions for Electric Drives and Controls

Danger to life, risk of injury by electric shock! High electrical voltage by incorrect connection!

If extra-low voltage circuits of devices containing voltages and circuits of more than 50 volts (e.g., the mains connection) are connected to Rexroth products, the connected extra-low voltage circuits must comply with the requirements for PELV ("Protective Extra-Low Voltage").

3.3.3 Protection Against Dangerous Movements

Dangerous movements can be caused by faulty control of connected motors. Some common examples are:

- Improper or wrong wiring or cable connection
- Operator errors
- Wrong input of parameters before commissioning
- Malfunction of sensors and encoders
- Defective components
- Software or firmware errors

These errors can occur immediately after equipment is switched on or even after an unspecified time of trouble-free operation.

The monitoring functions in the components of the electric drive and control system will normally be sufficient to avoid malfunction in the connected drives. Regarding personal safety, especially the danger of injury and/or property damage, this alone cannot be relied upon to ensure complete safety. Until the integrated monitoring functions become effective, it must be assumed in any case that faulty drive movements will occur. The extent of faulty drive movements depends upon the type of control and the state of operation.

Dangerous movements! Danger to life, risk of injury, serious injury or property damage!

A **risk assessment** must be prepared for the installation or machine, with its specific conditions, in which the components of the electric drive and control system are installed.

As a result of the risk assessment, the user must provide for monitoring functions and higher-level measures on the installation side for personal safety. The safety regulations applicable to the installation or machine must be taken into consideration. Unintended machine movements or other malfunctions are possible if safety devices are disabled, bypassed or not activated.

To avoid accidents, injury and/or property damage:

- Keep free and clear of the machine's range of motion and moving machine parts. Prevent personnel from accidentally entering the machine's range of motion by using, for example:
 - Safety fences
 - Safety guards
 - Protective coverings
 - Light barriers
- Make sure the safety fences and protective coverings are strong enough to resist maximum possible kinetic energy.
- Mount emergency stopping switches in the immediate reach of the operator. Before commissioning, verify that the emergency stopping equip-

Safety Instructions for Electric Drives and Controls

ment works. Do not operate the machine if the emergency stopping switch is not working.

- Prevent unintended start-up. Isolate the drive power connection by means of OFF switches/OFF buttons or use a safe starting lockout.
- Make sure that the drives are brought to safe standstill before accessing or entering the danger zone.
- Additionally secure vertical axes against falling or dropping after switching off the motor power by, for example,
 - mechanically securing the vertical axes,
 - adding an external braking/arrester/clamping mechanism or
 - ensuring sufficient counterbalancing of the vertical axes.
- The standard equipment **motor holding brake** or an external holding brake controlled by the drive controller is **not sufficient to guarantee personal safety!**
- Disconnect electrical power to the components of the electric drive and control system using the master switch and secure them from reconnection ("lock out") for:
 - Maintenance and repair work
 - Cleaning of equipment
 - Long periods of discontinued equipment use
- Prevent the operation of high-frequency, remote control and radio equipment near components of the electric drive and control system and their supply leads. If the use of these devices cannot be avoided, check the machine or installation, at initial commissioning of the electric drive and control system, for possible malfunctions when operating such high-frequency, remote control and radio equipment in its possible positions of normal use. It might possibly be necessary to perform a special electromagnetic compatibility (EMC) test.

3.3.4 Protection Against Magnetic and Electromagnetic Fields During Operation and Mounting

Magnetic and electromagnetic fields generated by current-carrying conductors or permanent magnets of electric motors represent a serious danger to persons with heart pacemakers, metal implants and hearing aids.

Health hazard for persons with heart pacemakers, metal implants and hearing aids in proximity to electric components!

- Persons with heart pacemakers and metal implants are not allowed to enter the following areas:
 - Areas in which components of the electric drive and control systems are mounted, commissioned and operated.
 - Areas in which parts of motors with permanent magnets are stored, repaired or mounted.
- If it is necessary for somebody with a heart pacemaker to enter such an area, a doctor must be consulted prior to doing so. The noise immunity of implanted heart pacemakers differs so greatly that no general rules can be given.
- Those with metal implants or metal pieces, as well as with hearing aids, must consult a doctor before they enter the areas described above.

Safety Instructions for Electric Drives and Controls

3.3.5 Protection Against Contact with Hot Parts

Hot surfaces of components of the electric drive and control system. Risk of burns!

- Do not touch hot surfaces of, for example, braking resistors, heat sinks, supply units and drive controllers, motors, windings and laminated cores!
- According to the operating conditions, temperatures of the surfaces can be **higher than 60 °C** (140 °F) during or after operation.
- Before touching motors after having switched them off, let them cool down for a sufficient period of time. Cooling down can require **up to 140 minutes!** The time required for cooling down is approximately five times the thermal time constant specified in the technical data.
- After switching chokes, supply units and drive controllers off, wait **15 minutes** to allow them to cool down before touching them.
- Wear safety gloves or do not work at hot surfaces.
- For certain applications, and in accordance with the respective safety regulations, the manufacturer of the machine or installation must take measures to avoid injuries caused by burns in the final application. These measures can be, for example: Warnings at the machine or installation, guards (shieldings or barriers) or safety instructions in the application documentation.

3.3.6 Protection During Handling and Mounting

Risk of injury by improper handling! Injury by crushing, shearing, cutting, hitting!

- Observe the relevant statutory regulations of accident prevention.
- Use suitable equipment for mounting and transport.
- Avoid jamming and crushing by appropriate measures.
- Always use suitable tools. Use special tools if specified.
- Use lifting equipment and tools in the correct manner.
- Use suitable protective equipment (hard hat, safety goggles, safety shoes, safety gloves, for example).
- Do not stand under hanging loads.
- Immediately clean up any spilled liquids from the floor due to the risk of falling!

3.3.7 Battery Safety

Batteries consist of active chemicals in a solid housing. Therefore, improper handling can cause injury or property damage.

Risk of injury by improper handling!

- Do not attempt to reactivate low batteries by heating or other methods (risk of explosion and cauterization).
- Do not attempt to recharge the batteries as this may cause leakage or explosion.
- Do not throw batteries into open flames.
- Do not dismantle batteries.

Safety Instructions for Electric Drives and Controls

- When replacing the battery/batteries, do not damage the electrical parts installed in the devices.
- Only use the battery types specified for the product.



Environmental protection and disposal! The batteries contained in the product are considered dangerous goods during land, air, and sea transport (risk of explosion) in the sense of the legal regulations. Dispose of used batteries separately from other waste. Observe the national regulations of your country.

3.3.8 Protection Against Pressurized Systems

According to the information given in the Project Planning Manuals, motors and components cooled with liquids and compressed air can be partially supplied with externally fed, pressurized media, such as compressed air, hydraulics oil, cooling liquids and cooling lubricants. Improper handling of the connected supply systems, supply lines or connections can cause injuries or property damage.

Risk of injury by improper handling of pressurized lines!

- Do not attempt to disconnect, open or cut pressurized lines (risk of explosion).
- Observe the respective manufacturer's operating instructions.
- Before dismantling lines, relieve pressure and empty medium.
- Use suitable protective equipment (safety goggles, safety shoes, safety gloves, for example).
- Immediately clean up any spilled liquids from the floor due to the risk of falling!



Environmental protection and disposal! The agents (e.g., fluids) used to operate the product might not be environmentally friendly. Dispose of agents harmful to the environment separately from other waste. Observe the national regulations of your country.

3.4 Explanation of Signal Words and the Safety Alert Symbol

The Safety Instructions in the available application documentation contain specific signal words (DANGER, WARNING, CAUTION or NOTICE) and, where required, a safety alert symbol (in accordance with ANSI Z535.6-2011).

The signal word is meant to draw the reader's attention to the safety instruction and identifies the hazard severity.

The safety alert symbol (a triangle with an exclamation point), which precedes the signal words DANGER, WARNING and CAUTION, is used to alert the reader to personal injury hazards.

 **DANGER**

In case of non-compliance with this safety instruction, death or serious injury will occur.

Safety Instructions for Electric Drives and Controls

⚠ WARNING

In case of non-compliance with this safety instruction, death or serious injury **could** occur.

⚠ CAUTION

In case of non-compliance with this safety instruction, minor or moderate injury could occur.

NOTICE

In case of non-compliance with this safety instruction, property damage could occur.

4 Brief Description, Usage

4.1 General Information

In terms of "Appropriate Use", cases of operation and applications not mentioned in this chapter are not allowed.



In this context, observe the chapter [8 Configuring the Drive System](#), page 93.

4.2 Applications of the Drive System Rexroth IndraDrive

The digital, intelligent drive system Rexroth IndraDrive is the cost-efficient solution with a high degree of functionality for single-axis and multi-axis drive and control tasks.

The drive system Rexroth IndraDrive fulfills a large number of drive tasks in the most varied applications.

Typical applications are the industrial sectors:

- Printing and paper converting
- Packaging and food
- Mounting and handling
- Wood machining
- Machine tools
- Metal forming
- General automation

For these applications there are different device types of graduated performance.

4.3 Mains Transformers DST and DLT

DST and DLT transformers are used to transform mains voltages to the allowed nominal voltages of the devices.

DLT transformers are used to

- prevent overvoltage between outer conductor and ground
- protect other loads against leakage currents

Type	Usage
DST autotransformer	Adjusting voltage range in grounded mains
DLT isolating transformer	Adjusting voltage range in ungrounded mains

Tab.4-1: Usage of Transformers



As a matter of principle, DLT isolating transformers have to be used at ungrounded mains.

4.4 Mains Filters HNF, HNK, NFE, HNS02 and NFD

Mains filters reduce radio interference and mains pollution.

Brief Description, Usage



When using mains filters HNF01, NFD03, HNS02 and HNK01 at **mains grounded via outer conductor**, use an isolating transformer between mains and mains filter.

Type	Usage
NFE01.1	Interference suppression of power supply units up to 230 V
NFE02.1	Interference suppression of single-phase drive controllers up to 230 V
NFD03.1	Interference suppression of three-phase drive controllers up to 480 V for 1–6 axes and motor cable lengths up to max. 75 m single-axis / 120 m multi-axis (HCS02.1E)
HNF01.1	Interference suppression of three-phase drive controllers up to 480 V for drive systems with a high number of axes and long motor cables
HNK01.1	Interference suppression of three-phase drive controllers HCS03.1E up to 500 V
HNS02	Interference suppression of three-phase drive controllers up to 480 V for drive systems with a maximum of 12 axes and a maximum of 200 m motor cable length Integrated switch-disconnector

Tab.4-2: Usage of Mains Filters



Only operate expressly allowed components at the mentioned mains filters. Operating, for example, blowers, pumps etc. at HNF mains filters is not allowed.

4.5 Mains Chokes HNL01 and HNL02

(Standard) mains chokes HNL01.1E, HNL01.1R and HNL02.1R

- reduce harmonics in the mains current
- increase the allowed DC bus continuous power of certain converters
- allow operating regenerative supply units at the mains

Current-compensated mains chokes HNL01.1E-****-S and HNL01.1R-****-S reduce asymmetric currents (leakage currents) in the mains connection phase of the drive system.

The different types may be used **exclusively** as follows:

Type	Usage
HNL01.1R	For connection to components with regeneration to the supply mains (HMV01.1R)
HNL01.1E	For connection to components without regeneration to the supply mains (HMV01.1E, HCS02.1E, HCS03.1E)

Brief Description, Usage

Type	Usage
HNL01.1*-***-S	Current-compensated chokes for use with HNL01.1 mains chokes to reduce asymmetric currents (leakage currents) in the mains connection phase of the drive system (HMV01.1E, HMV01.1R, HCS02.1E, HCS03.1E)
HNL02.1R	Mains chokes in housing for control cabinet mounting for connection to components with regeneration to the supply mains (HMV02.1R)

Tab.4-3: Usage of Mains Chokes

4.6 Supply Units HMV01 / HMV02

HMV supply units supply modular HMS and HMD drive controllers.

Type	Usage
HMV01.1E	Infeeding Supplies HMS01 and HMD01 drive controllers
HMV01.1R	Regenerative Supplies HMS01 and HMD01 drive controllers
HMV02.1R	Regenerative Supplies HMS01, HMS02 and HMD01 drive controllers

Tab.4-4: Usage of Supply Units

4.7 Drive Controllers HMS01, HMS02 and HMD01

In the modular drive system, HMS and HMD drive controllers control single and double axes.

Type	Usage
HMD01.1	<ul style="list-style-type: none"> Have two power outputs to operate two motors independently of each other Are operated at HMV supply units and HCS drive controllers
HMS01.1	<ul style="list-style-type: none"> Have a power output to operate a motor Are operated at HMV01 supply units and HCS02 and HCS03 drive controllers
HMS02.1	<ul style="list-style-type: none"> Have a power output to operate a motor Are operated at HMV02 supply units and HCS02 drive controllers

Tab.4-5: Usage of HM* Drive Controllers

4.8 Control Sections CSB, CSE, CSH, CDB

CSB, CSE, CSH and CDB control sections:

- Allow operating HCS, HMS, HMD drive controllers
- Fulfill open-loop and closed-loop control tasks with analog command value input
- Require a certain firmware:
 - CSB01, CSH01, CDB01: ≤ MPx08

Brief Description, Usage

- CSB02, CSH02, CDB02, CSE02: \geq MPx18

Type	Usage
CSH	Advanced In HMS01, HMS02, HCS02, HCS03 drive controllers
CSB	BASIC - single-axis In HMS01, HMS02, HCS02, HCS03 drive controllers
CSE	ECONOMY - single-axis In HMS01, HMS02, HCS02, HCS03 drive controllers
CDB	BASIC - double-axis In HMD01 drive controllers

Tab.4-6: Usage of Control Sections

4.9 Drive Controllers HCS02

HCS02 drive controllers control single axes.

Type	Usage
HCS02	<ul style="list-style-type: none"> • Have a power output to operate a motor • Power range: 1.5 kW to 11 kW

Tab.4-7: Usage of HCS02 Drive Controllers

4.10 Drive Controllers HCS03

HCS03 drive controllers control single axes.

Type	Usage
HCS03	<ul style="list-style-type: none"> • Have a power output to operate a motor • Power range: 18.5 kW to 75 kW

Tab.4-8: Usage of HCS03 Drive Controllers



In their standard design -NNNV, HCS03 drive controllers are not regenerative.

For applications where regenerative power is generated, use HCS03.1 of the -NNBV design and HLR braking resistors.

4.11 Components KCU, KSM, KMS

Type	Usage
KCU01	Drive connection box to connect KSM01/KMS01 to HMV supply units or HCS converters
KCU02	Drive connection box to connect KSM02/KMS02 to HMV supply units or HCS converters

Type	Usage
KSM01 KSM02	Motor-integrated servo drives: Synchronous servo motors (on the basis of Rexroth IndraDyn S) with integrated inverters and control sections
KMS01 KMS02	Near motor servo drives: Very compact inverters with control sections

Tab.4-9: Components KCU, KSM, KMS

4.12 DC Bus Resistor Unit HLB01

DC bus resistor units HLB01

- Convert generated kinetic energy into thermal energy
- Increase the continuous regenerative power in the drive system
- Increase the peak regenerative power in the drive system
- Allow the DC bus short circuit function ("ZKS") in the drive system

Type	Usage
HLB01.1C	In drive systems of the Rexroth IndraDrive C product range with a device mounting depth of 265 mm.
HLB01.1D	In drive systems of the Rexroth IndraDrive M product range with a device mounting depth of 322 mm.

Tab.4-10: DC Bus Resistor Units HLB

4.13 Braking Resistor HLR01

HLR01.1N-xxxx-Nxxx-A-007-NNNN braking resistors convert generated kinetic energy into thermal energy. For this purpose, the line covers a wide range of continuous power and energy absorption capacity.

Type	Usage
HLR01.1A	Type of construction A (version for device mounting): To be mounted to drive controllers of the Rexroth IndraDrive C product range. For this purpose, the drive controllers must be equipped with a brake chopper.
HLR01.1N	Type of construction N (version for free assembly): For free assembly in the installation, operated by drive controller of the Rexroth IndraDrive C product range. For this purpose, the drive controllers must be equipped with a brake chopper.

Tab.4-11: Braking Resistors HLR

Designs of type of construction N:

- Fixed resistor IP 20 **type A**
Cement-coated, wire-wound, tube-type fixed resistors; screwed on side walls; perforated cover; connections in terminal box with PG gland
- Steel-grid fixed resistor IP 20 **type B**
Fixed resistor in steel-grid design; connection depending on type
- Steel-grid fixed Resistor IP 20 **type C**
Fixed resistor in steel-grid design; connection depending on type

Brief Description, Usage

4.14 DC Bus Capacitor Unit HLC01

DC bus capacitor units HLC01 store energy in the DC bus of the drive system.

Type	Usage
HLC01.1C	In drive systems of the product ranges Rexroth IndraDrive C and Rexroth IndraDrive M
HLC01.1D	In drive systems of the product ranges Rexroth IndraDrive C and Rexroth IndraDrive M

Tab.4-12: DC Bus Capacitor Units HLC

4.15 Fan Unit HAB01

HAB01 fan units cool specific HMV01 and HMS01 devices.

Type	Usage
HAB01.1	At HMS01.1N-W0350 drive controllers At HMV01.1R-W0120 supply units

Tab.4-13: Usage of HAB01 Fan Unit

4.16 Motor Filters HMF01

HMF01 motor filters

- reduce the rise of the output voltage of drive controllers
- reduce leakage currents of the motor lines
- reduce interference voltage on the motor lines

Type	Usage
HMF01.1	At the motor output of HCS drive controllers

Tab.4-14: Usage of HMF01 Motor Filters

4.17 Accessories HAS

The HAS accessories support the operation and combination of components in the Rexroth IndraDrive system.

4.18 Housing for Control Sections HAC01

Additional components HAC01 are used to

- insert control sections in them
- supply control sections with 24V control voltage

Type	Usage
HAC01.1-002-NNN-NN	To insert CDB control sections in it

Tab.4-15: HAC01 Type

4.19 Hall Sensor Box SHL

The additional component SHL is used when the commutation setting of linear motors (e.g., IndraDyn L and LSF) is to be carried out, mechanical move-

Brief Description, Usage

ment mustn't take place and the automatic commutation methods of the drive firmware cannot be used.

The drive firmware provides automatic commutation methods which can be used for sophisticated motion tasks.

 See also Functional Description of the firmware, index entry "Saturation method" (requires I_{out_max}) and "Sine-wave method" (requires unrestricted movement of the axis).

5 General Data and Specifications

5.1 Acceptance Tests and Approvals

Declaration of Conformity Declarations of conformity confirm that the components comply with the valid EN standards and EC directives. If required, our sales representative can provide you with the declarations of conformity for components.

 <small>DX000011v01_in.FH11</small>	Drive controllers, Supply units	Motors
CE conformity regarding Low-Voltage Directive	EN 61000-5-1:2007	EN 60034-1:2010+Cor.:2010 EN 60034-5:2001+A1:2007
CE conformity regarding EMC product standard	EN 61800-3:2004	

Tab.5-1: CE - Applied Standards

C-UL-US Listing The components are listed by **UL** (Underwriters Laboratories Inc.®). You can find the evidence of certification on the Internet under <http://www.ul.com> under "Certifications" by entering the file number or the "Company Name: Rexroth".

 Listed POW. CONV. EQ. 97Y4 <small>DX000000v01_in.B1</small>	<ul style="list-style-type: none"> • UL standard: UL 508 C • CSA standard: Canadian National Standard C22.2 No. 14-10
	Company Name BOSCH REXROTH ELECTRIC DRIVES & CONTROLS GMBH Category Name: Power Conversion Equipment
	File numbers Rexroth IndraDrive components: <ul style="list-style-type: none"> • E134201 • E227957 The control sections are part of the listed components. The HAB01.1-0350-1640-NN fan unit is part of the listed components HMV01.1R-W0210 and HMS01.1N-W0350.

Tab.5-2: C-UL Listing

General Data and Specifications

**UL ratings**

For using the component in the scope of CSA / UL, take the UL ratings of the individual components into account.

In the scope of CSA / UL, it is exclusively the following components which have been approved to supply the components HMS, HMD, KCU, KSM, KMS:

- HMV01.1E
- HMV01.1R
- HMV02.1R
- HCS02.1E
- HCS03.1E

Make sure that the indicated **short circuit current rating SCCR** is not exceeded, e.g. by appropriate fuses in the mains supply of the supply unit.

**Wiring material UL**

In the scope of CSA / UL, use copper 60/75 °C only; class 1 or equivalent only.

**Allowed pollution degree**

Comply with the allowed pollution degree of the components (see "Ambient and Operating Conditions").

C-UR-US Listing

The motors are listed by **UL** ("Underwriters Laboratories Inc.®"). You can find the evidence of certification on the Internet under <http://www.ul.com> under "Certifications" by entering the file number or the "Company Name: Rexroth".

 <small>CUR_Zeichen.th11</small>	<ul style="list-style-type: none"> • UL standard: UL 1004-1 • CSA standard: Canadian National Standard C22.2 No. 100
	Company Name BOSCH REXROTH ELECTRIC DRIVES & CONTROLS GMBH Category Name: Servo and Stepper Motors - Component
	File numbers MSK, MSM motors: E335445

Tab.5-3: C-UR Listing

**Wiring material UL (ready-made cables by Rexroth)**

In the scope of CSA / UL, use copper 60/75 °C only; class 6 or equivalent only.

**Allowed pollution degree**

Comply with the allowed pollution degree of the components (see "Ambient and Operating Conditions").

General Data and Specifications

CCC (China Compulsory Certification)

The CCC test symbol comprises a compulsory certification of safety and quality for certain products mentioned in the product catalog "First Catalogue of Products Subject to Compulsory Certification" and in the CNCA document "Application Scope for Compulsory Certification of Products acc. first Catalogue" and put in circulation in China. This compulsory certification has been existing since 2003.

CNCA is the Chinese authority responsible for certification directives. When a product is imported in China, the certification will be checked at the customs by means of entries in a database. For the requirement of certification three criteria are normally relevant:

1. Customs tariff number (HS code) according to CNCA document "Application Scope for Compulsory Certification of Products acc. first Catalogue".
2. Scope of application according to CNCA document "Application Scope for Compulsory Certification of Products acc. first Catalogue".
3. For the IEC product standard used, the corresponding Chinese GB standard must exist.

For the drive components by Rexroth described in this documentation, **certification is not required at present**, thus they are not CCC certified. Negative certifications will not be issued.

5.2 Transport and Storage

5.2.1 Transport of the Components

Ambient and Operating Conditions - Transport

Description	Symbol	Unit	Value	
Temperature range	T_{a_tran}	°C	Supply units and drive controllers: KCU: -25 ... +70	Motors: KSM, KMS: -20 ... +80
Relative humidity		%	5 ... 95	
Absolute humidity		g/m ³	1 ... 60	
Climatic category (IEC 721)			2K3	
Moisture condensation			Not allowed	
Icing			Not allowed	

Tab.5-4: Ambient and Operating Conditions - Transport

General Data and Specifications

5.2.2 Storage of the Components

NOTICE

Damage to the component caused by long storage periods!

Some components contain electrolytic capacitors which may deteriorate during storage.

When storing the following components for a longer period of time, operate them **once a year for at least 1 hour**:

- Converters and supply units: Operation with mains voltage U_{LN}
- Inverters and DC bus capacitor units: Operation with DC bus voltage U_{DC}

NOTICE

Risk of damage to the drive connection box KCU by extended storage!

The drive connection box KCU contains electrolytic capacitors which may deteriorate during storage. When storing the drive connection box KCU for a longer period of time, operate it **once a year for at least 1 hour** with 24 V control voltage U_{N3} .

Ambient and Operating Conditions - Storage

Description	Symbol	Unit	Value	
Temperature range	T_{a_store}	°C	Supply units and drive controllers: KCU: -25 ... 55	Motors: KSM, KMS: -20 ... +60
Relative humidity		%	5 ... 95	
Absolute humidity		g/m ³	1 ... 29	
Climatic category (IEC721)			1K3	
Moisture condensation			Not allowed	
Icing			Not allowed	

Tab.5-5: Ambient and Operating Conditions - Storage

5.3 Installation Conditions

5.3.1 Ambient and Operating Conditions



Check that the ambient conditions, in particular the control cabinet temperature, are complied with by calculating the heat levels in the control cabinet. Afterwards, make the corresponding measurements to find out that the ambient conditions have actually been complied with.

In the technical data of the individual components, the power dissipation is indicated as an important input value for calculating the heat levels.

Motor-integrated servo drives KSM and near motor servo drives KMS are designed for use near to the machines and are not installed in control cabinets.

General Data and Specifications

Ambient and Operating Conditions (HCS, HMV, HMS, HMD, HCQ, HCT, KCU, HLC)

Description	Symbol	Unit	Value
Conductive dirt contamination			Not allowed Protected the devices against conductive dirt contamination by mounting them in control cabinets of the degree of protection IP54 (in accordance with IEC 60529).
Degree of protection of the device (IEC 60529)			IP20
Use in the scope of CSA / UL			For use in NFPA 79 Applications only.
Temperature during storage			See chapter 5.2.2 "Storage of the Components" on page 58
Temperature during transport			See chapter 5.2.1 "Transport of the Components" on page 57
Allowed mounting position Definition of mounting positions: See chapter "Mounting Positions of Components" on page 62			G1
Installation altitude	h_{nenn}	m	1000
Ambient temperature range	T_{a_work}	°C	0 ... 40
<p>Derating vs. ambient temperature:</p> <p>In the ambient temperature range $T_{a_work_red}$, the performance data are reduced by the factor F_{Ta}:</p> $F_{Ta} = 1 - [(T_a - 40) \times f_{Ta}]$ <p>For the drive connection box KCU, the rated power (P_{out}) is reduced at the output of the 42 V control voltage. The rated power at the output of the power section (P_{DC_cont}) is not reduced.</p> <p>Example: With an ambient temperature $T_a = 50$ °C and a capacity utilization factor $f_{Ta} = 2$ %/K, the rated power is reduced to</p> $P_{DC_cont_red} = P_{DC_cont} \times F_{Ta} =$ $P_{DC_cont} \times (1 - [(50 - 40) \times 0.02]) = P_{DC_cont} \times 0.8$ <p>Operation at ambient temperatures outside of T_{a_work} and $T_{a_work_red}$ is not allowed!</p>			
	$T_{a_work_red}$	°C	40 ... 55
	f_{Ta}	%/K	2,0 Exception HMV02.1R-W0015-A-07-NNNN: 2,7

General Data and Specifications

Description	Symbol	Unit	Value
<p>Derating vs. installation altitude:</p> <p>With installation altitudes $h > h_{nenn}$, the available performance data are reduced by the factor $f^{(3)}$⁴⁾.</p> <p>With installation altitudes in the range of h_{max_ohne} to h_{max}, an overvoltage limiter against transient overvoltage must be installed in the installation.</p> <p>Operation above h_{max} is not allowed!</p>			
	h_{max_ohne}	m	2000
	h_{max}	m	4000
Simultaneous derating for ambient temperature and installation altitude	Allowed; reduce performance data with the product $f \times F_{Ta}$		
Relative humidity		%	5 ... 95
Absolute humidity		g/m ³	1 ... 29
Climatic category (IEC721)			3K3
Allowed pollution degree (IEC 60664-1)			2
Allowed dust, steam			EN 50178 tab. A.2
Vibration sine: Amplitude (peak-peak) at 5 ... 32 Hz ²⁾		mm	0,6 ±15%
Vibration sine: Acceleration at 32 ... 200 Hz ²⁾		g	1,3 ±15%
Vibration noise (random) frequency ¹⁾		Hz	20 ... 500
Vibration noise (random) spectral acceleration density, amplitude ¹⁾		g ² /Hz	0,05
Vibration noise (random) rms value of total acceleration ¹⁾		g	1,5
Vibration sine: Axial Acceleration at 10 ... 2,000 Hz ²⁾		g	-
Vibration sine: Radial Acceleration at 10 ... 2,000 Hz ²⁾		g	-
Overvoltage category			III (according to IEC60664-1)

1) According to EN 60068-2-64

2) According to EN 60068-2-6

3) Reduced performance data for drive controllers: Allowed DC bus continuous power, braking resistor continuous power, continuous current; for HCS01, HCQ, HCT drive controllers additionally: Allowed mains voltage

4) Reduced performance data for motors: Performance, torque S1 and S3

Tab.5-6: *Ambient and Operating Conditions (HCS, HMV, HMS, HMD, HCQ, HCT, KCU, HLC)*

General Data and Specifications

Ambient and Operating Conditions (KSM, KMS)

Description	Symbol	Unit	Value
Degree of protection (IEC 60529)			IP65
Use in the scope of CSA / UL			For use in NFPA 79 Applications only.
Temperature during storage			See chapter 5.2.2 "Storage of the Components" on page 58
Temperature during transport			See chapter 5.2.1 "Transport of the Components" on page 57
Allowed mounting position Definition of mounting positions: See chapter "Mounting Positions of Components" on page 62			KSM: IM B5, IM V1, IM V3 KMS: G1, G2, G3, G4, G5
Installation altitude	h_{nenn}	m	1000
Ambient temperature range	T_{a_work}	°C	0 ... 40
<p>Derating vs. ambient temperature: In the ambient temperature range $T_{a_work_red}$, the performance data are reduced by the factor F_{Ta}:</p> $F_{Ta} = 1 - [(T_a - 40) \times f_{Ta}]$ <p>Example: With an ambient temperature $T_a = 50$ °C and a capacity utilization factor $f_{Ta} = 3$ %/K, the rated power is reduced to</p> $P_{DC_cont_red} = P_{DC_cont} \times F_{Ta} =$ $P_{DC_cont} \times (1 - [(50 - 40) \times 0.03]) = P_{DC_cont} \times 0.7$ <p>Operation at ambient temperatures outside of T_{a_work} and $T_{a_work_red}$ is not allowed!</p>	<p style="text-align: right; font-size: small;">DK0001246v3_mn.h11</p>		
	$T_{a_work_red}$	°C	40 ... 55
	f_{Ta}	%/K	3
<p>Derating vs. installation altitude: With installation altitudes $h > h_{nenn}$, the available performance data are reduced by the factor f⁴⁾.</p> <p>With installation altitudes in the range of h_{max_ohne} to h_{max}, an overvoltage limiter against transient overvoltage must be installed in the installation.</p> <p>Operation above h_{max} is not allowed!</p>	<p style="text-align: right; font-size: small;">DK0001304v2_mn.h11</p>		
	h_{max_ohne}	m	2000
	h_{max}	m	4000
Simultaneous derating for ambient temperature and installation altitude	Allowed; reduce performance data with the product of the factors f and F_{Ta} ($f \times F_{Ta}$)		
Relative humidity		%	5 ... 95
Absolute humidity		g/m ³	1 ... 29
Climatic category (IEC721)			3K4
Allowed pollution degree (IEC 60664-1)			3 (only with connectors plugged in)

General Data and Specifications

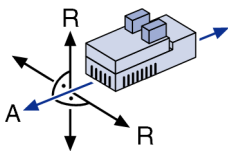
Description	Symbol	Unit	Value
Maximum concentration of corrosive gases			According to degree of protection
Vibration sine: Amplitude (peak-peak) at 10 ... 57 Hz ¹⁾		mm	-
Vibration sine: Acceleration at 57 ... 150 Hz ¹⁾		g	-
Vibration noise (random) frequency ¹⁾		Hz	-
Vibration noise (random) spectral acceleration density, amplitude ¹⁾		g ² /Hz	-
Vibration noise (random) rms value of total acceleration ¹⁾		g	-
Vibration sine: Axial Acceleration at 10 ... 2,000 Hz ²⁾		g	1 With accessory HAS10.1-001-001-NN: KSM: 1 KMS: 3
For KMS: Axial (A), radial (R)			
			
Vibration sine: Radial Acceleration at 10 ... 2,000 Hz ²⁾		g	1 With accessory HAS10.1-001-001-NN: KSM: 3 KMS: 3
Overvoltage category			III (according to IEC60664-1)

1) According to EN 60068-2-64

2) According to EN 60068-2-6

3) Reduced performance data for drive controllers: Allowed DC bus continuous power, braking resistor continuous power, continuous current

4) Reduced performance data for motors: Performance, torque S1 and S3

Tab.5-7: Ambient and Operating Conditions (KSM, KMS)

5.3.2 Mounting Position

Mounting Positions of Components

NOTICE

Risk of damage to the components by incorrect mounting position!

Only operate the components in their allowed mounting positions. The allowed mounting positions are specified in the technical data of the components.

The only mounting position allowed for supply units and drive controllers to be installed in control cabinets is G1.

Mounting Positions

The technical data of the components specifies the allowed mounting positions as G1, G2, G3, G4, or G5.

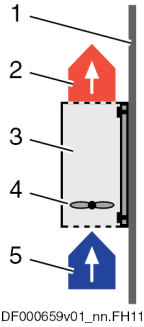
Mounting position	Description
G1	 <p>DF000659v01_nn.FH11</p> <p>Normal mounting position</p> <p>The air that is heated inside the component can flow out of the component in a vertical upward direction. Natural convection supports the forced cooling air current. This avoids the generation of pockets of heat in the component.</p> <ol style="list-style-type: none"> 1. Mounting surface in control cabinet 2. Outgoing heated air 3. Component 4. Fan inside the component (forces the cooling air current) 5. Cooling air
G2	180° to normal mounting position
G3	90° to normal mounting position
G4	Bottom mounting; mounting surface on bottom of control cabinet
G5	Top mounting; mounting surface at top of control cabinet

Tab.5-8: Mounting Positions

Mounting Positions of Motor-Integrated Servo Drives

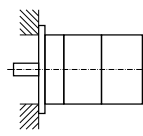
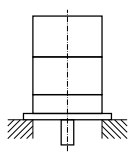
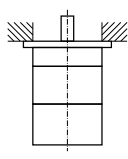
IM B5	IM V1	IM V3
		
<p>Flange mounting on drive side of flange</p> <p>The drive electronics of a motor-integrated servo drive can be oriented as desired.</p>	<p>Flange mounting on drive side of flange, drive side bottom</p>	<p>Flange mounting on drive side of flange, drive side top</p>

Tab.5-9: Allowed Types of Installation According to EN 60034-7:1993

NOTICE

Damage caused by penetration of fluids!

If fluid is present at the output shaft over a prolonged time in mounting position IM V3, the fluid may enter the housing and cause damage.

Ensure that fluid cannot be present at the output shaft.

5.3.3 Compatibility With Foreign Matters

All Rexroth controls and drives are developed and tested according to the state-of-the-art technology.

General Data and Specifications

As it is impossible to follow the continuing development of all materials (e.g. lubricants in machine tools) which may interact with the controls and drives, it cannot be completely ruled out that any reactions with the materials we use might occur.

For this reason, before using the respective material a compatibility test has to be carried out for new lubricants, cleaning agents etc. and our housings/materials.

5.3.4 Motor Paint Coat

Color Black (RAL9005)

Resistance *Resistant to*

- Diluted acids and lyes
- Water, sea water, waste water
- Common mineral oils

In restricted form resistant to

- Organic solvents
- Hydraulic oil

Nonresistant to

- Concentrated acids/lyes

Additional paint coat **Allowed for:**

Standard products

It is permitted to provide the housing with an additional paint coat having a maximum thickness of 40 µm. Before applying the paint coat, verify the adhesion and resistance of the new coat.



When applying a paint coat subsequently, provide paint protection on all safety labels, type plates and open plug-in connectors. The functionality of the motor may not be restricted by the additional paint coat.

Not allowed for:

Products for explosive atmospheres

It is not allowed to provide motors in Ex design with additional paint coats in order to prevent negative effects on surface properties (such as insulation resistance, electrostatic charge).

5.4 Voltage Test and Insulation Resistance Test

According to standard, the **components** of the Rexroth IndraDrive range are tested with voltage.

Test	Test rate
Voltage test	100% (EN 61800-5-1)
Insulation resistance test	100% (EN 60204-1)

Tab.5-10: Applied Standards

5.5 Control Voltage (24V Supply)



PELV¹⁾ for 24V power supply unit

For the 24V supply of the devices of the Rexroth IndraDrive range, use a power supply unit or a control-power transformer with protection by PELV according to IEC 60204-1 (section 6.4).

In the scope of CSA/UL, the data of the control-power transformer are limited to:

- Max. output voltage: 42.4 V_{peak} or 30 V_{ac}
- Max. output power: 10000 VA

The data in the table below generally apply to the 24V supply of the devices of the Rexroth IndraDrive range. For other data, such as power consumption and inrush currents, see the technical data of the respective device.

The specified values apply at the connections (+24V, 0V) to the "24V supply" of the devices!

Description	Symbol	Unit	Value
Control voltage for drive systems without operation of motor holding brakes in Rexroth motors	U _{N3}	V	20,4 ... 28,8 (24 +20% -15%) When using supply units HMV01.1E, HMV01.1R, HMV02.1R, HLB01.1D: 22,8 ... 27,3 (24 -5%, 26 +5%)
Control voltage for drive systems with operation of motor holding brakes in Rexroth motors	U _{N3}	V	Depending on the motor cable length, the control voltage must be within the following voltage ranges: <ul style="list-style-type: none"> • Motor cable length < 50 m: 22,8 ... 25,2 (24 ±5%) • Motor cable length > 50 m: 24,7 ... 27,3 (26 ±5%) Take the data of the corresponding motor holding brake into account.
External control voltage at devices of design "NNNV" (see type code HCS02, HCS03; other design: DC 24 V power supply from the DC bus and external)	U _{N3}	V	26 ... 28,8 The output voltage of the internal switching power supply unit is 24 ±10%.
Max. ripple content	w	-	The amplitudes of the alternating component on U _{N3} must be within the specified voltage range.
Maximum allowed overvoltage	U _{N3max}	V	33 (max. 1 ms)

Tab.5-11: Control Voltage

1) Protective Extra Low Voltage

General Data and Specifications

Description	Symbol	Unit	Value
Control voltage for drive systems	U_{N3}	V	20,4 ... 28,8 (24 +20% -15%) When using supply units HMV01.1E, HMV01.1R, HMV02.1R, HLB01.1D: 22,8 ... 27,3 (24 -5%, 26 +5%)
Max. ripple content	w	-	The amplitudes of the alternating component on U_{N3} must be within the specified voltage range.
Maximum allowed overvoltage	U_{N3max}	V	33 (max. 1 ms)

Tab.5-12: Control Voltage

**Overvoltage**

Overvoltage greater than 33 V has to be discharged by means of the appropriate electrical equipment of the machine or installation.

This includes:

- 24V power supply units that reduce incoming overvoltage to the allowed value.
- Overvoltage limiters at the control cabinet input that limit existing overvoltage to the allowed value. This, too, applies to long 24V lines that have been run in parallel to power cables and mains cables and can absorb overvoltage by inductive or capacitive coupling.

**Insulation monitoring impossible**

The input 0 V is connected in conductive form to the housing potential. Insulation monitoring at +24 V and 0 V against housing is impossible.

6 Project Planning of Control Voltage (24V Supply)

6.1 General Information

To operate the drive system, supply the devices with control voltage. For the project planning of the 24V supply of the drive system, take the requirements of the devices used into account:

- Voltage and voltage tolerances depending on line lengths and use of holding brake.

See also [chapter 5.5 "Control Voltage \(24V Supply\)" on page 65](#)

- Power consumption of the drive controllers with control section and power section
- Power consumption of other components, e.g. holding brakes
- Current carrying capacity of the connections for "looping through"
- Buffering the control voltage supply might possibly be necessary

 For the requirements of the supply units and converters, see Project Planning Manual "Rexroth IndraDrive Supply Units and Power Sections" → Chapter of the respective device → "Technical Data" → "Basic Data" → table "Data for Control Voltage Supply".

6.2 Selecting the 24V Supply

6.2.1 General Information

The components need the 24V supply for correct operation. At components of the Rexroth IndraDrive range, the external 24V supply takes place via the connection X13 or via the connections 24V and 0V at the terminal block.

Via these connections, the components are supplied with 24V for

- the power section of the drive controller or supply unit
- brake control via X6
- the control section of the drive controller



In particular, take mains failure situations into account and use power supply units with buffer (UPS), if necessary.

The inputs/outputs of the I/O extensions MA1, MD1 and MD2 are not supplied with voltage via the control section, but have their own connections.

Take the additional power required for these connections into account.



HCS02/HCS03 converters of the **design "-N**V"** have an **integrated 24V supply**. In applications without motor holding brake and with CSB01.1N-FC control section, they can be operated without external 24V supply. Observe the notes on project planning for the mains connection.

Project Planning of Control Voltage (24V Supply)

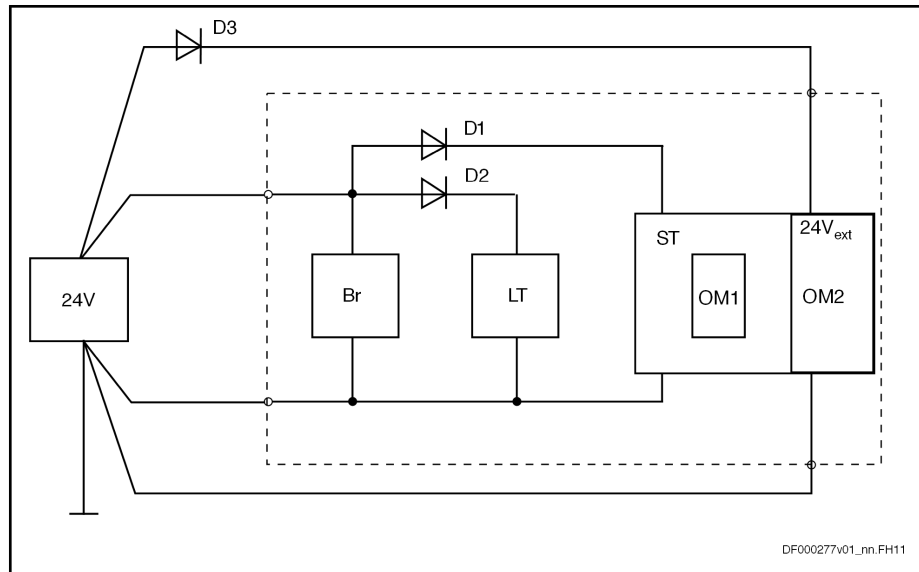

D1, D2	Diodes, internal
D3	Protective diode, external
LT	Power section
BR	Circuit motor holding brake
ST	Control section
OM1	Optional modules
OM2	Optional modules with supply voltage connection, e.g. MA1, MD2

Fig. 6-1: Block Diagram of 24V Supply

6.2.2 Electrical Requirements

The following parameters contain the essential electrical requirements on the power supply unit:

- **Output voltage** or range of output voltage
- **Continuous power** which the power supply unit must supply during operation
- **Peak current** which the power supply unit must supply when switching on

Which Output Voltage Must the Power Supply Unit Have?

The output voltage of the power supply unit must have been dimensioned such that the voltage at the input of the devices ("24V supply": 24V; 0V) is within the allowed voltage U_{N3} .



Take into account that due to voltage drops, the output voltage of the power supply unit is lower than the voltage at the devices. Check the voltage at the input of the "24V supply" of the devices.

Use power supply units

- with adjustable output voltage from 24 V to 26 V
- which have been equipped with Sense inputs (this allows compensating for the voltage drops on the line between power supply unit and input "24V supply")



See Project Planning Manual "Rexroth IndraDrive Supply Units and Power Sections" → Chapter of the respective device → "Technical Data" → "Basic Data" → "Data for Control Voltage Supply".

Project Planning of Control Voltage (24V Supply)

**Control voltage when using motor holding brakes!**

Depending on the motor cable length, a higher output voltage of the power supply unit is required for operating the motor holding brakes. Observe the data for operating motors with holding brakes (see [chapter 5.5 "Control Voltage \(24V Supply\)"](#) on page 65).

Which Continuous Power Must the Power Supply Unit Supply?

The continuous power of the power supply unit must be greater than the sum of power consumptions P_{N3} of the components to be supplied.

For the power consumption P_{N3} , see Project Planning Manual "Rexroth IndraDrive Supply Units and Power Sections" → Chapter of the respective device → "Technical Data" → "Basic Data" → "Data for Control Voltage Supply".

For the power consumption of the control sections (basic control section circuit board or optional modules), see Project Planning Manual "Rexroth IndraDrive Control Sections" → index entry "Power consumption"

If required, determine the continuous current I_{N3} for selecting the power supply unit:

$$I_{N3} = P_{N3} / U_{N3}$$

The power consumption is indicated as maximum value of the respective component and can occur at **individual components**.

In drive systems with **several components**, the occurring power consumption under statistical assumptions will be lower than the calculated one.

Experience has shown that the **typical power consumption** of drive systems is at only **approx. 70%** of the calculated maximum value.

Which Peak Current Must the Power Supply Unit Supply?

When switched on, the power supply unit must supply the sum of the occurring inrush currents I_{EIN3} or charges $I_{EIN3} \times t_{EIN3Lade}$.

When the power supply unit is switched on, the power supply unit is loaded with the charging current to the capacitors of the 24V supply input of the connected devices. An electronic circuit in each drive controller limits this charging current to the value I_{EIN3} .

For the data of the inrush current I_{EIN3} and its pulse width $t_{EIN3Lade}$ for the individual devices, see Project Planning Manual "Rexroth IndraDrive Supply Units and Power Sections" → Chapter of the respective device → "Technical Data" → "Basic Data" → "Data for Control Voltage Supply".

The occurring charging process $I_{EIN3} \times t_{EIN3Lade}$ is controlled by power supply units with **integrated dynamic current limitation**, if the power supply units allow the 1.2-fold continuous current for at least 1 second. Therefore, use power supply units with integrated dynamic current limitation the continuous power of which is at least 20% above the determined sum of power consumptions P_{N3} .

**Power supply units with buffer (UPS)**

For HMV supply units, use 24 V supplies with buffer times of at least 100 ms (e.g. UPS), if commutation drops and short-time interruptions in the application exceed the specified values.

For the 24V supply, take notes on project planning of the mains connection into account (see [chapter 7 "Project Planning of Mains Connection"](#) on page 73).

Project Planning of Control Voltage (24V Supply)

6.3 Installing the 24V Supply

As a matter of principle, the 24V supply of the devices of the drive system Rexroth IndraDrive has to be designed in star-shaped form, i.e. for each group of drive controllers or third-party components it is necessary to run separate supply lines. This, too, applies to multiple-line arrangement in the case of supply from a supply unit, for example.

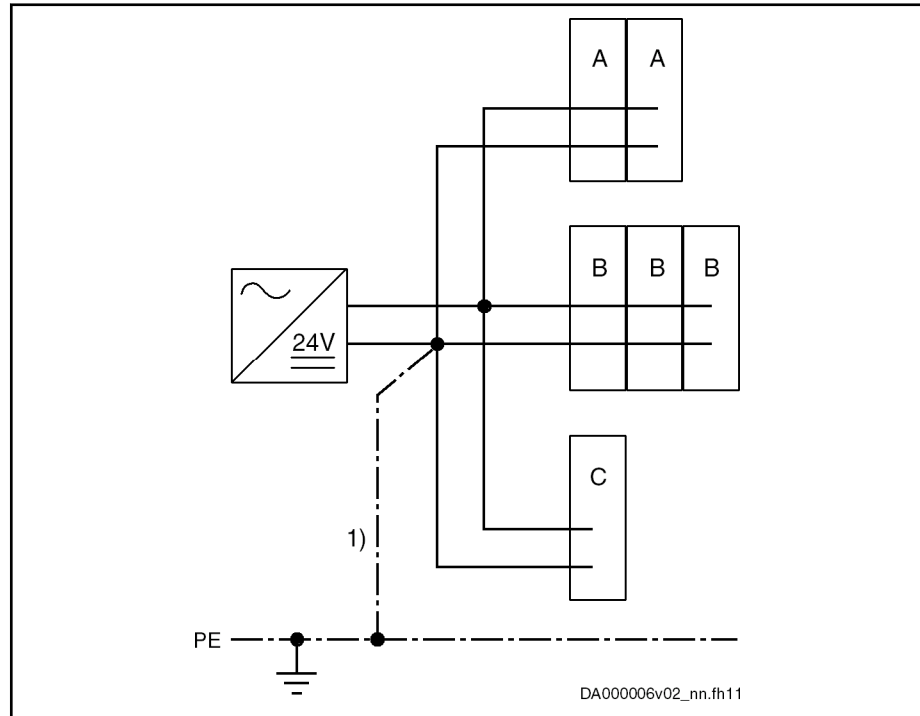

- A Device group, e.g. IndraDrive C
 B Device group, e.g. IndraDrive M
 C Third-party component (e.g. PLC, valve etc.)
 1) Connection to central ground point (e.g. earth-circuit connector)

Fig. 6-2: Installing the 24V Supply



If you use several power supply units for 24 V supply:

- Interconnect reference conductors 0 V of the individual power supply units with low impedance
- The output voltages of the power supply units must be within the allowed voltage range.
- Switch the power supply units on and off synchronously.

Reduce load-dependent voltage drops by using lines with sufficiently dimensioned line cross sections.

Chronological Order of 24V Supply and Mains Voltage

Before mains voltage or DC bus voltage is applied to the devices, they have to be supplied by the 24V supply.

In this context, observe the chapter [9 Circuits for the Mains Connection](#), page 141.

6.4 Looping Through the Control Voltage Supply

NOTICE

Property damage in case of error caused by too small line cross section!

Make use of the contact bars provided to loop-through and observe the current carrying capacity of the connections for 24V supply at the devices used (see Project Planning Manual "Rexroth IndraDrive Supply Units and Power Sections" → "Terminal Block, 24 - 0V (24V Supply)" and "X13, Control Voltage").

At the drive controllers, the 24V supply is looped through via contact bars from one device to the next (for HCS02, HLB01.1C and HLC01.1C via lines at X13).

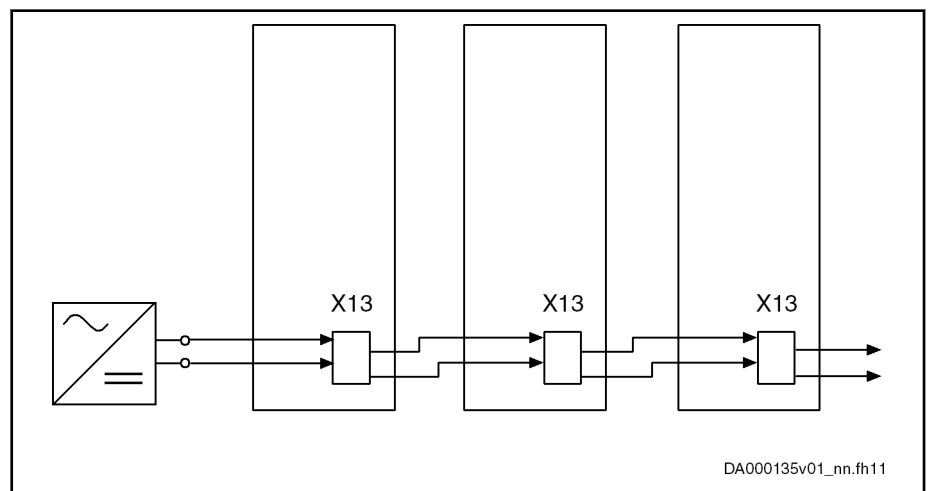

Fig. 6-3: Looping Through the Control Voltage, Example HCS02.1E-W0012

Exemplary calculation for 3 drive controllers:

$$I_D = 3 \times \frac{P_{N3}}{U_{N3}}$$

Fig. 6-4: Continuous Current

The result I_D must be smaller than the specified current carrying capacity of the connection point.



Looping through at HCS02

The current carrying capacity of X13 at HCS02 is only suited for looping through low currents. Limit the looping through to loads with low power consumption, such as HCS02.1E-W0012 with CSB01.1N-FC and additional components HLB01.1C.



Inrush current I_{EIN}

When connecting the control voltage source to the connection point for 24V supply, a higher inrush current I_{EIN} will flow for the specified duration $t_{EIN3Lade}$.

The inrush current is increased with every additional drive controller.

7 Project Planning of Mains Connection

7.1 General Information

To supply the drive system with power, it is connected to the local supply mains via the mains connection. For the project planning of the mains connection, observe the requirements of the supply mains and of the devices used.

The essential requirements are:

- Mains voltage U_{LN} (depending on mains type) with mains frequency f_{LN} , number of phases and rotary field
- Mains connected load S_{LN} , mains short-circuit power S_{k_min} and system impedance
- Short-circuit current I_{SCCR} , particularly when used in the scope of C-UL
- Mains circuit breakers and mains contactor
- Protection systems that can be used, such as residual-current-operated circuit-breakers and insulation monitoring devices

7.2 Mains Voltage Supply



Permanent mains connection

A permanent connection to the supply mains is required for Rexroth IndraDrive controllers.



Make sure that **all** components participating in the mains connection are operated in their allowed voltage ranges.

Description	Symbol	Unit	Value of the respective component
Short circuit current rating (UL)	SCCR	A rms	See chapter 7.4.2 "Mains Short-Circuit Power" on page 80
Nominal mains voltage	U_{LN_nenn}	V	Reference value for performance data, for example
Mains voltage single-phase	U_{LN}	V	Voltage of mains must be within the specified voltage range.
Mains voltage at TN-S, TN-C, TT mains¹⁾			Phase-to-phase voltage of mains must be within the specified voltage range; otherwise, use matching transformer .
Mains voltage at IT mains¹⁾			Phase-to-phase voltage of mains must be within the specified voltage range; otherwise, use isolating transformer with grounded neutral point .
Mains voltage at mains grounded via outer conductor¹⁾			
For the data of the individual devices, see Project Planning Manual "Rexroth IndraDrive Supply Units and Power Sections" → Chapter of the respective device → "Technical Data" → "Basic Data" → table "Data for Mains Voltage Supply".			
In TN-S, TN-C, TT, IT mains type and mains grounded via outer conductor:			
Rotary field			No rotary field condition
Allowed range of mains frequency	f_{LN}	Hz	(50...60) ±2

Project Planning of Mains Connection

Description	Symbol	Unit	Value of the respective component
Maximum allowed mains frequency change	$\Delta f_{LN} / t$	Hz/s	$2\% \times f_{LN}$
Maximum allowed voltage unbalance according to IEC 61000-2-4, class 3			3%
Maximum allowed voltage dips on the mains voltage according to IEC 60146-1-1 – class 3			40% of the mains amplitude; Voltage dip mustn't exceed $250\% \times \text{degrees}$ (see diagram "Maximum Allowed Voltage Dips in % of the Mains Voltage, page 74")
Maximum allowed THD according to IEC 61000-2-4, class 3			10%
Short-time interruptions			n.s., see section "Note on Project Planning Short-Time Interruptions, page 74"

1) Explanations: See chapter 7.3 "Mains Types" on page 76

Tab.7-1: Standard Range of Power Voltage

Allowed Voltage Dip

The curves in the figure show the relation between duration and allowed relative value of voltage dips with mains frequencies of 50 Hz and 60 Hz.

$$dt \times f_{LN} \times dU / U_{LN} \times 360^\circ \approx 250\% \times \circ$$

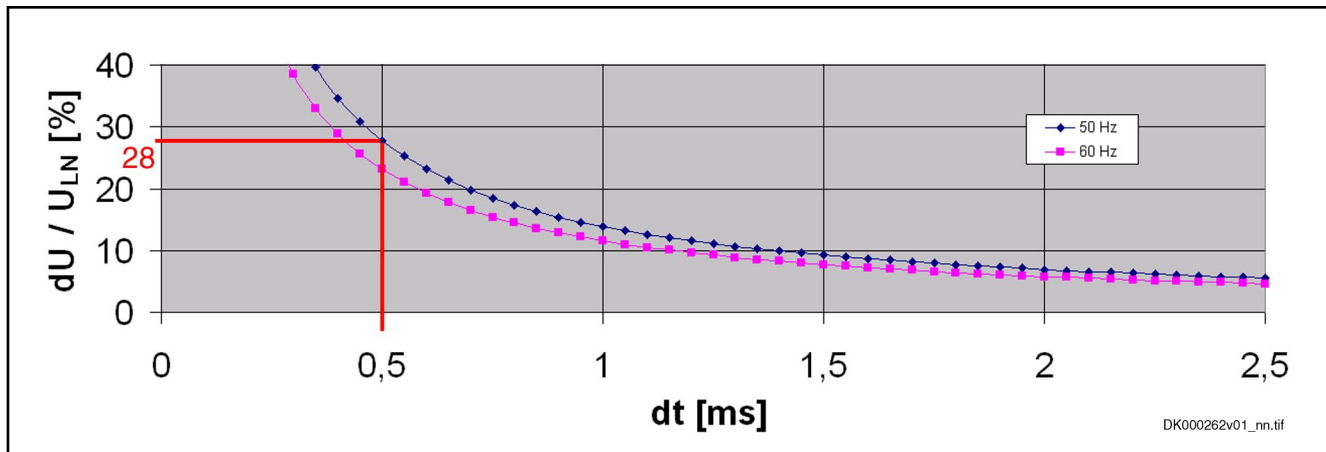

dt Duration of voltage dip

dU/U_{LN} Relative voltage dip

f_{LN} Mains frequency

U_{LN} Mains voltage

Fig.7-1: Maximum Allowed Voltage Dips in % of the Mains Voltage

How to read the example:

Mains frequency $f_{LN} = 50$ Hz and duration of voltage dip $dt = 0.5$ ms

⇒ Maximum allowed voltage dip: 28% of applied mains voltage U_{LN}

Note on Project Planning "Short-Time Interruptions"

The drive system is used for energy conversion and a voltage dip is a loss of available energy.

The effect of the voltage dip (energy reduction) on the process cannot be determined without detailed knowledge of the respective process. The effect is a system and rating aspect and generally will be greatest when the power demand (including the losses) of the drive system is greater than the available power.

Project Planning of Mains Connection

Note on Project Planning "Over-voltage Limitation"

In the case of a voltage dip on the mains, the voltage in the DC bus can be reduced. This can cause the drive system to be cut off the mains when voltage falls below certain levels and certain times are exceeded. When voltage returns, the drive system has to be reactivated in order to continue operation.

If connection to the supply mains is permanent and stationary in industrial environment (subsequent to the main distribution board), there aren't any over-voltage limiters required up to an installation altitude of 2000 m ($h_{\text{max,ohne}}$; see [chapter 5.3 "Installation Conditions" on page 58](#)). Installation altitudes of more than 2000 m to a maximum of 4000 m require overvoltage limiters between outer conductor and ground (recommended protection level: 2.5 kV).



Overvoltages at the devices can occur due to

- inductive or capacitive coupling on lines
- lightning strikes

Use overvoltage limiters at the machine or installation, when the overvoltages at the devices are greater than the maximum allowed overvoltages.

Use the overvoltage limiters at long lines of the drive system run through the building in parallel with power and mains cables.

Electrically place the overvoltage limiters as near as possible to the point of entrance of the lines at the control cabinet.

Project Planning of Mains Connection

7.3 Mains Types

7.3.1 TN-S Mains Type

The TN-S mains type is the usual mains type in Europe.

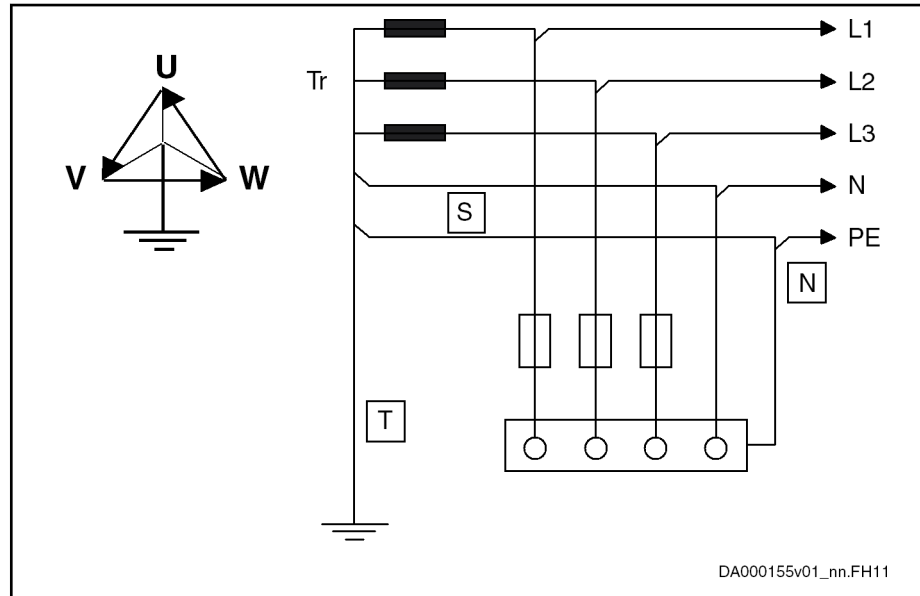

- T = Direct grounding of a point (station ground)
 N = Exposed conductive parts directly connected to station ground
 S = Separate neutral conductor and equipment grounding conductor in entire mains

Fig.7-2: TN-S Mains Type

7.3.2 TN-C Mains Type

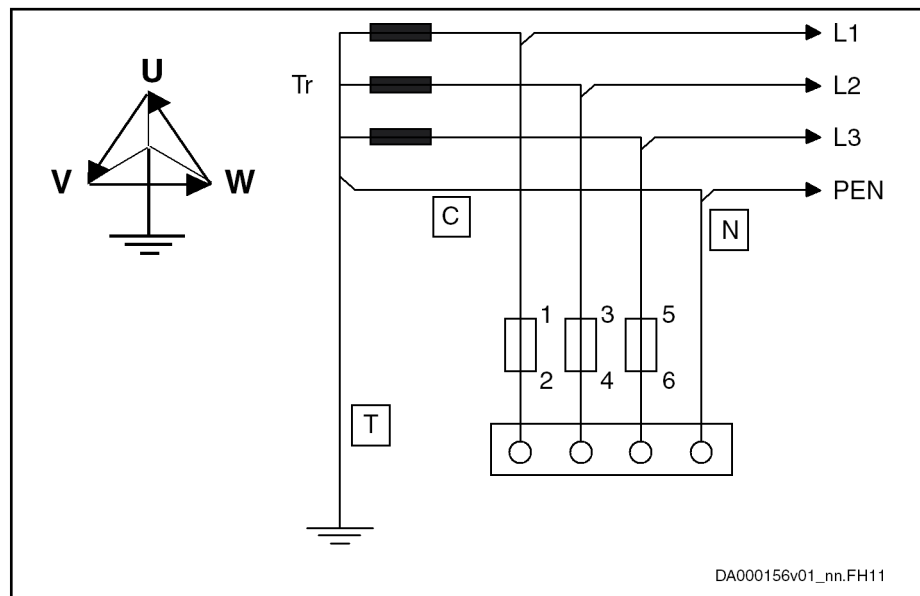

- T = Direct grounding of a point (station ground)
 N = Exposed conductive parts directly connected to station ground
 C = Neutral conductor and equipment grounding conductor functions in entire mains combined in a single conductor, the PEN conductor.

Fig.7-3: TN-C Mains Type

7.3.3 IT Mains Type

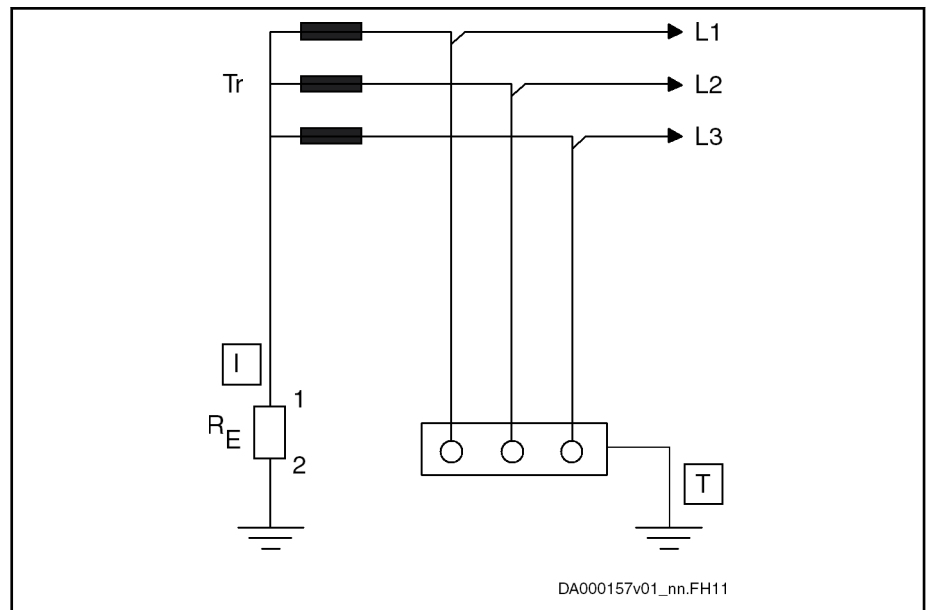

- I Isolation of all active parts from ground or connection of one point to ground via an impedance R_E
- T Exposed conductive parts directly grounded, independent of grounding of current source (station ground)

Fig.7-4: IT Mains Type

Notes on Project Planning

NOTICE

Damage to the devices by voltage arcing!

For applications with static charging (e.g. printing, packaging) and operation at IT mains type, use an **isolating transformer** with $U_K \leq 2.5\%$.



Voltage increase in the case of ground fault!

In case of the error "ground fault" in the IT mains type, higher voltages against ground (device housing) than in error-free operation affect the device.

For operation at the IT mains type, the drive system including mains filter and mains choke should be galvanically decoupled from the mains via an **isolating transformer**.

In this way, the ground fault detection or monitoring can remain effective in the installation.



HCS03 drive controllers must not be operated at IT mains types.

When operating IndraDrive C (HCS02) drive systems in other applications **without isolating transformer** at the IT mains type:

- Observe the allowed mains voltage U_{LN} at the IT mains type of the corresponding devices
- Observe the allowed switching frequency f_s ; see note below
- Check whether the ground fault detection of the mains does not trigger accidentally

Project Planning of Mains Connection

- Check whether the interference suppression (that is only activated via the parasitic mains capacitances of the ungrounded mains) is still sufficient to comply with the required limit values

The EMC requirements are only complied with by further measures (special mains filters, among other things)!

7.3.4 TT System

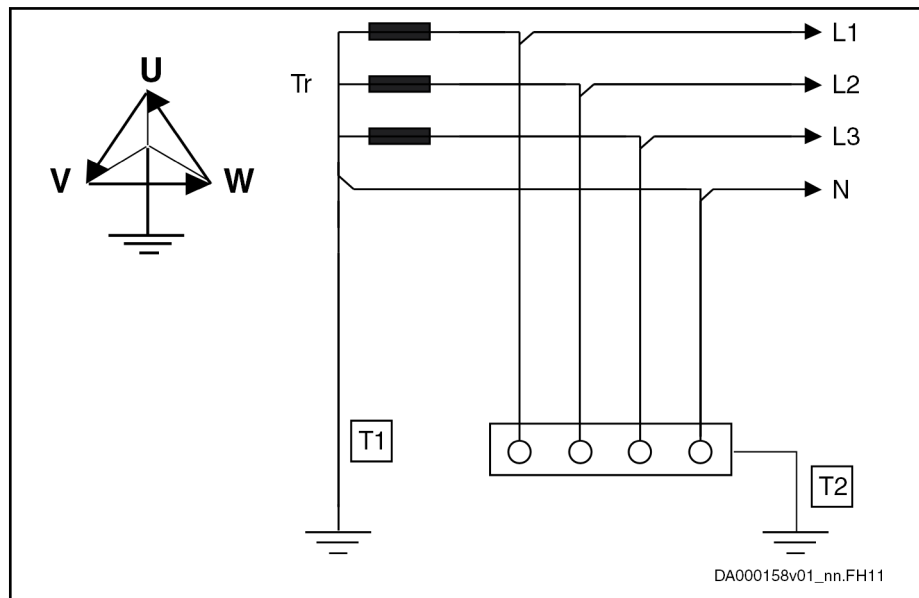

T = Direct grounding of a point (station ground)

T = Exposed conductive parts directly grounded, independent of grounding of current source (station ground)

Fig. 7-5: TT Mains System

The EMC requirements are only complied with by specific measures (special mains filters, among other things).

7.3.5 Mains Grounded via Outer Conductor (Corner-Grounded Delta Mains)

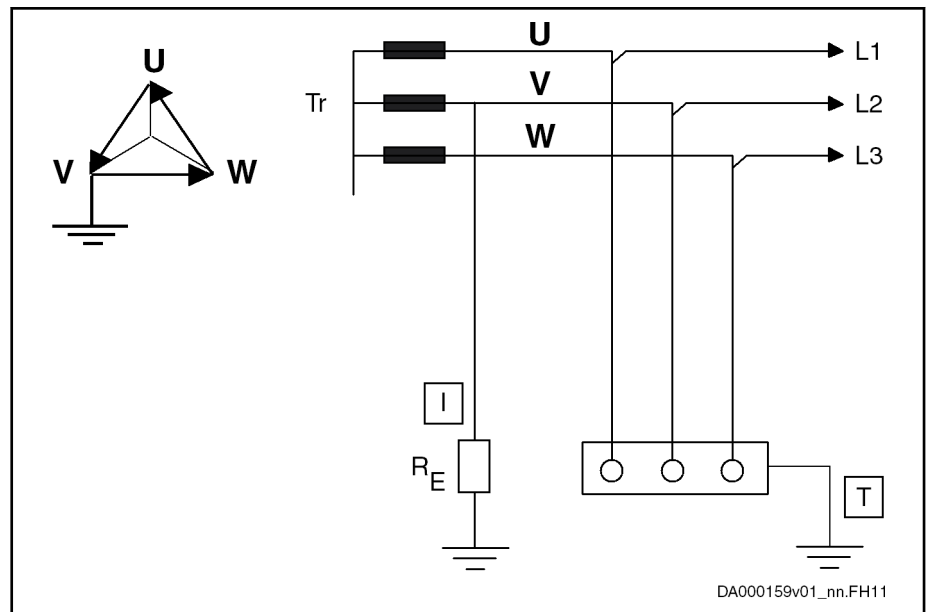

I = Isolation of all active parts from ground, connection of one phase - generally phase V - to ground or via an impedance R_E

T = Exposed conductive parts directly grounded, independent of grounding of current source (station ground)

Fig.7-6: Mains Grounded via Outer Conductor

Notes on Project Planning

The EMC requirements are only complied with by specific measures (special mains filters, among other things).



Mains filters HNF01, NFD at mains grounded via outer conductor

HNF01.1 or NFD03.1 mains filters are not suited for operation on mains grounded via outer conductor. Use isolating transformers.

Allowed mains connection voltage: See technical data of the respective device

7.4 Mains Short-Circuit Power and Mains Connected Load

7.4.1 General Information

Apart from the mains connected load, observe the following corridor of the mains short-circuit power for the mains connection:

- **Minimum required mains short-circuit power** (mains connected load) for interference-free operation

The smaller the mains short-circuit power, the greater the mains pollution due to the load current with harmonics on the supply voltage of the device. This can disturb both the device and other devices at the same mains node.

Minimum mains short-circuit power is required to limit mains pollution and to have sufficiently high voltage for realizing the drive performance.

- **Maximum allowed mains short-circuit power** (for device protection)

The higher the mains short-circuit power, the greater the short-circuit currents occurring in the case of error.

Use mains chokes to limit the short-circuit currents in the case of high mains short-circuit power S_k .

Project Planning of Mains Connection



Explanations on the short designations used: See [chapter 15.2 "Calculations for the Mains Connection"](#) on page 260

7.4.2 Mains Short-Circuit Power

Definition of Mains Short-Circuit Power

Power at nominal voltage U_N between the phases and the maximum mains short-circuit current I_k at the connection point:

$$S_k = \sqrt{3} U_N \times I_k$$

S_k Short-circuit power of the mains

I_k Short-circuit current

U_N Mains voltage

Fig.7-7: *Mains Short-Circuit Power*



For the mains short circuit power of the point of supply, ask your local power supply company.

Definition of Mains Short-Circuit Current

The mains short-circuit current I_k results in the case of a short circuit at the point of power supply connection.

$$I_k = \frac{U_N}{\sqrt{3} X_k}$$

X_k System impedance

U_N Mains voltage

Fig.7-8: *Mains Short-Circuit Current*



UL requirement "maximum short-circuit current SCCR"

In the scope of CSA/UL, devices with C-UL listing may only be operated at mains nodes with a symmetrical short-circuit current smaller than the indicated value SCCR.

For the SCCR value, see the technical data of the device.

If necessary, use mains chokes to increase the system impedance and reduce the short-circuit current.

$$SCCR = I_k$$

Mains Classes According to Short-Circuit Power

We basically distinguish mains classes graded according to mains short-circuit power and system impedance:

Classification	S_k MVA	$U_N = 400 \text{ V}$		$U_N = 480 \text{ V}$	
		X_k mOhm	L_k μH	X_k mOhm	L_k μH
		1 Rigid mains	200	0,80	2,55
	150	1,07	3,40	1,54	4,89
	100	1,60	5,09	2,30	7,33
	50	3,20	10,19	4,61	14,67

Project Planning of Mains Connection

Classification	S _k MVA	U _N = 400 V		U _N = 480 V	
		X _k mOhm	L _k µH	X _k mOhm	L _k µH
		2 Semi-rigid mains	40	4,00	12,73
	30	5,33	16,98	7,68	24,45
	20	8,00	25,46	11,52	36,67
	15	10,67	33,95	15,36	48,89
	10	16,00	50,93	23,04	73,34
	5	32,00	101,86	46,08	146,68
	4	40,00	127,32	57,60	183,35
3 Non-rigid mains	3	53,33	169,77	76,80	244,46
	2	80,00	254,65	115,20	366,69
	1	160,00	509,30	230,40	733,39
	0,6	266,67	848,83	384,00	1222,31

S_k Short-circuit power of the mains

X_k System impedance

L_k Inductance of mains phase

Tab.7-2: Mains Classified According to Mains Short Circuit Power and Mains Internal Resistance



Minimum inductance

The specified minimum inductances protect the drive controllers (especially the DC bus capacitors) during operation at mains with low impedance and high mains short-circuit power.

Use mains chokes at mains with L_k < L_{min}.

Example:

U_N = 400 V; S_k > 20 MVA; L_k = 25.46 µH

Data L_{min} of drive controller in technical data: 40 µH

L_k < L_{min}: Use of assigned mains choke is required.

7.4.3 Mains Connected Load

Definition of Mains Connected Load

The drive system loads the mains with effective power and wattless power, both together make the so-called apparent power. At the mains connection, the apparent power of the drive system is the mains connected load.

The mains connected load is calculated from the planned power in the DC bus P_{DC} and the power factor (cosφ with sinusoidal mains current and TPF with non-sinusoidal mains current):

$$S_{LN} = \frac{P_{DC}}{TPF}$$

S_{LN} Mains connected load in VA

P_{DC} DC bus continuous power in W

TPF Total Power Factor λ

Fig.7-9: Calculating the Mains Connected Load

Project Planning of Mains Connection



For the data of the TPF, see Project Planning Manual "Rexroth IndraDrive Supply Units and Power Sections" → Chapter of the respective device → "Technical Data" → "Basic Data" → table "Data for Mains Voltage Supply".

Maximum Allowed Connected Load at the Mains

The maximum allowed connected load at the mains depends on the allowed distortion of the mains voltage due to the load current with harmonics (mains pollution). The distortion is described by the total harmonic distortion (THD) of the mains current (siehe [chapter 15 "Calculations" on page 247](#)).

In order to limit the distortion of the mains voltage, take the mains short-circuit ratio R_{SC} (ratio of the source) into account:

$$R_{sc} = \frac{I_k}{I_{1N}} = \frac{S_k}{S_A} = \frac{S_k}{\sum S_{LN}}$$

- I_k Mains short-circuit current
 - I_{1N} Fundamental wave of nominal current of all loads at connection point
 - S_k Mains Short-Circuit Power
 - S_A Connected load of all electric loads at connection point (apparent power of fundamental wave)
 - $\sum S_{LN}$ Sum of mains connected loads of the supply units or converters
- Fig.7-10: Mains Short-Circuit Ratio*



The following table is used for first **estimation** of the maximum allowed connected load S_A at the point of power supply connection in low-voltage mains at known mains short-circuit power S_K . The table does not replace the described procedure "Selecting Mains Connection Components" (siehe ["Selecting Mains Connection Components" on page 84](#)).

		$R_{SC} = 250$	$R_{SC} = 200$	$R_{SC} = 100$	$R_{SC} = 50$
Classification	S_k	S_A	S_A	S_A	S_A
	MVA	kVA	kVA	kVA	kVA
1 Rigid mains	200	800	1000	2000	4000
	150	600	750	1500	3000
	100	400	500	1000	2000
	50	200	250	500	1000
2 Semi-rigid mains	40	160	200	400	800
	30	120	150	300	600
	20	80	100	200	400
	15	60	75	150	300
	10	40	50	100	200
	5	20	25	50	100
	4	16	20	40	80

Project Planning of Mains Connection

		$R_{SC} = 250$	$R_{SC} = 200$	$R_{SC} = 100$	$R_{SC} = 50$
Classification	S_k	S_A	S_A	S_A	S_A
3 Non-rigid mains	3	12	15	30	60
	2	8	10	20	40
	1	4	5	10	20
	0,6	2,40	3	6	12

R_{SC} Mains short-circuit ratio
 S_k Mains Short-Circuit Power
 S_A Connected load of all electric loads at connection point (apparent power of fundamental wave)

Tab.7-3: Maximum Allowed Connected Load

Measures for Compliance with Allowed THD or Distortion Factor

For public mains we distinguish the following mains connections:

- Mains connections with $I \leq 16 \text{ A}$ (EN 61000-3-2):
 With an $R_{SC} \geq 1000$, there normally isn't any restriction of the allowed mains current distortion (according to EN 61000-3-2).
- Mains connections with $I > 16 \text{ A}; I < 75 \text{ A}$ (EN 61000-3-12; $I > 75 \text{ A}$ not defined by any standard at present):
 The power supply company determines the restrictions. Unless there are other values available, the following data can be considered as guide values.

R_{SC}	Allowed THD of mains current	Allowed distortion factor of mains current
≥ 1000	THD > 48%	$K > 45\%$
≥ 120	THD $\leq 48\%$	$K \leq 45\%$
> 33	THD < 13%	$K < 12\%$

Tab.7-4: Allowed THD / Distortion Factor with Given R_{SC} of the Mains ($U < 600 \text{ V}$)

Measures to comply with the maximum allowed THD or distortion factor:

- Use of mains chokes
- Use of supply units with incorporated power factor correction PFC



The following fact applies to the mains choke: The higher the inductance of the mains choke, the lower the TDH / distortion factor and the mains pollution.

The THD values specified in the table below can be obtained under the following conditions:

- Supply unit operated with nominal power
- Operation with constant load
- Low degree of voltage distortion at the point of power supply connection at which the supply unit has been connected (according to EN 61000-2-4, compatibility level in accordance with class 2)

Project Planning of Mains Connection

Device type	Realizable THD of mains current	Realizable distortion factor of mains current	Supply unit or drive controller with and without mains choke	
All devices	THD \geq 50%	K \geq 60%	HMV01.1E HMV02.1E HCS03.1 HCS02.1	Without
Devices with mains choke	THD < 48%	K < 45%	HMV01.1E HCS03.1 HCS02.1	HNL01.1
Devices with Power Factor Control (PFC)	THD < 13%	K < 12%	HMV01.1R HMV02.1R	HNL01.1 HNL02.1

Tab.7-5: Realizable THD / Distortion Factor for Drive Controllers



The allowed distortion factors can be achieved with the indicated combinations of drive controller and mains choke.



Observe the assignment of mains choke to drive controller in the Project Planning Manual "Rexroth IndraDrive Supply Units and Power Sections" → Chapter of the respective device → "Technical Data" → "Basic Data" → table "Data for Mains Voltage Supply".

For detailed information on the emitted harmonics, see this Project Planning Manual in the chapter [15.2.3 Calculations for the Mains Harmonics](#), page 261.

Selecting Mains Connection Components

Procedure for selecting the required mains supply units and, if necessary, mains choke:

1. Determine maximum current of mains connection at place of destination of application.
2. Determine mains short-circuit power S_k of mains at place of destination of application (ask power supply company).
3. Determine sum of connected loads S_A .
4. Determine ratio R_{SC} .
5. Read allowed THD or distortion factor K of mains current at place of destination of application from table "Allowed THD...".
6. Select appropriate mains supply unit and mains choke HNL from table "Realizable THD...".

7.5 Protection Systems at the Mains Connection

7.5.1 General Information

Protection against contact always depends on the kind and structure of the supply mains and the mains conditions. For project planning of an installation, the typical behavior of the devices and supply mains should always be taken into account.

For protection against contact (indirect contact) in a machine or plant in which a drive system is used, the overcurrent protective device normally used is one with protective grounding according to IEC 364 and EN 50178 (Electron-

Project Planning of Mains Connection

ic equipment for use in power installations). This is also specified in UL 508C (Industrial Control Equipment) for North America. Housing cover or encapsulation by closed housing is used as protection against direct contact with live conductors.

7.5.2 Protective Grounding

General Information

⚠ CAUTION

High contact voltage in case of error caused by too long disconnecting time of mains circuit breaker!

Select the mains circuit breaker such that the disconnecting time in the case of error (short circuit or ground fault) is shorter than 5 s according to EN 60204-1 (Annex A.1).

Keep the fault loop impedance¹⁾ of the electrical equipment (machine, installation) as low as possible so that, in the case of error, the circuit breaker can trigger within the specified disconnecting time.

Overcurrent protection normally is realized in the form of fuses or overcurrent release devices (circuit breakers, motor circuit breakers) installed at the mains connection. For details see figure.

Overcurrent protection generally is sized or set with a release current of $1.3 \times$ nominal current of the loads connected to this connection point.

In the case of an insulation error or a connection between mains phase and device housing connected to the equipment grounding conductor, the drive is disconnected from the mains.



For dimensioning the fuses, comply with these data: See [chapter 15.3.4 "Mains Contactor and Fusing "](#) on page 265

¹⁾ **Fault loop impedance** is the cumulative impedance from the current source via the active conductors to the fault location and back to the current source via the equipment grounding conductor (see EN 60204-1, Annex A.2). The fault loop impedance must be determined either by means of calculation or by means of measurement. Line lengths and the line cross sections have an influence on the fault loop impedance.

Project Planning of Mains Connection

Fusing by Protective Grounding in TN-S Mains

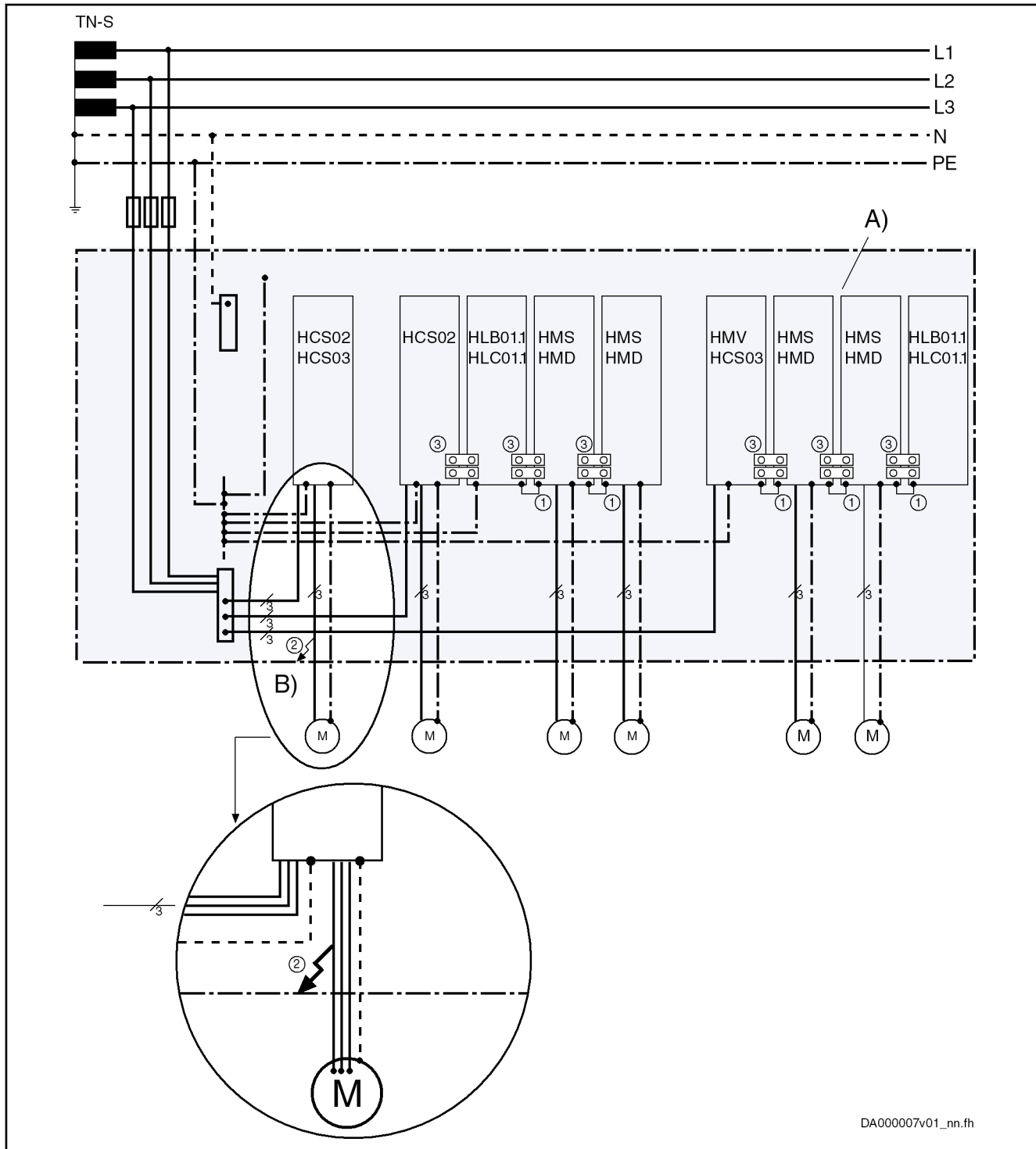

- A) Control cabinet
 B) Error
 ① Joint bar equipment grounding conductor
 ② Aim of protective measures: Contact voltage < 50 V at housing
 ③ DC bus connection L+/L-

Fig.7-11:

Protection Against Contact by Protective Grounding with Overcurrent Protection Device in TN-S Mains

Fusing by Protective Grounding in TN-C Mains

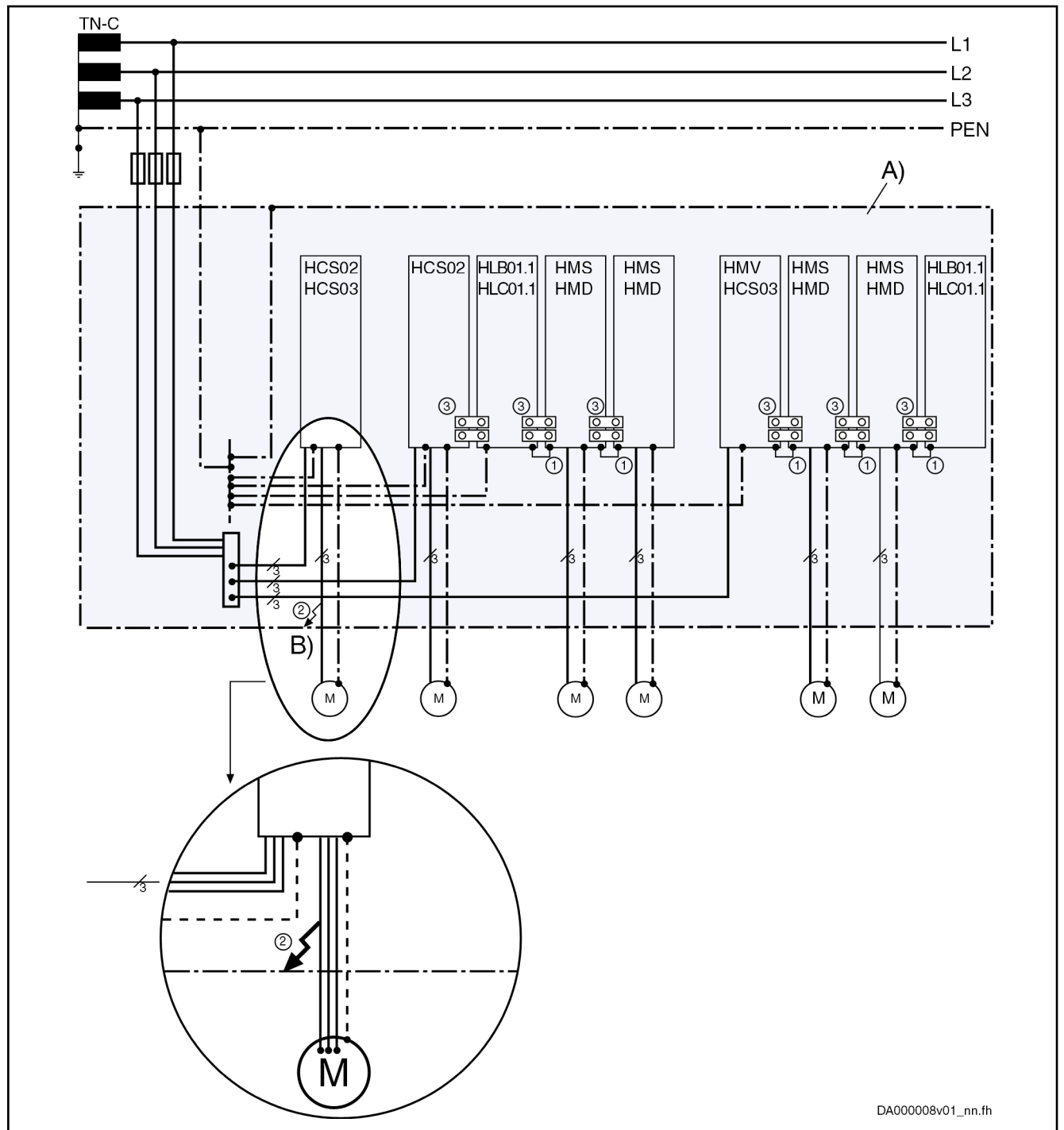

DA000008v01_nn.fh

- A) Control cabinet
 - B) Error
 - ① Joint bar equipment grounding conductor
 - ② Aim of protective measures: Contact voltage < 50 V at housing
 - ③ DC bus connection L+/L-
- Fig.7-12: Protection Against Contact by Overcurrent Protection Device in TN-C Mains

Project Planning of Mains Connection

Fusing by Protective Grounding in IT Mains (Ungrounded Mains)

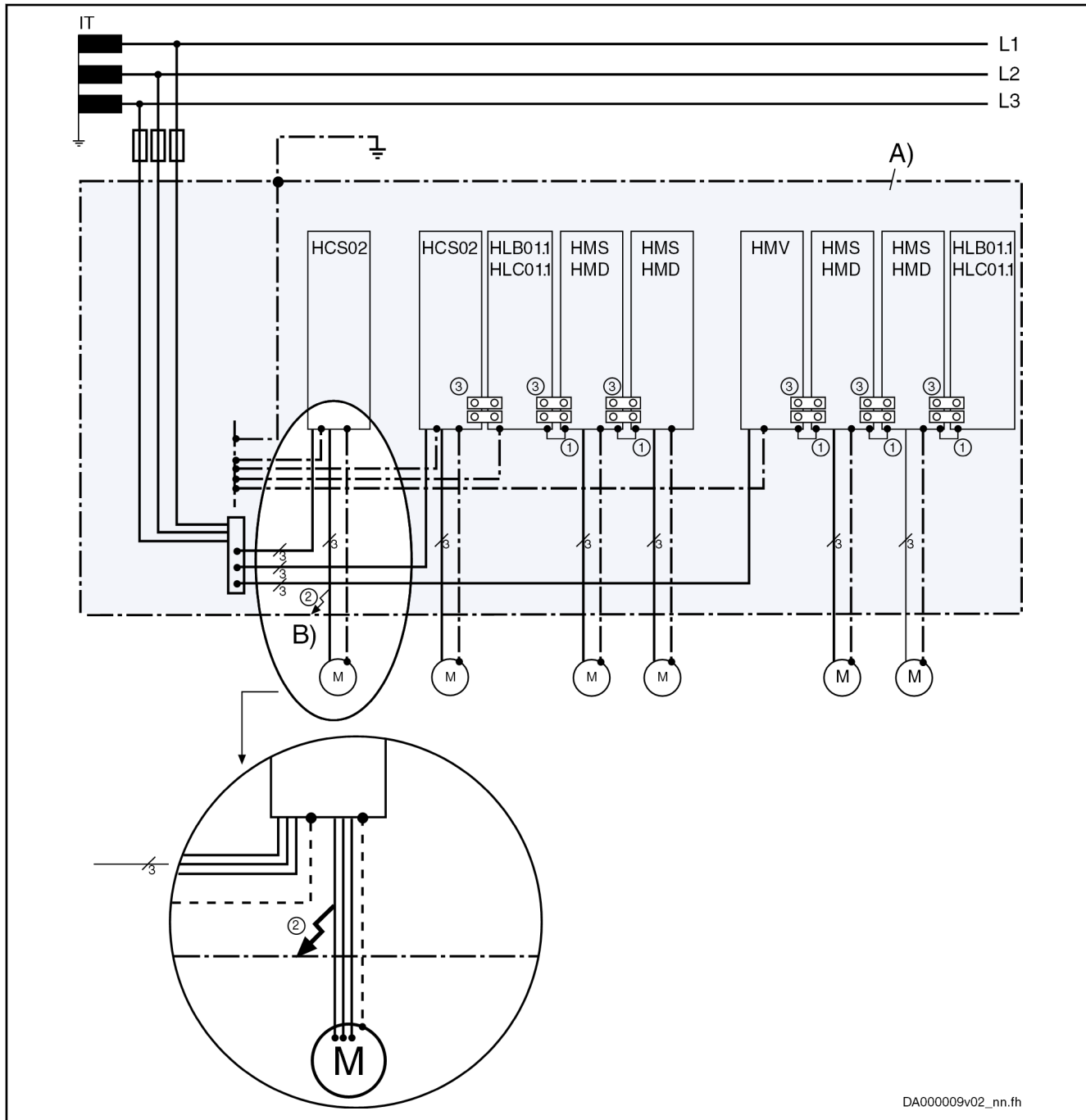

A) Control cabinet

B) Error

① Joint bar equipment grounding conductor

② Aim of protective measures: Contact voltage < 50 V at housing

③ DC bus connection L+/L-

Fig. 7-13: Protection Against Contact by Overcurrent Protection Device in IT Mains

7.5.3 Connection for the Equipment Grounding Conductor

General Information

WARNING

Lethal electric shock when touching the housing caused by faulty connection of equipment grounding conductor!

Observe the mentioned notes on installation in any case, in order to exclude danger by electric shock when touching the housing, even in case an equipment grounding conductor connection is broken.

Equipment Grounding Connection Between the Components

Observe the notes on installation.

Siehe [chapter 13.1.4 "Connection Point of Equipment Grounding Conductor and Equipment Grounding Connections"](#) on page 223).

Connecting Equipment Grounding Conductor to Mains

According to the standards "Electronic equipment for use in power installations" (EN50178, chapter 5.3.2.1) and "Adjustable speed electrical power drive systems" (EN 61800-5-1, chapter 4.2.5.4.2), a **stationary connection** of the equipment grounding conductor is required and one or more of the following requirements have to be complied with:

- Cross section of equipment grounding conductor at least 10 mm (reason: sufficient mechanical stability required)
- Mains and current supply automatically cut off when equipment grounding conductor interrupted (case of error)
- Routing of a second equipment grounding conductor, via separate terminal connectors, with the same cross section as the first equipment grounding conductor. Mounting of an additional terminal connector for this equipment grounding conductor.

7.5.4 Residual-Current-Operated Circuit Breakers (RCD, RCCB) as Additional Fusing

General Information

The following designations are used for residual-current-operated circuit breakers:

- RCCB (Residual-Current-Operated Circuit Breaker)
- RCD (Residual-Current-Operated Device)
- RCM (Residual-Current Monitoring Device)
- Earth-leakage circuit breaker (voltage-independent)
- Residual-current circuit breaker (voltage-dependent)



It is only to a limited extent that residual-current-operated circuit breakers can be used with Rexroth IndraDrive systems.

If these circuit breakers are to be used, the company erecting the installation has to check the mutual compatibility of the residual-current-operated circuit breakers and installation or machine with the drive system, in order to avoid accidental triggering of the residual-current-operated circuit breaker. This has to be taken into account

Project Planning of Mains Connection

- for switch-on processes, due to high asymmetric inrush currents and
- during operation of the installation, due to leakage currents produced in normal operation.

Cause of Leakage Currents

For the purpose of stepless speed variation with a high degree of positioning accuracy and dynamic response, certain modulation procedures are necessary for drive systems. For physical reasons, these modulation procedures give rise to inevitable leakage current produced during normal operation. Especially with unbalanced loads of the mains phases or a large number of drives it can easily reach some amperes (rms value).

The leakage current is not sinusoidal but pulse-shaped. For this reason, measuring instruments normally sized for alternating currents in the range of 50 Hz are not suited. Use measuring instruments with rms value measuring ranges up to at least 150 kHz.

The degree of leakage current depends on the following features of the installation:

- Kind of inrush current limitation
- Number, kind and size drives used
- Length and cross section of connected motor power cables
- Grounding conditions of the mains at the site of installation
- Unbalance of the three-phase system
- Kind of filters and chokes connected in the incoming circuit
- EMC measures that are taken

If measures are taken to improve the electromagnetic compatibility (EMC) of the installation (mains filters, shielded lines), the leakage current in the ground wire is inevitably increased, especially when switching on or in the case of mains unbalance. Given these operating conditions, residual-current-operated circuit breakers can trigger without an error having occurred.

The EMC measures are mainly based on capacitive short-circuiting of the interference currents within the drive system. Inductive filter measures can reduce the leakage currents, but affect the dynamic response of the drive and bring about

- higher construction volume
- higher weight
- expensive core material

Possibilities of Use

Motor Cable Length

Keep the motor cables as short as possible. Only short motor cables do allow low leakage currents and thereby enable residual-current-operated circuit breakers to work.

Kinds of Residual-Current-Operated Circuit Breakers

There are two kinds of residual-current-operated circuit breakers:

1. **Residual-current-operated circuit breakers sensitive to power pulse current** (type A acc. to IEC 60755)

These are normally used. However, it is only pulsating direct fault currents of a maximum of 5 mA and sinusoidal alternating fault currents that they switch off safely. This is why they are not allowed for devices that can generate smoothed direct fault currents. In the case of smoothed direct fault currents that can be produced in power supply units, mains rectifiers and drive controllers with power converters in B6 circuit,

Project Planning of Mains Connection

the residual-current-operated circuit breaker is not triggered. This blocks the triggering of a residual-current-operated circuit breaker sensitive to power pulse current in the case of ground contact, i.e. in the case of error.

Residual-current-operated circuit breakers sensitive to power pulse current do not provide any protection against inadmissible contact voltage.

2. Residual-current-operated circuit breakers sensitive to universal current (type B acc. to IEC 60755)

These circuit breakers are suited for smoothed direct fault currents, too, and safely switch off devices with B6 input rectifiers.

When a current with 30 mA triggers the residual-current-operated circuit breaker, it is possible to use a residual-current-operated circuit breaker with higher tripping current for machine protection.

If this residual-current-operated circuit breaker triggers accidentally, too, check in how far the above conditions and dependencies can be improved (for example, by connecting current-compensated mains chokes in the incoming circuit, increasing the inrush current limitation).

Using Isolating Transformer to Reduce Leakage Current in Mains

If there is no improvement achieved and the residual-current-operated circuit breaker, due to specific mains conditions on site, has to be used nevertheless on the mains input side, connect an isolating transformer between mains connection and power connection of the drive system. This reduces the leakage current in the ground wire of the mains that is produced during normal operation which allows using the residual-current-operated circuit breaker. Connect the neutral point of the secondary winding of the isolating transformer to the equipment grounding conductor of the drive system.

Adjust the ground-fault loop impedance to the overcurrent protective device so that the unit can be switched off in the case of failure.

Before operating enable, check the correct function of the overcurrent protection device including activation in the case of failure.

Exclusive fusing by residual-current-operated circuit breaker

For drive systems with electronic drive controllers, exclusive protection by means of a residual-current-operated circuit breaker normally is not possible and not allowed.

Electronic equipment that has a nominal power higher than 4 kVA or is destined for permanent connection does not need residual-current-operated circuit breakers.

According to IEC 364 and EN 50178, the supply-side protection against contact for indirect contact, i.e. in the case of insulation failure, has to be provided in a different way, for example by means of overcurrent protective device, protective grounding, protective-conductor system, protective separation or total insulation.

Using Residual-Current-Operated Circuit Breakers at HCS Drive Controllers

HCS Drive Controllers at Residual-Current-Operated Circuit Breaker

Residual-current-operated circuit breakers can be used under the following conditions:

- Residual-current-operated circuit breaker is of type B (IEC60755)
- Trip limit of the residual-current circuit breaker is ≥ 300 mA
- Supplying TN-S mains
- Maximum length of motor cable 20 m in shielded design
- Use of an HNF01 or NFD03 mains filter

Project Planning of Mains Connection

- Each residual-current-operated circuit breaker only supplies one drive controller
- Only Rexroth components and accessories including cables and filters are used

Using Residual-Current-Operated Circuit Breakers at HMV Supply Units

HMV01.1R, HMV02.1R at Residual-Current-Operated Circuit Breaker

Due to their function, regenerative HMV0x.1R supply units are unsuitable for the use of residual-current-operated circuit breakers.

7.5.5 Insulation Monitoring Devices

Insulation monitoring devices are normally used in IT mains with insulated neutral point. The aim is to have a monitor triggered in the case of ground fault – which means in the case of error – without having to switch off the electrical equipment.

When the monitor signals an error, the ground fault is detected and removed without operation being interrupted. Switch-off only takes place if a second ground fault occurs before the first one has been removed.

As insulation monitoring devices also measure the ground current at the mains input of the building, too high leakage current can cause accidental false triggering.

There are the same notes on application applying as mentioned in the previous chapter [7.5 Protection Systems at the Mains Connection, page 84](#).

8 Configuring the Drive System

8.1 General Information

Within the Rexroth IndraDrive product range, it is possible to combine components of the following subranges:

- Rexroth IndraDrive C
- Rexroth IndraDrive M
- Rexroth IndraDrive Mi

You have to select:

Type of supply

- Supply units
- Converter
- Type of mains connection
- Additional component mains filter
- Other additional components for mains connection

Drive

- Motors with measuring systems
- Power sections
- Control sections with options
- Firmware for selected power sections with control section

Additional Components

- For the DC bus
- For the motor output

Cables

- For power supply to the motor
- For signal evaluation from motor to control electronics

8.2 Type of Supply for Power Sections

8.2.1 General Information

The requirements to the individual axes are known from the drive task and the appropriate drive controllers - the drive system - have been selected for this purpose. For this drive system, select the appropriate supply. The following list will be explained in detail in this chapter:

- Supply by **HMV** supply unit
 - In central supply
 - In parallel operation
- Supply by **HCS** converter
 - In central supply
 - In parallel operation
- Supply by **third-party supply units**
 - **RD500 - SFT** converter

Configuring the Drive System

**Supply of IndraDrive components**

In the scope of UL, it is exclusively the following supply units which have been approved for supplying IndraDrive components HMS, HMD and KCU:

- HMV01.1R
- HMV01.1E
- HMV02.1R
- HCS02.1E
- HCS03.1E



For the project planning of HMS and HMD inverters at HCS converters, take the following aspects into account for use in the scope of UL:

- The maximum output voltage (U_{DC}) of the supplying device (e.g. HCS) must be smaller than the allowed input voltage of the inverter (e.g. HMS).
- The symmetrical nominal short-circuit current at the mains connection (I_{SCCR}) of the supplying device (e.g. HCS) must be smaller than the symmetrical nominal short-circuit current specified for the inverter (e.g. HMS).

NOTICE

Property damage caused by operation of combinations which are not allowed!

Only operate the listed, allowed combinations.

Operating components not mentioned in this documentation at the common DC bus with Rexroth IndraDrive components requires Rexroth's explicit confirmation.

Supply unit / converter	Inverter			Converter		
	HMS01	HMS02.1 N	HMD01	HCS02	HCS03	KCU01 KCU02
		-W				
HMV01.1E-W	■	-	■	-	-	■ 3)
HMV01.1R-W	■	-	■	-	-	■ 3)
HMV02.1R-W	-	■	-	-	-	■
HCS02.1E-W0054, -W0070	■ 3)	■ 1)	■ 3)	■	-	■ 2)
HCS03.1E	■	-	■	-	■	■ 3)

■ Allowed

- Not allowed

1) Do not operate HMS02 at the same DC bus with HMS01/HMD01

2) Additional capacitances at the DC bus required

3) Different mounting depths: Control cabinet adapter HAS03 required

Tab.8-1: *Supply Units for Power Sections and Motor-Integrated / Near Motor Servo Drives*



KCU at HMV and HCS - number of axes, capacitances C_y

The drive connection box KCU passes the DC bus voltage of the supply unit to the KSM/KMS via the hybrid cable. Due to decoupling components, KCU with the maximum number of KSM/KMS acts like **one more** axis with higher C_y (capacitance against ground) for HMV01.1E, HMV02.1E supply units and HCS converters.

When selecting the supply unit or converter, observe the allowed combinations of HNF/NFD mains filter and HNL mains choke.

See [chapter 8.3 "Mains Connection Supply Units and Converters"](#) on page 106

Notes on Project Planning for Number of Axes, C_y

Converters and supply units can supply inverters at their DC buses.

Detailed combinations of HCS converter, mains filter, mains choke:

See [chapter 8.3.3 "Mains Connection for HCS Converters"](#) on page 113

Detailed combinations of HMV supply unit, mains filter, mains choke:

See [chapter 8.3.2 "Mains Connection of HMV Supply Units"](#) on page 109

In the tables, observe the value C_y (capacitance against housing) in the "Explanation" column. This value limits the number of inverters (number of axes).

Orientation Guide for Selecting the Type of Supply

Criterion	HMV supply unit		HCS converter	
	Central supply with HMVxx.x	Parallel operation with HMVxx.xE (not W0030)	Central supply	Parallel operation
Number of axes = 1	■	□	■	-
Number of axes ≤ 6 $C_y \leq 2 \times 600 \text{ nF}$	■	□	■	■
Number of axes ≤ 18 with mains filter "F240" $C_y \leq 2 \times 1225 \text{ nF}$	■	□	□	□
Number of axes ≤ 40 with mains filter "M900" $C_y \leq 2 \times 2040 \text{ nF}$	■	■	-	-
High overload ratio	■	■	□	□
Regenerative operation with great energy contents	■ HMVxx.xR	□	□	□

Configuring the Drive System

Criterion	HMV supply unit		HCS converter	
	Central supply with HMVxx.x	Parallel operation with HMVxx.xE (not W0030)	Central supply	Parallel operation
High kinetic energies in the case of mains failure	□ Additionally use HLR braking resistors			
Single-phase operation	-	-	□ Only HCS02	-

- Recommended
- Allowed
- Not allowed

Tab.8-2: Orientation Guide

8.2.2 HMV Supply Units for HMS/HMD Power Sections

Central Supply HMV

Brief Description

The mains connection "central supply" (individual supply) is the standard type of connection for HMV. The "central supply" is characterized by one mains connection (mains circuit breaker, mains transformer, mains filter, mains choke) for the drive system. Other drive controllers and additional components are connected to the supply unit.

Block Diagram

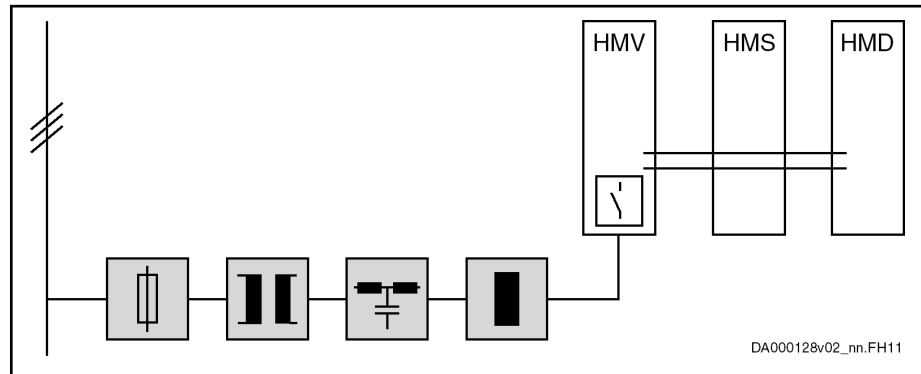

HMVxx.xE Components marked with gray background color: Optional, depending on the application

HMVxx.xR Mains filter and mains choke; necessary

HMVxx.xR-W0120 Mains filter, mains choke, external mains contactor; necessary

Fig.8-1: Central Supply HMV

The "group supply without DC bus connection of the groups" has to be handled like individual supply for HMV.

Configuring the Drive System

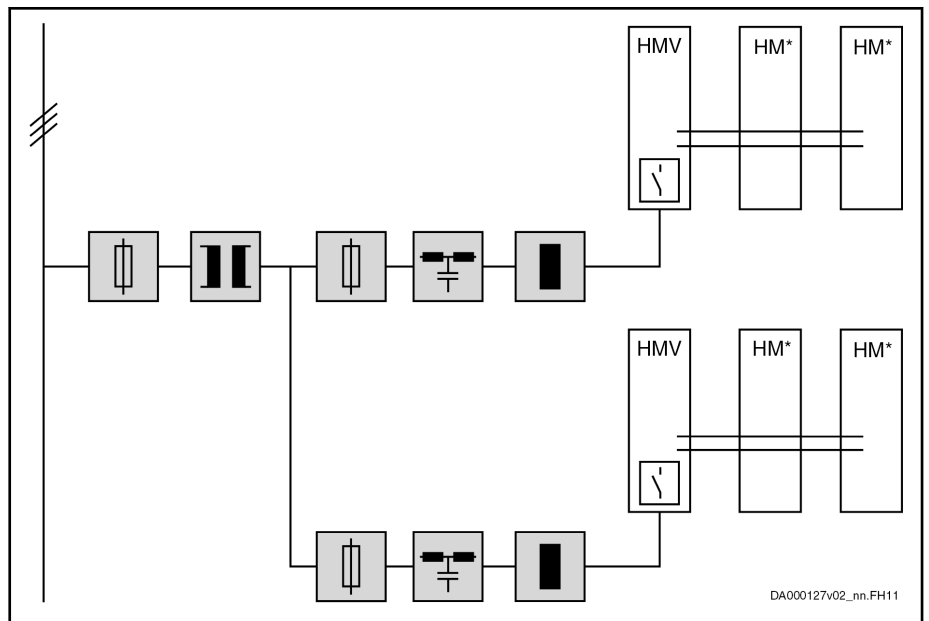

HMVxx.xE Components marked with gray background color: Optional, depending on the application

HMVxx.xR Mains filter and mains choke: necessary

HMVxx.xR-W0120 Mains filter, mains choke, external mains contactor: necessary

Fig. 8-2: Group Supply HMV Without DC bus Connection of the Groups



When **dimensioning the fuses** in the supply feeder and in branches, make sure to provide protection against overcurrent and overload in the case of error.

See [chapter 15.3.5 "Dimensioning the Line Cross Sections and Fuses"](#) on page 266

Notes on Project Planning

The maximum allowed **number of devices** at the common DC bus is limited by the ability of HMV to charge capacitances against housing (C_y).

Use more HMVs, if the determined capacitance C_y exceeds the maximum allowed value.

NOTICE

Damage to the supply unit!

Do not exceed allowed peak and continuous powers in the DC bus.

Comply with minimum value of mean phase control factor $\bar{\alpha}$ (see data of continuous power of supply unit in the technical data, calculation see [chapter 15 Calculations, page 247](#)), in order to avoid overload of the integrated DC bus capacitors by wattless currents.

High load due to wattless current is generated, when, for example, synchronous motors permanently deliver high torque at low speed or asynchronous motors are operated with high magnetization currents.

In these cases of operation, use additional capacitances at the DC bus.

Smart Energy Mode

Regenerative supply units of the HMV0x.1R-W0***-A-07-FNN2 design (Smart Energy Mode) reduce current and power peaks on the mains side. The Smart Energy Mode limits the maximum device current to the 1.1-fold value of the nominal current.

Configuring the Drive System

For the project planning of a drive system with Smart Energy Mode, there is a separate documentation. Write an e-mail to drivesupport@boschrexroth.de, if you need this documentation (Indrv_HMV0xR_Smart_Energy_Mode_xx.pdf).

Parallel Operation HMV - Group Supply with DC Bus Connection HMV01, HMV02

Brief Description

"Group supply with DC bus connection" increases the available regenerative power, the continuous braking resistor and infeeding power in the common DC bus of several drive controllers.

This mains connection is mainly used to cover the power range above the biggest modular supply unit.

Block Diagram

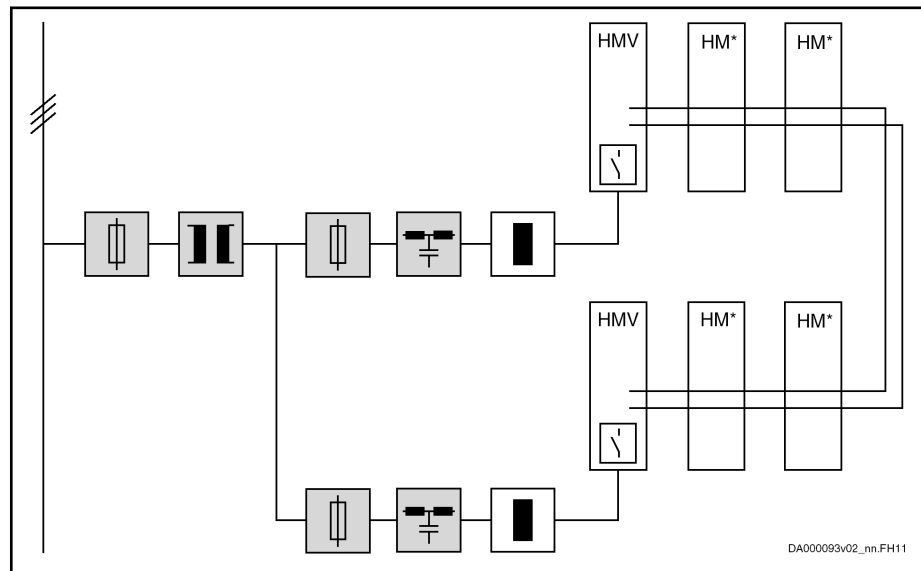

HMVxx.xE Components marked with gray background color: Optional, depending on the application

HMVxx.xR Mains filter and mains choke: necessary

HMVxx.xR-W0120 Mains filter, mains choke, external mains contactor: necessary

Fig.8-3: Parallel Operation - Group Supply HMV With DC bus Connection



When **dimensioning the fuses** in the supply feeder and in branches, make sure to provide protection against overcurrent and overload in the case of error.

See [chapter 15.3.5 "Dimensioning the Line Cross Sections and Fuses "](#) on page 266

Notes on Project Planning



Parallel operation of regenerative supply units **HMV0x.xR is not allowed!**

Supply unit	Supply units at DC bus
HMV01.1E-W0030	Two of the same type
HMV01.1E-W0075	
HMV01.1E-W0120	

Configuring the Drive System

Supply unit	Supply units at DC bus
HMV01.1R	Parallel connection is not allowed!
HMV02.1R	

Tab.8-3: Parallel Operation HMV

For mains connection, observe the control circuit for the mains connection.

Parallel operation of HMV01 supply units

- is allowed with HMV01.1E supply units of the same **type current**
- requires a **mains choke** for each supply unit (for current sharing)
- does not increase the maximum allowed number of drive controllers or axes when operated without mains filter
- requires a control circuit master-slave; see chapter 9 [Circuits for the Mains Connection](#), page 141.

For detailed information on derating and mounting, there is the specification with document number 109-1261-4102-** (available on request).

8.2.3 Converter HCS as Supply Unit

General Information

Converters are designed for operating a single drive (see also individual supply with HCS). In particular, the power supply with the capacitors in the DC bus and the mains supply have been dimensioned with regard to operation under rated conditions of the converter. When HCS converters are used as supply units, the power of the converter (P_{DC_cont} , P_{DC_peak}) is available at the DC bus connection for its own motor output and for further drive controllers.

Operating HCS converters as supply unit causes higher load of the capacitors in the DC bus.

Additional capacitors in the DC bus reduce the additional load by distributing the current.

NOTICE

Damage to the converter!

Operation as supply unit additionally loads the converter. Observe the allowed peak power and continuous power (P_{DC_cont} , P_{DC_peak}) of the converter.

Operate additional capacitors C_{DC_ext} at the DC bus and observe the notes on project planning.

Central Supply - HCS Supply HCS or HMS/HMD Drive Controllers

Brief Description

The "central supply" via HCS converters is the mains supply with which the converter supplies further drive controllers.

Configuring the Drive System

Block Diagram

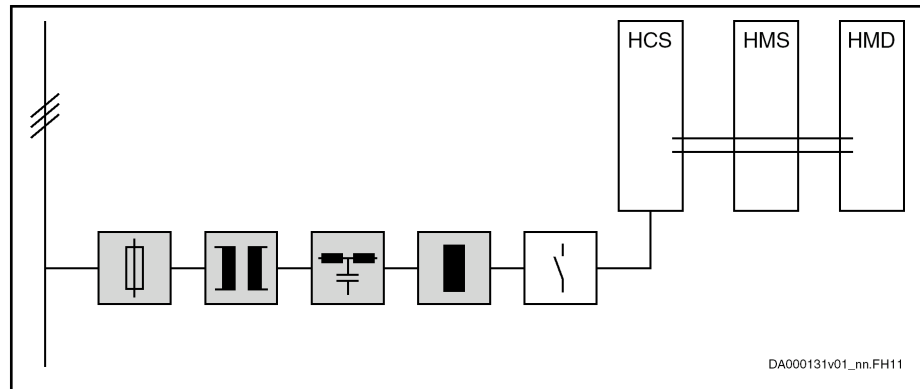

Components marked with gray background color: Optional, depending on the application

Fig. 8-4: Central Supply HCS



Use HNF mains filters and HNL mains chokes.

The "group supply without DC bus connection of the groups" allows using the additional components (HNL, HNF etc.) in the mains connection for several similar supplies.

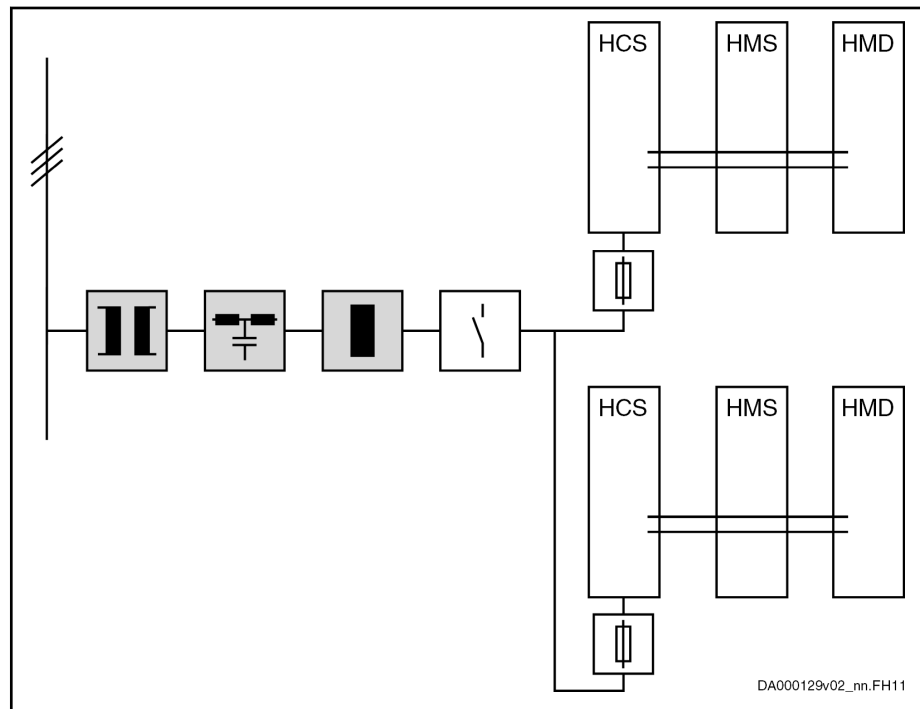

Components marked with gray background color: Optional, depending on the application

Fig. 8-5: Group Supply HCS Without Connection of the Groups



When **dimensioning the fuses** in the supply feeder and in branches, make sure to provide protection against overcurrent and overload in the case of error.

See [chapter 15.3.5 "Dimensioning the Line Cross Sections and Fuses"](#) on page 266

**Notes on Project Planning for
HCS02 as Supply Unit for
HMS/HMD**



Control the mains contactor in such a way (connect Bb contacts in series) that errors of both groups lead to circuit interruption!

The HCS02.1E-W0054 and -W0070 types are allowed as supply units.

The HCS02.1E-W0012 and -W0028 types are not allowed.

HCS02 converters as supply units for HMS/HMD require:

- Accessory **HAS03** (to adjust different mounting depths)
- Accessory **HAS04** (capacitances C_y at DC bus against ground)
- Additional capacitors C_{DC_ext} at the DC bus (external DC bus capacitance $C_{DC_{ext}}$), if
 - the arithmetical mean of the output currents I_{out} is **greater than** I_{out_cont} of the supplying device
 - the accumulated chronological sequences of the output currents I_{out} and the DC bus power P_{DC} (superposition of the individual load profiles) are **greater than** the allowed load profiles



Additional capacitance C_{DC_ext} required for HCS02!

To determine the additionally required capacitance C_{DC_ext} , the following **guide values** apply when using an HLC01.1 DC bus capacitor unit:

- HMS01: Install **10 μ F** per A type current
- HMD01: Install **20 μ F** per A type current
- HMS02: **No** additional capacitance required



Arrangement of HCS02

Place HCS02 to the left of HMS01, HMS02 or HMD01.

Place the accessory HAS04 at the left of HCS02.

Place the DC bus capacitor unit HLC01.1 at the junction from HCS02 to HMS01, HMS02 or HMD01.

**Notes on Project Planning With
HCS02 as Supply Unit for KCU02
and KSM/KMS**

The types HCS02.1E-W0054 and -W0070 are allowed as supply units for KCU02 and KSM02/KMS02.



Additional capacitance C_{DC_ext} required for HCS02!

For operation as supply unit with low load at the motor output ($P_{out} \leq 10 \% \times P_{DC_cont}$; $I_{out} \leq 10 \% \times I_{out_cont}$, where P_{out} refers to KCU02/KSM02/KMS02 and P_{DC_cont} to HCS02), the performance data is available without additional capacitance C_{DC_ext} at the DC bus.

Use additional capacitors C_{DC_ext} at the DC bus, when the load at the motor output is higher.

When you use the DC bus capacitor unit HLC01.1, the following **guide value** applies when you determine the additional capacitance C_{DC_ext} :

- **50 μ F** per kW of installed continuous power KSM/KMS, thus 700 μ F for a KCU02 operated at rated power.

Configuring the Drive System

Notes on Project Planning for HCS03

HCS03 converters as supply units for HMS01 / HMD01 require braking resistors.



Operate HCS03 with HLR!

To supply HMD01 and HMS01, operate HCS03 converters with brake chopper (option -NNBV) and HLR braking resistor.



HCS03 with external capacitors in the DC bus

External capacitors in the DC bus (e.g. HLC) can only be operated at HCS03.1E-W0210.

Thus, central supply with HCS03 is impossible.



Arrangement of HCS03

Place HCS03 to the left of HMS01 and HMD01.

Place the accessory HAS04 at the left of HCS03.

Notes on Commissioning

When converters are operated as supply units for inverters or supplied as inverters from another converter, the drive controller must be parameterized for this purpose.

For information on configuration and parameterization of the drive controllers, see Functional Description of firmware, chapter "Power Supply" and the pertinent parameters

- P-0-0860, Converter configuration
- P-0-0861, Power supply status word

Parallel Operation HCS - Group Supply with DC Bus Connection of the Groups

Brief Description

"Group supply with DC bus connection" increases the available regenerative power, the continuous braking resistor and infeeding power in the common DC bus of several drive controllers or drive systems.

Configuring the Drive System

Block Diagram

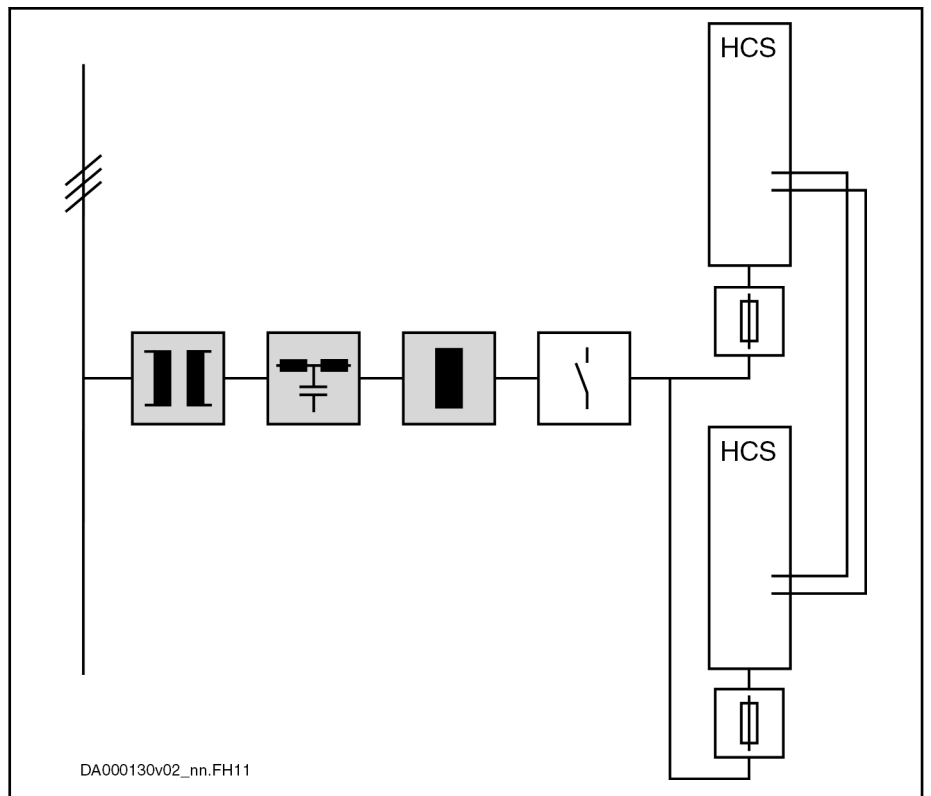

Components marked with gray background color: Optional, depending on the application

Fig. 8-6: Parallel Operation HCS

Notes on Project Planning



Parallel operation is only allowed with drive controllers of the same type current.



Mains contactor

When using the component HCS03.1E with HNK01.1, connect the mains contactor electrically before HNK and HCS03.

Control mains contactors in such a way that error messages at the converters connected in parallel can interrupt the power supply from the mains (e.g., connect Bb contacts of HCS in series).

When controlling several mains contactors, additionally make sure that the mains contactors are always controlled simultaneously and synchronously so that each HCS only has to charge its own DC bus capacitors when **power voltage is switched on**.



When **dimensioning the fuses** in the supply feeder and in branches, make sure to provide protection against overcurrent and overload in the case of error.

See [chapter 15.3.5 "Dimensioning the Line Cross Sections and Fuses"](#) on page 266

Configuring the Drive System



For **selecting the components in the mains connection**, observe the pieces of information contained in the following chapters:

- [chapter 15.1 "Determining the Appropriate Drive Controller" on page 247](#)
- [chapter 15.3.2 "Determining the Mains Filter" on page 264](#)
- [chapter 15.3.1 "Determining the Mains Choke" on page 264](#)



The **connection lines** to the drive controllers should preferably have the same impedances in order to achieve balanced load distribution at the power inputs of the drive controllers. From the common node of the lines, you therefore have to make sure that

- the lengths of the supply lines and
- the cross sections of the supply lines are the same.



At the common DC bus there is less than the sum of the device-specific performance data available. This particularly applies to the continuous DC bus power $P_{DC\ cont}$ and the continuous regenerative power P_{BD} . The sum is generated with reduced performance data. The reduction takes place with the corresponding **balancing factors for parallel operation**.

For these data, see Project Planning Manual "Rexroth IndraDrive Supply Units and Power Sections" → Chapter of the respective device → "Technical Data" → "Basic Data" → table "Data of Power Section - DC Bus".

Parallel Operation HCS - Number of Components

Converter HCS02	Components at common DC bus	
	HLB01.1	HLC01.1
HCS02.1E-W0012	No DC bus connection	
HCS02.1E-W0028	8	Limited to charging ability C_{DCext} of the individual HCS
HCS02.1E-W0054	6	
HCS02.1E-W0070	4	
Converter HCS03		
HCS03.1E-W0070	10	Not allowed, as no charging ability C_{DCext}
HCS03.1E-W0100	8	
HCS03.1E-W0150	6	
HCS03.1E-W0210	4	Limited to charging ability C_{DCext} of the individual HCS

Tab.8-4: Parallel Operation IndraDrive Converters

Example Allowed parallel operation of HCS03.1E:

6 × HCS03.1E-W00150

8.2.4 Third-Party Supply Units

General Information

HMS01 and HMD01 power sections are designed to be supplied via HMV supply units or HCS converters. In exceptional cases, other supply units (called "third-party supply units" in the following paragraphs) can be used as supply units (e.g., SFT from the product range RD500). Third-party supply units cause loading which requires **additional measures**.



The **C-UL listing** of HMS and HMD applies under the condition that they are supplied by HMV supply units or HCS converters.

Block Diagram

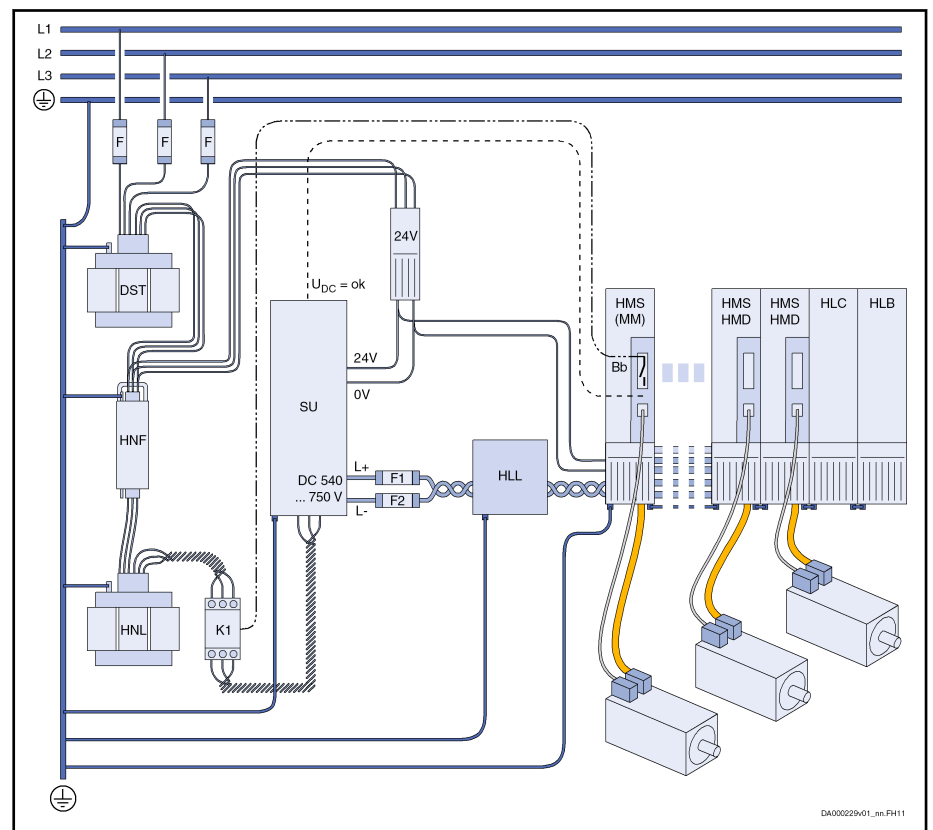

- HLL DC bus choke
- MM Module bus master
- SU Third-party supply unit

Fig. 8-7: Third-Party Supply Unit With One Drive System

Notes on Project Planning

Only HMS01 / HMD01 inverters, as well as additional components HLB and HLC, may be operated with third-party supply units.

Requirements to the third-party supply unit:

- **Minimum inductance:** In the mains connection of the third-party supply unit, install a mains choke with at least 100 µH.
- **DC bus voltage:** The DC bus voltage of the third-party supply unit must be in the range DC 540 ... 750 V. Take the limit values $U_{DC_LIMIT_max}$ of the supplied devices into account.
- **Allowed voltage control:** Sine-wave modulation with $f_s \geq 4.2$ kHz.

Third-party supply units with block modulation or flat-top modulation are **not** allowed.

Configuring the Drive System

Requirements to the drive system:

- **DC bus choke:** Per drive system, use one additional component HLL01.1N for connection to the DC bus of the third-party supply unit.
- **DC bus current:** Comply with maximum allowed DC bus current of 100 A.
- **Additional capacitances:** Use at least **50 µF** per kW of installed continuous power in the form of DC bus capacitor unit HLC01.
- **Leakage capacitance C_{ab} :** The leakage capacitance per drive system (motors and motor cables) mustn't be more than a maximum of 500 nF.
- **Capacitances against housing C_{γ} :** Per drive system, the capacitance against housing mustn't exceed 2×850 nF (850 nF at L+, 850 nF at L-) and mustn't fall below 2×300 nF (300 nF at L+, 300 nF at L-).
- **Peak voltage:** Limit voltage L+ against \ominus and L- against \ominus to a maximum of 1 kV.
- If the drive system can be disconnected from the third-party supply unit in operation (e.g., in the case of overcurrent by fuses), use **DC bus resistor unit HLB01** with $W_{\max} \geq W_{\max_installiert}$.

Notes on Commissioning

Supply units, converters, inverters and additional components of the Rexroth IndraDrive product range have a module bus X1. Via the module bus, information on the status within the drive system is exchanged and the power supply from the mains is influenced.

Supply units of other product ranges have no module bus. With the drive firmware as of version MPx-04VRS, you can configure an inverter as module bus master. Integrate the relay contact of the module bus master configured as Bb contact in the control circuit of the power supply in such a way that the circuit is interrupted when the relay contact opens.

 For information on configuration and parameterization of the drive controllers, see Functional Description of firmware, chapter "Power Supply" and the pertinent parameters

- P-0-0860, Converter configuration
- P-0-0861, Power supply status word

Take the information on circuits for the mains connection into account (see [chapter 9 "Circuits for the Mains Connection" on page 141](#)).

8.3 Mains Connection Supply Units and Converters

8.3.1 General Information

The mains connection consists of:

- Protection against overload (e.g., fuses for line protection)



When **dimensioning the fuses** in the supply feeder and in branches, make sure to provide protection against overcurrent and overload in the case of error.

See [chapter 15.3.5 "Dimensioning the Line Cross Sections and Fuses" on page 266](#)

- If necessary, an autotransformer or isolating transformer for voltage adjustment
- HNF mains filter

Configuring the Drive System

- HNL mains choke
 - If necessary, combination of mains filter and HNK mains choke
 - Mains contactor (integrated for some HMV)
- Notes on Project Planning** From the tables in the following chapters, select the mains connection for the projected supply (HMV or HCS) and take the given values into account. If necessary, split the drive system up or use a more powerful mains filter (e.g., type "M900" instead of type "F240").
- **C_y** (capacitance against housing)

This capacitance must be charged by the supply unit or converter when the mains voltage is switched on and is limited by the charging ability of the supply units and converters.

In the technical data, you can find the value of C_y for each component at the DC bus.

The value C_y mustn't fall below the required minimum value to attenuate and avoid oscillation in the mains connection.
 - **Max. number of axes**

The allowed number of axes is limited by the mains filter, because the leakage current generated by the drive system loads the mains filter.
 - **Max. leakage capacitance $C_{ab,g}$**

Due to the leakage capacitance (capacitance of cables and motor), leakage current, which loads the mains filter, is generated by the switching at the output of the inverter.

In the column "EMC limit value class to be achieved", you can find, for the selected mains connection (mains filter, mains choke), the leakage capacitance with which the combination can comply with the respective EMC limit value class.
 - **Motor cable length**

The length of the motor cable determines the leakage capacitance. With the switching frequency which has been set, the leakage current is generated due to the leakage capacitance. The specified values of the motor cable length (switching frequency f_s) cause the same load and filter effect at the mains filter and are to be understood as guide values.

Configuring the Drive System

NOTICE**Property damage due to mains filter overload!**

- Do not connect mains filters in series, as this can cause resonance effects on current and voltage.
- Comply with the specified limits of C_y (capacitances against housing), maximum leakage capacitance $C_{ab,g}$ and maximum number of axes, because otherwise the mains filter can lose its effect and get damaged.
- Only operate expressly allowed components at mains filters.

Do not operate any other components, such as additional power supply units and fans, at HNF mains filters.

With mains filters at compensation units, make sure there aren't any resonance effects on current and voltage.

Observe the allowed harmonic limit values (THD) of the filter components (see [chapter 15.3.7 "Determining the Allowed Operating Data of Mains Filters" on page 273](#)).

Make sure that the nominal current of the mains contactor does not exceed the nominal current of the mains filter.

**Circuit for the mains connection**

Observe the [chapter 9 Circuits for the Mains Connection, page 141](#).

**Mains filters HNF01, NFD at mains grounded via outer conductor**

HNF01.1 or NFD03.1 mains filters are not suited for operation on mains grounded via outer conductor.

Observe the allowed mains connection voltage in the technical data of the respective component.

Install an isolating transformer.

**Performance data without mains choke**

Operation without mains choke is only allowed for certain supply units and converters.

Take into account that supply units and converters, when operated **without mains choke**, have **reduced performance data** in comparison to normal operation with mains choke.

Performance data: See technical data of the respective component



EMC limit values and mains filter selection

Explanation on the sizing criterion EMC limit value class:

- See [chapter 10.1.3 "Noise Emission of the Drive System" on page 182](#)
- Calculation formulas for determining the allowed leakage capacitances:
See [chapter 15.3.6 "Determining the Leakage Capacitance" on page 272](#)
- The mains filters used have been specifically dimensioned for Rexroth drive systems. For filters by other manufacturers, Rexroth cannot guarantee mains interference suppression with regard to allowed limit values.
- The indicated EMC limit values apply to **grounded** mains. Ungrounded mains require additional measures.

The selection tables do not contain all practical applications (e.g., use of mains filters and mains chokes by several drive systems). For such cases, mains filters and mains choke can be selected, too:

- See [chapter 15.3.1 "Determining the Mains Choke" on page 264](#)
- See [chapter 15.3.2 "Determining the Mains Filter" on page 264](#)

8.3.2 Mains Connection of HMV Supply Units

Mains Connection of HMV Supply Units - Additional Components



Use HNL mains choke and HNF mains filter

For interference-free operation of supply units with regeneration back to the mains (HMVxx.xR), use appropriate HNL mains chokes and HNF mains filters in the mains connection.

Supply unit	Transformer		Mains filter			Mains choke		
	DST (auto)	DLT (isolating)	HNF01.1*- ****-R****	HNF01.1*- ****-E****	HNS 02.1	HNL01.1E; HNL01.1E- ****-S	HNL01.1R; HNL01.1R- ****-S	HNL 02.1
HMV01.1E-W	■	■	-	■	-	■	-	-
HMV01.1R-W	■	■	■ (!)	-	-	-	■ (!)	-
HMV02.1R-W	■	■	-	-	■ (!)	-	-	■ (!)

- Allowed
- (!) Must be used
- Not allowed

Tab.8-5: Additional Components Mains Connection

Configuring the Drive System

Mains Connection of HMV01.1E Supply Units

Supply unit	Mains chokes	Mains filter	Explanation	EMC limit value class to be achieved ¹⁾ : Max. leakage capacitance $C_{ab,g}$; motor cable length
HMV01.1E-W0030	HNL01.1E-0400-N0051	HNF01.1A-F240-E0051	Standard combination for axis systems with $C_y \leq 2 \times 1225$ nF Number of axes ≤ 18	A1: 290 nF; 280 m ($f_s = 8$ kHz) 110 m ($f_s = 12$ kHz)
	Without		Reduced performance data; see Project Planning Manual	
	HNL01.1E-0400-N0051	HNF01.1A-M900-E0051	Standard combination for axis systems with $C_y \leq 2 \times 2040$ nF Number of axes ≤ 40	A1: 1100 nF; 1,050 m ($f_s = 8$ kHz) 270 m ($f_s = 12$ kHz)
	Without		Reduced performance data; see Project Planning Manual	
	HNL01.1E-0400-N0051 with HNL01.1E-5700-S0051	Customer-side	Standard mains choke connected in series with current-compensated mains choke to reduce line-frequency leakage currents	Not specified
	Without	Without	Not allowed	
HMV01.1E-W0075	HNL01.1E-0200-N0125	HNF01.1A-F240-E0125	Standard combination for axis systems with $C_y \leq 2 \times 1225$ nF Number of axes ≤ 18	A2.2: 290 nF; 280 m ($f_s = 8$ kHz) 110 m ($f_s = 12$ kHz)
	Without		Reduced performance data; see Project Planning Manual	
	HNL01.1E-0200-N0125	HNF01.1A-M900-E0125	Standard combination for axis systems with $C_y \leq 2 \times 2040$ nF Number of axes ≤ 40	A2.2: 1100 nF; 1,050 m ($f_s = 8$ kHz) 270 m ($f_s = 12$ kHz)
	Without		Reduced performance data; see Project Planning Manual	
	HNL01.1E-0200-N0125 with HNL01.1E-2800-S0125	Customer-side	Standard mains choke connected in series with current-compensated mains choke to reduce line-frequency leakage currents	Not specified
	Without	Without	1 axis (1 HMD01)	A2.1: 40 nF; 40 m ($f_s = 8$ kHz) 40 m ($f_s = 12$ kHz)

Configuring the Drive System

Supply unit	Mains chokes	Mains filter	Explanation	EMC limit value class to be achieved ¹⁾ : Max. leakage capacitance $C_{ab,g}$; motor cable length
HMV01.1E-W0120	HNL01.1E-0100-N0202	HNF01.1A-F240-E0202	Standard combination for axis systems with $C_y \leq 2 \times 1225$ nF Number of axes ≤ 18	A2.2: 290 nF; 280 m ($f_s = 8$ kHz) 110 m ($f_s = 12$ kHz)
	Without		Reduced performance data; see Project Planning Manual	
	HNL01.1E-0100-N0202	HNF01.1A-M900-E0202	Combination for axis systems with $C_y \leq 2 \times 2040$ nF Number of axes ≤ 40	A2.2: 1100 nF; 1,050 m ($f_s = 8$ kHz) 270 m ($f_s = 12$ kHz)
	Without		Reduced performance data; see Project Planning Manual	
	HNL01.1E-0100-N0202 with HNL01.1E-3400-S0202	Customer-side	Standard mains choke connected in series with current-compensated mains choke to reduce line-frequency leakage currents	Not specified
	Without	Without	1 axis (1 HMD01)	A2.1: 40 nF; 40 m ($f_s = 8$ kHz) 40 m ($f_s = 12$ kHz)

1) In grounded mains

Tab.8-6: Selection of Mains Connection HMV01.1E

Mains Connection of HMV01.1R Supply Units

Supply unit	Mains chokes	Mains filter	Explanation	EMC limit value class to be achieved ¹⁾ : Max. leakage capacitance $C_{ab,g}$; motor cable length
HMV01.1R-W0018	HNL01.1R-0980-C0026	HNF01.1A-F240-R0026	Standard combination for axis systems with $C_y \leq 2 \times 1225$ nF Number of axes ≤ 18	A1: 290 nF; 280 m ($f_s = 8$ kHz) 110 m ($f_s = 12$ kHz)
	HNL01.1R-0980-C0026	HNF01.1A-M900-R0026	Standard combination for axis systems with $C_y \leq 2 \times 2040$ nF Number of axes ≤ 40	A1: 1100 nF; 1,050 m ($f_s = 8$ kHz) 270 m ($f_s = 12$ kHz)
	HNL01.1R-0980-C0026 with HNL01.1R-4200-S0026	Customer-side	Standard mains choke connected in series with current-compensated mains choke to reduce line-frequency leakage currents	n.s.

Configuring the Drive System

Supply unit	Mains chokes	Mains filter	Explanation	EMC limit value class to be achieved ¹⁾ ; Max. leakage capacitance $C_{ab,g}$; motor cable length
HMV01.1R-W0045	HNL01.1R-0590-C0065	HNF01.1A-F240-R0065	Standard combination for axis systems with $C_y \leq 2 \times 1225$ nF Number of axes ≤ 18	A1: 290 nF; 280 m ($f_s = 8$ kHz) 110 m ($f_s = 12$ kHz)
	HNL01.1R-0590-C0065	HNF01.1A-M900-R0065	Standard combination for axis systems with $C_y \leq 2 \times 2040$ nF Number of axes ≤ 40	A1: 1100 nF; 1,050 m ($f_s = 8$ kHz) 270 m ($f_s = 12$ kHz)
	HNL01.1R-0590-C0065 with HNL01.1R-6300-S0065	Customer-side	Standard mains choke connected in series with current-compensated mains choke to reduce line-frequency leakage currents	n.s.
HMV01.1R-W0065	HNL01.1R-0540-C0094	HNF01.1A-F240-R0094	Standard combination for axis systems with $C_y \leq 2 \times 1225$ nF Number of axes ≤ 18	A2.2: 290 nF; 280 m ($f_s = 8$ kHz) 110 m ($f_s = 12$ kHz)
	HNL01.1R-0540-C0094	HNF01.1A-M900-R0094	Standard combination for axis systems with $C_y \leq 2 \times 2040$ nF Number of axes ≤ 40	A2.2: 1100 nF; 1,050 m ($f_s = 8$ kHz) 270 m ($f_s = 12$ kHz)
	HNL01.1R-0540-C0094 with HNL01.1R-3000-S0094	Customer-side	Standard mains choke connected in series with current-compensated mains choke to reduce line-frequency leakage currents	n.s.
HMV01.1R-W0120	HNL01.1R-0300-C0180	HNF01.1A-H350-R0180	Standard combination for axis systems with $C_y \leq 2 \times 1020$ nF Number of axes ≤ 15	A2.2: 450 nF; 350 m ($f_s = 8$ kHz)

¹⁾ In grounded mains
Tab.8-7: Selection of Mains Connection HMV01.1R

Mains Connection of HMV02.1R Supply Units

Supply unit	Mains choke	Mains filter	Explanation	EMC limit value class to be achieved ¹⁾ ; motor cable length
HMV02.1R-W0015	HNL02.1R-0980-C0023	HNS02.1A-Q200-R0023	Standard combination for axis systems with $C_y \leq 2 \times 1225$ nF Number of axes ≤ 12	A2.1; 200 m ($f_s = 8$ kHz)

¹⁾ In grounded mains
Tab.8-8: Selection of Mains Connection HMV02.1R

Configuring the Drive System

Supply unit	Mains choke	Mains filter	Explanation	EMC limit value class to be achieved ¹⁾ ; motor cable length
HMV02.1R-W0015	HNL02.1R-0980-C0023	HNS02.1A-Q200-R0023	Standard combination for axis systems with $C_y \leq 12 \times 200 \text{ nF}$	A2.1; 200 m ($f_s = 8 \text{ kHz}$)

1) In grounded mains
 Tab.8-9: Mains Connection HMV02.1R



For the connections from the supply unit to the axis systems, observe the information contained in chapter [chapter 13.1.6 "Connection of the DC Bus Connections"](#) on page 228.

8.3.3 Mains Connection for HCS Converters

Mains Connection for HCS Converters - Additional Components

Converter	Transformer		Mains filter			Mains choke		
	DST (auto)	DLT (isolating)	NFD03.1	HNF01.1*- ****-R****	HNF01.1*- ****-E****	HNK01.1	HNL01.1E; HNL01.1E- ****-S	HNL01.1R; HNL01.1R- ****-S
HCS02.1E	■	■	■	■ ¹⁾	■ ¹⁾	-	■	-
HCS03.1E	■	■	■ ²⁾	■ ¹⁾	■ ¹⁾	■	■	-

- Allowed
 - Not allowed
 - 1) Observe the note "Minimum value capacitance against ground at the DC bus!"
 - 2) Maximum allowed motor cable length: 5 m
- Tab.8-10: Additional Components in the Mains Connection of Converters



Minimum value capacitance against housing at the DC bus!

When using HNF01.1 mains filters at HCS02.1 or HCS03.1, or when using HMS01, HMS02 or HMD01 at HCS02.1 or HCS03.1, make sure that at least **330 nF** each take effect against ground at the DC bus of the combined drive system at L+ and L-.

Use the accessory **HAS04**, if the drive system falls below this capacitance value.

See Project Planning Manual "Rexroth IndraDrive Supply Units and Power Sections" → Chapter of the respective device → "Technical Data" → "Mechanical System and Mounting" → "Dimensions, Mass, Insulation, Sound Pressure Level"

Drive controller	Capacitance against housing C_y ¹⁾	Use of HAS04 ^{2) 3)} required if ...
HMS01.1N: < W0110	2 × 68 nF	Number of HMS01 ≤ 3
HMS01.1N: ≥ W0110	2 × 100 nF	Number of HMS01 ≤ 2

Configuring the Drive System

Drive controller	Capacitance against housing $C_y^{1)}$	Use of HAS04 ^{2) 3)} required if ...
HMS02	2 × 68 nF	Number of HMS02 ≤ 3
HMD01	2 × 68 nF	Number of HMD01 ≤ 3
HCS02	2 × 100 nF	Number of HCS02 ≤ 2 ⁴⁾
HCS03	2 × 100 nF	Number of HCS03 ≤ 2 ⁴⁾
KCU01	2 × 470 nF	Not required
KCU02	2 × 100 nF	
Accessory HAS04		
HAS04.1-001 for HCS02	2 × 470 nF	
HAS04.1-002 for HCS03	2 × 470 nF	

- 1) See also Project Planning Manual "Rexroth IndraDrive Supply Units and Power Sections"
- 2) See Project Planning Manual "Rexroth IndraDrive Additional Components and Accessories"
- 3) The number of drive controllers specified in this column already allows for the available capacitance (100 nF) of an HCS02 or HCS03 in the drive system. Example of a drive system with HCS02 and HMS02:
 $1 \times \text{HCS02} + 3 \times \text{HMS02} = 1 \times 100 \text{ nF} + 3 \times 68 \text{ nF} = 304 \text{ nF}$; $304 \text{ nF} < 330 \text{ nF} \Rightarrow$ HAS04 required; with $1 \times \text{HCS02} + 4 \times \text{HMS02}$, the HAS04 would not be required
- 4) HAS04 is only required, when an HNF01.1 mains filter is present in the drive system

Tab.8-11: C_y , Capacitances against Housing

Mains Connection for HCS02 Converters

Converter	Mains chokes	Mains filter	Explanation	EMC limit value class to be achieved ¹⁾ : Max. leakage capacitance C_{ab_g}
HCS02.1E-W0012	HNL01.1E-1000-N0012 (optional)	NFD03.1-480-007	Standard combination for 1 converter	A2.1
	HNL01.1E-1000-N0020	NFD03.1-480-016	<i>Group Supply</i> <ul style="list-style-type: none"> Type current HCS02 ≤ W0012 Motor cable length ≤ 120 m ($f_s = 8 \text{ kHz}$) 	A2.2: 60 nF A1: 50 nF B1: 40 nF
HCS02.1E-W0028	HNL01.1E-1000-N0012 (optional)	NFD03.1-480-016	Standard combination for 1 converter	A2.1
	HNL01.1E-0600-N0032	NFD03.1-480-030	<i>Group Supply</i> <ul style="list-style-type: none"> Type current HCS02 ≤ W0028 Motor cable length ≤ 120 m ($f_s = 8 \text{ kHz}$) 	A2.2: 80 nF A1: 50 nF

Configuring the Drive System

Converter	Mains chokes	Mains filter	Explanation	EMC limit value class to be achieved ¹⁾ : Max. leakage capacitance $C_{ab,g}$
HCS02.1E-W0054	HNL01.1E-1000-N0020	NFD03.1-480-030	Standard combination for 1 converter	A2.1
	HNL01.1E-1000-N0020	NFD03.1-480-030	<i>Central supply to axis systems</i> <ul style="list-style-type: none"> Type current HMS \leq W0054 	A2.2: 80 nF A1: 50 nF
	HNL01.1E-1000-N0020	NFD03.1-480-055	<ul style="list-style-type: none"> Type current HMD \leq W0020 Type current HCS \leq W0054 Sum of type currents \leq 198 (without mains choke \leq 120) $C_y \leq 2 \times 600$ nF Motor cable length \leq 120 m ($f_s = 8$ kHz) 	A2.2: 110 nF A1: 70 nF B1: 55 nF
	HNL01.1E-1000-N0020	HNF01.1A-F240-R0026	<i>Central supply to axis systems</i> <ul style="list-style-type: none"> Type current HMS \leq W0054 Type current HMD \leq W0020 Type current HCS \leq W0054 Sum of type currents \leq 198 (without mains choke \leq 120) 2×330 nF $\leq C_y \leq 2 \times 1225$ nF Motor cable length \leq 240 m ($f_s = 8$ kHz) 	A2.2: 350 nF A1: 300 nF B1: 89 nF
	HNL01.1E-1000-N0020	HNF01.1A-M900-R0026	<i>Central supply to axis systems</i> <ul style="list-style-type: none"> Type current HMS \leq W0054 	A2.2: 350 nF
	HNL01.1E-1000-N0020	HNF01.1A-M900-E0051	<ul style="list-style-type: none"> Type current HMD \leq W0020 Type current HCS \leq W0054 Sum of type currents \leq 198 (without mains choke \leq 120) 2×330 nF $\leq C_y \leq 2 \times 1225$ nF Motor cable length \leq 900 m ($f_s = 8$ kHz) 	A2.2: 350 nF A1: 350 nF B1: 350 nF

Configuring the Drive System

Converter	Mains chokes	Mains filter	Explanation	EMC limit value class to be achieved ¹⁾ : Max. leakage capacitance $C_{ab,g}$
HCS02.1E-W0070	HNL01.1E-0600-N0032	NFD03.1-480-055	Standard combination for 1 converter	A2.1
	HNL01.1E-0600-N0032	NFD03.1-480-055	<i>Central supply to axis systems</i> <ul style="list-style-type: none"> Type current HMS \leq W0054 Type current HMD \leq W0036 	A2.2: 100 nF A1: 70 nF B1: 52 nF
	HNL01.1E-0600-N0032	NFD03.1-480-075	<ul style="list-style-type: none"> Type current HCS \leq W0070 Sum of type currents \leq 270 (without mains choke \leq 120) Motor cable length \leq 120 m ($f_s = 8$ kHz) 	A2.2: 110 nF A1: 70 nF B1: 55 nF
	HNL01.1E-0600-N0032	HNF01.1A-M900-E0051	<i>Central supply to axis systems</i> <ul style="list-style-type: none"> Type current HMS \leq W0054 Type current HMD \leq W0036 Type current HCS \leq W0070 Sum of type currents \leq 270 $2 \times 330 \text{ nF} \leq C_y$ Motor cable length \leq 900 m ($f_s = 8$ kHz) 	A2.2: 350 nF

¹⁾ In grounded mains

Tab.8-12: Selection of Mains Connection HCS02

Mains Connection for HCS03 Converters



With HCS03.1E drive controllers, the **limit value class A2** (see "Limit Values for Line-Based Disturbances") can be achieved in grounded mains when using the listed mains filters HNF01.1A or HNK01.1A or NFD03.1.

Observe notes in chapter [11 Arranging the Components in the Control Cabinet](#), page 189.

Configuring the Drive System

Converter	Mains chokes	Mains filter	Explanation
HCS03.1E-W0070	HNK01.1A-A075-E0050		Standard combination for 1 converter Motor cable length ≤ 75 m
	HNL01.1E-0571-N0050	-	Standard for operating one drive controller without mains filter
	HNL01.1E-0571-N0050	NFD03.1-480-055	Combination for 1 converter Motor cable length ≤ 5 m
	HNL01.1E-0571-N0050	HNF01.1A-F240-E0051	<i>Central supply to axis systems</i> <ul style="list-style-type: none"> • Type current HMS \leq W0054 • Type current HMD \leq W0036 • Sum of type currents ≤ 270 • 2×330 nF $\leq C_y \leq 2 \times 600$ nF • Motor cable length ≤ 240 m ($f_s = 8$ kHz)
	HNL01.1E-0571-N0050	HNF01.1A-M900-E0051	<i>Central supply to axis systems</i> <ul style="list-style-type: none"> • Type current HMS \leq W0054 • Type current HMD \leq W0036 • Sum of type currents ≤ 270 • 2×330 nF $\leq C_y \leq 2 \times 1225$ nF • Motor cable length ≤ 900 m ($f_s = 8$ kHz)
	HNL01.1E-0400-N0051 with HNL01.1E-5700-S0051	Customer-side	Standard mains choke connected in series with current-compensated mains choke to reduce line-frequency leakage currents

Configuring the Drive System

Converter	Mains chokes	Mains filter	Explanation
HCS03.1E-W0100	HNK01.1A-A075-E0080		Standard combination for 1 converter Motor cable length ≤ 75 m
	HNL01.1E-0362-N0080	-	Standard for operating one drive controller without mains filter
	HNL01.1E-0362-N0080	NFD03.1-480-075	Combination for 1 converter Motor cable length ≤ 5 m
	HNL01.1E-0362-N0080	HNF01.1A-F240-E0125	<i>Central supply to axis systems</i> <ul style="list-style-type: none"> • Type current HMS \leq W0070 • Type current HMD \leq W0036 • Sum of type currents ≤ 270 • 2×330 nF $\leq C_y \leq 2 \times 600$ nF • Motor cable length ≤ 240 m ($f_s = 8$ kHz)
	HNL01.1E-0362-N0080	HNF01.1A-M900-E0125	<i>Central supply to axis systems</i> <ul style="list-style-type: none"> • Type current HMS \leq W0070 • Type current HMD \leq W0036 • Sum of type currents ≤ 270 • 2×330 nF $\leq C_y \leq 2 \times 1225$ nF • Motor cable length ≤ 900 m ($f_s = 8$ kHz)
	HNL01.1E-0362-N0080 with HNL01.1E-2800-S0125	Customer-side	Standard mains choke connected in series with current-compensated mains choke to reduce line-frequency leakage currents

Configuring the Drive System

Converter	Mains chokes	Mains filter	Explanation
HCS03.1E-W0150	HNK01.1A-A075-E0106		Standard combination for 1 converter Motor cable length ≤ 75 m
	HNL01.1E-0240-N0106	-	Standard for operating one drive controller without mains filter
	HNL01.1E-0240-N0106	NFD03.1-480-130	Combination for 1 converter Motor cable length ≤ 5 m
	HNL01.1E-0240-N0106	HNF01.1A-F240-E0125	<i>Central supply to axis systems</i> <ul style="list-style-type: none"> Type current HMS \leq W0070 Type current HMD \leq W0036 Sum of type currents ≤ 270 $2 \times 330 \text{ nF} \leq C_y \leq 2 \times 600 \text{ nF}$ Motor cable length ≤ 240 m ($f_s = 8$ kHz)
	HNL01.1E-0240-N0106	HNF01.1A-M900-E0125	<i>Central supply to axis systems</i> <ul style="list-style-type: none"> Type current HMS \leq W0070 Type current HMD \leq W0036 Sum of type currents ≤ 270 $2 \times 330 \text{ nF} \leq C_y \leq 2 \times 1225 \text{ nF}$ Motor cable length ≤ 900 m ($f_s = 8$ kHz)
	HNL01.1E-0240-N0106 with HNL01.1E-2800-S0125	Customer-side	Standard mains choke connected in series with current-compensated mains choke to reduce line-frequency leakage currents

Configuring the Drive System

Converter	Mains chokes	Mains filter	Explanation
HCS03.1E-W0210	HNK01.1A-A075-E0146		Standard combination for 1 converter Motor cable length ≤ 75 m
	HNL01.1E-0170-N0146	-	Standard for operating one drive controller without mains filter
	HNL01.1E-0170-N0146	NFD03.1-480-180	Combination for 1 converter Motor cable length ≤ 5 m
	HNL01.1E-0170-N0146	HNF01.1A-F240-E0202	<i>Central supply to axis systems</i> <ul style="list-style-type: none"> Type current HMS \leq W0150 Type current HMD \leq W0036 Sum of type currents ≤ 270 2×330 nF $\leq C_y \leq 2 \times 600$ nF Motor cable length ≤ 240 m ($f_s = 8$ kHz)
	HNL01.1E-0170-N0146	HNF01.1A-M900-E0202	<i>Central supply to axis systems</i> <ul style="list-style-type: none"> Type current HMS \leq W0150 Type current HMD \leq W0036 Sum of type currents ≤ 270 2×330 nF $\leq C_y \leq 2 \times 1225$ nF Motor cable length ≤ 900 m ($f_s = 8$ kHz)
	HNL01.1E-0170-N0146 with HNL01.1E-3400-S0202	Customer-side	Standard mains choke connected in series with current-compensated mains choke to reduce line-frequency leakage currents

Tab.8-13: Selection of Mains Connection HCS03

8.4 Additional Components

8.4.1 Additional Components at the DC Bus

General Information

Converters and supply units basically differ in the following features:

- Braking resistor integrated
- Possible connection for external HLR braking resistor
- Operation of DC bus resistor unit HLB
- Operation of DC bus capacitor unit HLC
- Need of HLL chokes for operation



Take value $C_{DC_{ext}}$ into account when operating HLC01!

Observe the different abilities which HMV supply units and HCS converters have to charge external capacitances at the DC bus (L+, L-).

Take the value $C_{DC_{ext}}$ into account which is contained in the technical data of the respective device.

See also Project Planning Manual "Rexroth IndraDrive Supply Units and Power Sections" → "HCS03 Power Sections" → "Technical Data" → "Basic Data" → Data of Power Section - DC bus

In the HCS03 product series, it is only allowed to operate external capacitances at the DC bus for the HCS03.1E-W0210 type.

Allowed Combinations

The table below shows which additional components are allowed at the DC bus of HMV supply units and HCS converters.



Project planning of HLC

Take the charging ability $C_{DC_{ext}}$ of the used supply unit or converter into account.

Supply unit or converter	HLB01.1C	HLB01.1D	HLC01.1C	HLC01.1D	HLR01.1	HLL02.1
HMV01.1E-W	-	■	■ ²⁾	■	-	-
HMV01.1R-W	-	≤ 2	■ ²⁾	■	-	-
HMV02.1R-W	■ ≤ 2	-	■	-	-	-
HCS02.1	■	■ ²⁾	■	■ ²⁾	■ ³⁾	-
HCS03.1	■ ²⁾	■	-	■ ¹⁾	■ ⁴⁾	-

- Allowed
- (!) Must be used
- Not allowed
- 1) Only HCS03.1E-...-W0210
- 2) Different mounting depths: Control cabinet adapter HAS03 required
- 3) HCS02.1E-W0054, -W0070 (standard equipment: braking transistor integrated)
- 4) HCS03.1E in optional design -xxBx (integrated braking transistor) required

Tab.8-14: Combinations With Additional Components

Configuring the Drive System

HLR Braking Resistors and DC Bus Resistor Units HLB

NOTICE

High temperatures in the proximity of braking resistors!

Mount the braking resistors to temperature-resistant mounting surfaces in such a way that the air can freely enter and escape and heat does not accumulate.

Take the minimum distances d_{top} , d_{bot} and d_{hor} into account.

Take into account that the temperatures in the range of the indicated minimum distances can be above 250 °C.

Leave sufficient distance to combustible objects and take into account that braking resistors dissipate a lot of heat.

Make sure there is free cooling air supply at the bottom d_{bot} and cooling air discharge at the top d_{top} .

The space must be able to discharge the energy converted by the braking resistor.

Selection Aid for Additional Components HLR, HLB

Criterion	DC bus resistor unit HLB	Braking resistor HLR
Regenerative operation with great energy contents, e.g. <ul style="list-style-type: none"> Deceleration of great centrifugal masses at centrifuges Long braking processes for crane lifting gears 	□ Take energy absorption capacity and continuous power into account	■ Type of construction N Check use of HMVxx.xR
Kinetic energy is generated in control cabinet and can be dissipated	■	□ Type of construction A
Kinetic energy cannot be dissipated in control cabinet	-	■ Type of construction N Observe degree of protection
Quick discharge of DC bus required	■ DC bus short circuit device Observe the note "Risk of fire caused by the "sacrificing behavior" of the ZKS stage!"	-
Deceleration of synchronous motors in the case of error "mains failure"	■	-
Supply unit HMV01.1R-W0120	■	-
Converter HCS02 selected	■	■
Converter HCS03 selected	■	■ Option -xxBx required

- Recommended
 □ Suited to a limited extent
 - Not allowed
Tab.8-15: Selection Aid

NOTICE**Risk of fire caused by the "sacrificing behavior" of the ZKS stage!**

The "ZKS" input activates the "DC bus short circuit" function, when the 24V control voltage has not been applied and when there isn't any current flowing to the input. This condition can occur in the following situations:

- Failure of 24V control voltage
- Wire break
- Activation of serially connected contacts (e.g. axis limit switches)

If the kinetic energy of the mechanical axis system regenerated when braking is greater than the energy absorption capacity of HLB, the HLB device remains active when braking via ZKS takes place, until it is thermally destroyed (sacrificing behavior). Risk of fire! In this case, braking via ZKS may only come into effect in the case of an emergency (e.g. activation of an axis limit switch causes the mains supply to be cut off and simultaneously causes the 24V supply of the ZKS input to be interrupted).

Install a 24V UPS, if the "sacrificing behavior" of HLB is relevant to your drive system in the case of an emergency. This prevents the braking via ZKS which causes HLB to be destroyed due to the failure of the 24V control voltage. Braking via ZKS then will only take place in cases of emergency.

**Required type data**

To select an appropriate HLR braking resistor, the following type data of the application are required:

- Peak regenerative power $P_{RS, Anlage}$
(See [chapter 15.1.7 "Peak Regenerative Power" on page 257](#))
- Continuous regenerative power $P_{RD, Anlage}$
(See [chapter 15.1.6 "Continuous Regenerative Power" on page 255](#))
- Regenerative power $W_{R, Anlage}$
(See [chapter 15.1.4 "Regenerative Power" on page 251](#))

**HCS02, HCS03 with HLR01 and simultaneously HLB01**

- The continuous power of the selected HLR01 has to be at least as high as the continuous power of the HLB used.
- Due to differences in balance, the total continuous power is lower than the sum of the individual continuous powers. The balancing factor of 0.8 is regarded as the guide value.

**Function of integrated braking resistor in HCS02 for operation with HLR01**

Braking resistors have been integrated in HCS02 drive controllers. When operating external HLR01 braking resistors, the integrated braking resistors are not loaded.

See also parameter

- P-0-0859, Data of internal braking resistor
- P-0-0860, Converter configuration

Configuring the Drive System

**Observe degree of protection!**

When mounted outdoor or at the outside of the control cabinet, observe the degree of protection IP20 of the braking resistor.

Protect the devices against intrusion of water.

**Protection against overload!**

The HCS drive controller monitors the external braking resistor by means of the firmware which calculates a thermal image of the current braking power. When the limit values for the thermal image are exceeded, the converter switches off with the error "F8820 Braking resistor overload" to protect the braking resistor against overload.

- Exclusively operate the combinations of converter - braking resistor type listed below.
- At the drive controllers HCS02 and HCS03, parameterize the performance data of the selected braking resistor in parameter "P-0-0858, Data of external braking resistor". For this purpose, from the technical data take the data on:
 - Resistance value
 - Braking resistor continuous power
 - Maximum regenerative power to be absorbed
- Activate the selected braking resistor by setting bit 8 = 1 in parameter "P-0-0860, Converter configuration".

Braking Resistors HLR01 for HCS02

Converter	Braking resistor type ¹⁾	Type of construction ²⁾	Type Dimensions ³⁾
HCS02.1E-W0054-A-03-xNNx	HLR01.1N-01K8-N40R0-...	N	O7
HCS02.1E-W0054-A-03-xNNx	HLR01.1N-03K8-N40R0-...	N	B1
HCS02.1E-W0070-A-03-xNNx	HLR01.1N-02K4-N28R0-...	N	O8
HCS02.1E-W0070-A-03-xNNx	HLR01.1N-05K5-N28R2-...	N	B2

1) Complete type with: A-007-NNNN

2) A: Device mounting; N: Version for free assembly

3) See Project Planning Manual "Rexroth IndraDrive Additional Components and Accessories", dimension tables HLR

Tab.8-16: Assignment Braking Resistors HLR ↔ HCS02

Braking Resistors HLR01 for HCS03

Converter	Braking resistor type	Type of construction ¹⁾	Type Dimensions ²⁾
HCS03.1E-W0070-A-05-xNBV	HLR01.1N-0300-N17R5-A-007-NNNN	A	See corresponding dimensional drawing
HCS03.1E-W0100-A-05-xNBV	HLR01.1N-0470-N11R7-A-007-NNNN		
HCS03.1E-W0150-A-05-xNBV	HLR01.1N-0780-N07R0-A-007-NNNN		
HCS03.1E-W0210-A-05-xNBV	HLR01.1N-1K08-N05R0-A-007-NNNN		

Configuring the Drive System

Converter	Braking resistor type	Type of construction ¹⁾	Type Dimensions ²⁾
HCS03.1E-W0070-A-05-xNBV	HLR01.1N-01K6-N18R0-A-007-NNNN	N	O5
	HLR01.1N-01K6-N18R0-A-007-NNNU		O9
HCS03.1E-W0100-A-05-xNBV	HLR01.1N-02K0-N15R0-A-007-NNNN	N	O6
	HLR01.1N-02K0-N15R0-A-007-NNNU		A10
HCS03.1E-W0150-A-05-xNBV	HLR01.1N-04K5-N07R4-A-007-NNNN	N	B1
HCS03.1E-W0210-A-05-xNBV	HLR01.1N-06K5-N06R1-A-007-NNNN	N	B2
HCS03.1E-W0070-A-05-xNBV	HLR01.1N-03K5-N19R0-A-007-NNNN	N	B1
HCS03.1E-W0100-A-05-xNBV	HLR01.1N-05K0-N15R0-A-007-NNNN	N	B2
HCS03.1E-W0150-A-05-xNBV	HLR01.1N-08K5-N08R0-A-007-NNNN	N	B3
HCS03.1E-W0210-A-05-xNBV	HLR01.1N-12K5-N05R5-A-007-NNNN	N	B4
HCS03.1E-W0070-A-05-xNBV	HLR01.1N-04K5-N18R0-A-007-NNNN	N	B2
HCS03.1E-W0100-A-05-xNBV	HLR01.1N-07K0-N14R0-A-007-NNNN	N	B3
HCS03.1E-W0150-A-05-xNBV	HLR01.1N-11K0-N07R3-A-007-NNNN	N	B3
HCS03.1E-W0210-A-05-xNBV	HLR01.1N-17K0-N05R1-A-007-NNNN	N	B5
HCS03.1E-W0070-A-05-xNBV	HLR01.1N-06K5-N18R0-A-007-NNNN	N	B2
HCS03.1E-W0100-A-05-xNBV	HLR01.1N-09K5-N13R0-A-007-NNNN	N	B3
HCS03.1E-W0150-A-05-xNBV	HLR01.1N-15K0-N08R1-A-007-NNNN	N	B4
HCS03.1E-W0210-A-05-xNBV	HLR01.1N-23K0-N05R5-A-007-NNNN	N	C2
HCS03.1E-W0070-A-05-xNBV	HLR01.1N-10K0-N18R0-A-007-NNNN	N	B3
HCS03.1E-W0100-A-05-xNBV	HLR01.1N-14K5-N13R0-A-007-NNNN	N	B4
HCS03.1E-W0150-A-05-xNBV	HLR01.1N-24K0-N07R2-A-007-NNNN	N	C3
HCS03.1E-W0210-A-05-xNBV	HLR01.1N-36K0-N05R4-A-007-NNNN	N	C4

1) A: Device mounting; N: Version for free assembly

2) See Project Planning Manual "Rexroth IndraDrive Additional Components and Accessories", dimension tables HLR

Tab.8-17: Assignment Braking Resistors HLR ↔ HCS03

8.4.2 Additional Components at the Motor Output

General Information

In conjunction with long motor cables, the steep switching edges at the motor output of the drive controllers can cause transient overvoltages and high rise of voltage at the motor. HMF01 motor filters reduce the overvoltages and rise of voltage.

Configuring the Drive System



Guide value "Rise of voltage at output"

Observe that the voltage load at the motor is almost independent of the power section used.

Especially when using **standard motors**, make sure that they comply with the occurring voltage load.

Observe the information on third-party motors at drive controllers (see documentation "Rexroth IndraDrive Drive Systems With HMV01/02 HMS01/02, HMD01, HCS02/03", index entry "Third-party motors → On drive controllers").

Use HMF01 motor filters when the allowed rise of voltage of the third-party motor is lower than the rise of voltage at the output of the inverter used (see "Data of Power Section - Inverter").

As a matter of principle, operating motors of the **IndraDyn** product range at converters and inverters of the Rexroth IndraDrive product range does not require motor filters under the specified operating conditions.

HMF01 Motor Filters

NOTICE

Damage caused by too high switching frequency!

Only operate HMF01 motor filters up to their maximum allowed switching frequency f_s .

HMF01 motor filter	Drive controller
HMF01.1A-N0K2-M0012	HCS02.1E-W0012 HCS02.1E-W0028
HMF01.1A-N0K2-M0028	HCS02.1E-W0054 HCS02.1E-W0070
HMF01.1A-N0K2-D0045-...	HCS03.1E-W0070
HMF01.1A-N0K2-D0073-...	HCS03.1E-W0100
HMF01.1A-N0K2-D0095-...	HCS03.1E-W0150
HMF01.1A-N0K2-D0145-...	HCS03.1E-W0210

Tab.8-18: Assignment HMF01 to HCS02/HCS03

8.5 Power Section, Control Section, Firmware

8.5.1 General Information

The modular structure of the IndraDrive controllers allows a combinations of control sections and power sections. There are these dependencies which are represented in tables:

- Power sections require control sections with firmware
- Encoder systems require encoder evaluations in control sections

8.5.2 Power Section - Control Section

Control section	Power section					
	HMS01	HMS02	HMD01	HCS02	HCS03	HCS04.2
CSH01.1C ¹⁾	■	■	-	■	■	-
CSH01.2C ¹⁾	■	■	-	■	■	-
CSH01.3C ¹⁾	■	■	-	■	■	■
CSB01.1N ²⁾	■	■	-	■	■	■
CSB01.1C ¹⁾	■	■	-	■	■	■
CDB01.1C ¹⁾	-	-	■	-	-	-
CSH02.1B ⁴⁾	■	■	-	■	■	-
CSB02.1A ³⁾	■	■	-	■	■	■
CSB02.1B ⁴⁾	■	■	-	■	■	■
CSE02.1A ³⁾	■	■	-	■	■	■
CDB02.1B ⁴⁾	-	-	■	-	-	-

- Allowed
 - Not allowed
 - 1) Control section can be configured
 - 2) Control section cannot be configured
 - 3) Basic scope
 - 4) Extended scope
- Tab.8-19: Combination Control Section - Power Section



Do not exceed maximum number of plug-in actions!

For a drive controller, the control section mustn't be mounted and dismantled more than a maximum of **20 times**. If this number is exceeded, the electrical data of the internal connection can be above the specified minimum requirements. This can cause malfunction of the drive controllers.

8.5.3 Control Section - Firmware

For scopes of functions and configurations of firmware versions, see Functional Description of corresponding firmware version in chapter "Reference Documentations".

Control section type ¹⁾				Firmware version
CSB01	.	1	N -FC	As of MPB-02VRS
CSB01	.	1	N -AN	As of MPB-02VRS
CSB01	.	1	C	As of MPB-02VRS
CDB01	.	1	C	As of MPD-02VRS
CSH01	.	1	C	As of MPH-02VRS
CSH01	.	2	C	As of MPH-04VRS to MPH-05VRS

Configuring the Drive System

Control section type 1)				Firmware version
CSH01	.	3	C	As of MPC-06V06
CSB02	.	1	A	As of MPB-18VRS
CSB02	.	1	B	As of MPB-18VRS
CSH02	.	1	B	As of MPH-18VRS
CDB02	.	1	B	As of MPD-18VRS
CSE02	.	1	A	As of MPE-18VRS

1) Non-configured basic design

Tab.8-20: Required Firmware Versions for Control Sections

8.5.4 Power Section - Firmware

The tables show as of which firmware versions the corresponding products are supported. The mentioned products need this or a newer firmware version for operation. Newer firmware versions are marked with "RS" (e.g. MPH-02VRS).

Inverters HMS01, HMS02, HMD01

Product Series	Type current		Design	Supported as of firmware version
HMS01.1N	- W0020	- A-07-	NNNN	MPH-02VRS; MPB-02VRS
	- W0036	- A-07-	NNNN	MPH-02VRS; MPB-02VRS
	- W0054	- A-07-	NNNN	MPH-02VRS; MPB-02VRS
	- W0070	- A-07-	NNNN	MPH-02VRS; MPB-02VRS
	- W0110	- A-07-	NNNN	MPH-02VRS; MPB-02VRS
	- W0150	- A-07-	NNNN	MPH-02VRS; MPB-02VRS
	- W0210	- A-07-	NNNN	MPH-02VRS; MPB-02VRS
HMS02.1N	- W0350	- A-07-	NNNN	MPH-02VRS; MPB-02VRS
	- F0028	- A-07-	NNNN	MPH-05V16; MPB-05V16
	- F0070	- A-07-	NNNN	MPH-05V16; MPB-05V16
	- F0110	- A-07-	NNNN	MPH-05V16; MPB-05V16
	- F0110	- A-07-	S003	MPH-05V16; MPB-05V16
	- F0150	- A-07-	NNNN	MPH-05V16; MPB-05V16
	- F0210	- A-07-	NNNN	MPH-05V16; MPB-05V16
	- W0028	- A-07-	NNNN	MPH-02V24; MPB-02V24 MPH-03V12; MPB-03V12
- W0054	- A-07-	NNNN	MPH-02V24; MPB-02V24 MPH-03V12; MPB-03V12	

Configuring the Drive System

Product Series	Type current		Design	Supported as of firmware version
HMD01.1N	- W0012	- A-07-	NNNN	MPD-02VRS
	- W0020	- A-07-	NNNN	MPD-02VRS
	- W0036	- A-07-	NNNN	MPD-02VRS

Tab.8-21: Required Firmware Versions for Inverters

Configuring the Drive System

Converter HCS01

Product Series	Performance class		Design	Required Firmware version
HCS01.1E	- W0003	- A-02-	E-S3-EC-xx-xx-xx-xx	As of MPE-16VRS
			B-ET-EC-xx-xx-xx-xx	As of MPB-16VRS
			A-CD-EC-xx-xx-xx-xx	As of MPC-17VRS
	- W0006	- A-02-	E-S3-EC-xx-xx-xx-xx	As of MPE-16VRS
			B-ET-EC-xx-xx-xx-xx	As of MPB-16VRS
			A-CD-EC-xx-xx-xx-xx	As of MPC-17VRS
	- W0009	- A-02-	E-S3-EC-xx-xx-xx-xx	As of MPE-16VRS
			B-ET-EC-xx-xx-xx-xx	As of MPB-16VRS
			A-CD-EC-xx-xx-xx-xx	As of MPC-17VRS
	- W0013	- A-02-	E-S3-EC-xx-xx-xx-xx	As of MPE-16VRS
			B-ET-EC-xx-xx-xx-xx	As of MPB-16VRS
			A-CD-EC-xx-xx-xx-xx	As of MPC-17VRS
			A-CC-EC-xx-xx-xx-xx	As of MPx-17VRS
	- W0018	- A-02-	E-S3-EC-xx-xx-xx-xx	As of MPE-16VRS
			B-ET-EC-xx-xx-xx-xx	As of MPB-16VRS
			A-CD-EC-xx-xx-xx-xx	As of MPC-17VRS
	- W0005	- A-03-	E-S3-EC-xx-xx-xx-xx	As of MPE-16VRS
			B-ET-EC-xx-xx-xx-xx	As of MPB-16VRS
			A-CD-EC-xx-xx-xx-xx	As of MPC-17VRS
	- W0008	- A-03-	E-S3-EC-xx-xx-xx-xx	As of MPE-16VRS
			B-ET-EC-xx-xx-xx-xx	As of MPB-16VRS
			A-CD-EC-xx-xx-xx-xx	As of MPC-17VRS
	- W0018	- A-03-	E-S3-EC-xx-xx-xx-xx	As of MPE-16VRS
			B-ET-EC-xx-xx-xx-xx	As of MPB-16VRS
A-CD-EC-xx-xx-xx-xx			As of MPC-17VRS	
- W0028	- A-03-	E-S3-EC-xx-xx-xx-xx	As of MPE-16VRS	
		B-ET-EC-xx-xx-xx-xx	As of MPB-16VRS	
		A-CD-EC-xx-xx-xx-xx	As of MPC-17VRS	
- W0054	- A-03-	E-S3-EC-xx-xx-xx-xx	As of MPE-17VRS	
		B-ET-EC-xx-xx-xx-xx	As of MPB-17VRS	
		A-CD-EC-xx-xx-xx-xx	As of MPC-17VRS	

Tab.8-22: Required Firmware Versions for Converters

Configuring the Drive System

Converters HCS02, HCS03,
HCS04

Product Series	Type current		Design	Supported as of firmware version
HCS02.1E	- W0012	- A-03-	LNNN	MPH-02VRS; MPB-02VRS
	- W0012	- A-03-	NNNN	MPH-02VRS; MPB-02VRS
	- W0012	- A-03-	NNNV	MPH-02V20; MPB-02V20
	- W0028	- A-03-	LNNN	MPH-02VRS; MPB-02VRS
	- W0028	- A-03-	NNNN	MPH-02VRS; MPB-02VRS
	- W0028	- A-03-	NNNV	MPH-02V20; MPB-02V20
	- W0028	- S-03-	NNNN	MPH-02VRS; MPB-02VRS
	- W0054	- A-03-	LNNN	MPH-02VRS; MPB-02VRS
	- W0054	- A-03-	NNNN	MPH-02VRS; MPB-02VRS
	- W0054	- A-03-	NNNV	MPH-02V20; MPB-02V20
	- W0070	- A-03-	LNNN	MPH-02VRS; MPB-02VRS
	- W0070	- A-03-	NNNN	MPH-02VRS; MPB-02VRS
- W0070	- A-03-	NNNV	MPH-02V20; MPB-02V20	
HCS03.1E	- W0070	- A-05-	LNBV	MPH-02VRS; MPB-02VRS
	- W0070	- A-05-	LNNV	MPH-02V11; MPB-02V11
	- W0070	- A-05-	NNBV	MPH-02VRS; MPB-02VRS
	- W0070	- A-05-	NNNV	MPH-02V11; MPB-02V11
	- W0070	- A-15-	PSPV	MPH-02VRS; MPB-02VRS
	- W0100	- A-05-	LNBV	MPH-02VRS; MPB-02VRS
	- W0100	- A-05-	LNNV	MPH-02V11; MPB-02V11
	- W0100	- A-05-	NNBV	MPH-02VRS; MPB-02VRS
	- W0100	- A-05-	NNNV	MPH-02V11; MPB-02V11
	- W0150	- A-05-	LNBV	MPH-02VRS; MPB-02VRS
	- W0150	- A-05-	LNNV	MPH-02V11; MPB-02V11
	- W0150	- A-05-	NNBV	MPH-02VRS; MPB-02VRS
	- W0150	- A-05-	NNNV	MPH-02V11; MPB-02V11
	- W0210	- A-05-	LNBV	MPH-02VRS; MPB-02VRS
	- W0210	- A-05-	LNNV	MPH-02V11; MPB-02V11
- W0210	- A-05-	NNBV	MPH-02VRS; MPB-02VRS	
- W0210	- A-05-	NNNV	MPH-02V11; MPB-02V11	
HCS04.1E	- F0500	- A-05-	NNBV	MPH-04V10; MPB-04V10
	- W0500	- A-05-	NCBV	MPH-04V10; MPB-04V10
	- W0500	- A-05-	NNBV	MPH-04V10; MPB-04V10

Configuring the Drive System

Product Series	Type current		Design	Supported as of firmware version
HCS04.2E	- W0290	- N-04-	NNNN	MPH-06V08; MPB-06V08
	- ...			
	- W1540	- N-04-	NNBN	MPB-06V08

Tab.8-23: Required Firmware Versions for Converters

Multi-Axis Converters HCQ02

Product Series	Type performance		Control section design	Master communication	Supported as of firmware version
HCQ02.1E	- W0025	- A-03-	-B-	ET	MPM-16VRS
HCT02.1E	- W0020	- A-03-	-B-	ET	MPM-16VRS

Tab.8-24: Required Firmware Versions for Converters (Multi-Axis)

Motor-Integrated Servo Drives KSM01

Product Series	Size Length	Other features	Supported as of Firmware version
KSM01.2B	- 041C	-	MPB-04V20
	- 061C	-	
	- 071C	-	
	- 076C	-	

Tab.8-25: Required Firmware Versions for KSM01

Near Motor Servo Drives KMS01

Product Series	Features	Supported as of firmware version
KMS01	B-A018-P-D7-SE-ENH-NN-NN	MPB-07VRS
	B-A018-P-D7-SE-NNN-NN-NN	

Tab.8-26: Required Firmware Versions for KMS01

Motor-Integrated Servo Drives KSM02

Product Series	Size Length	Other features	Supported as of Firmware version
KSM02.1B	- 041C	-	MPB-17V08
	- 061C	-	
	- 071C	-	
	- 076C	-	

Tab.8-27: Required Firmware Versions for KSM02

Near Motor Servo Drives KMS02

Product Series	Features	Supported as of firmware version
KMS02	B-A018-P-D7-ET-***_**_**	MPB-17V10

Tab.8-28: Required Firmware Versions for KMS02

8.5.5 Motor - Firmware

Motor type	With encoder system	Firmware version	Notes
		From	
MHD		MPx-02VRS	
MKD		MPx-02VRS	
MKE		MPx-02VRS	
	A, C	MPx-16VRS	
MSK		MPx-02VRS	
MSM	M0	MPx-16VRS	
MAF		MPx-02VRS	
	M1, M2, M6, S1, S2, S6, N0	MPx-16VRS	
MAD		MPx-02VRS	
	M1, M2, M6, S1, S2, S6, N0	MPx-16VRS	
MSP		MPx-05VRS	
MSD		MPx-02VRS	
	M1, M2, S1, S2	MPx-16VRS	
IndraDyn L MLF		MPx-02VRS	
MBS			
IndraDyn H MBSxx2		MPx-02VRS	
IndraDyn T MBT		MPx-02VRS	

Tab.8-29: Firmware Versions vs. Motors

8.5.6 Encoder System - Encoder Evaluation

The control sections of the Rexroth IndraDrive product range support different encoder systems. Evaluation of these encoder systems requires the mentioned encoder evaluations as optional modules or optional equipment.



Operating other encoder systems than the mentioned ones requires detailed control of the technical data of the encoder system used and the interface specification of the control section.

When using third-party encoders, observe that the optional modules provide different supply voltages.

Configuring the Drive System

Supported by Firmware Versions up to MPx-08

Encoder system ¹⁾	Notes	Optional module encoder evaluation	Cable for direct connection ²⁾
Rexroth IndraDyn S, A, T, H, L			
R0	Resolver	EN1	IKS4043
R1	Resolver with integrated absolute multi-turn encoder	EN1	IKS4043
S0	Optical encoder single-turn IIC, 512 increments, supply voltage 8 V	EN1	IKS4042
S1	Optical encoder single-turn HIPERFACE, 128 increments, supply voltage 7 ... 12 V	ENS	RKG4200
S2	Optical encoder single-turn EnDat2.1, 2048 increments, supply voltage 12 V	ENS	RKG4200
S3	Capacitive encoder single-turn HIPERFACE, 16 increments, supply voltage 7 ... 12 V	ENS	RKG4200
S5	Optical encoder, single-turn with 128 increments (at QSK motors) At HCQ02 requires interface code "1S" or "1N" (e.g. HCQ02.1E-W025- A-03-B-L4-1S)	ES	RKG4200
S6 (preliminary)	Optical encoder single-turn EnDat2.1, 2048 increments, supply voltage 12 V	ENS	tbd
		EC	
M0	Optical encoder multi-turn absolute IIC, 512 increments, supply voltage 8 V	EN1	IKS4042
M1	Optical encoder multi-turn absolute HIPERFACE, 128 increments, supply voltage 7 ... 12 V	ENS	RKG4200
M2	Optical encoder multi-turn absolute EnDat2.1, 2048 increments, supply voltage 12 V	ENS	RKG4200
M3	Capacitive encoder multi-turn absolute HIPERFACE, 16 increments, supply voltage 7 ... 12 V	ENS	RKG4200
M5	Optical encoder, multi-turn absolute with 128 increments (at QSK motors) At HCQ02 requires interface code "1S" or "1N" (e.g. HCQ02.1E-W025- A-03-B-L4-1S)	ES	RKG4200
M6 (preliminary)	Optical encoder multi-turn absolute EnDat2.1, 2048 increments, supply voltage 12 V	ENS	tbd
C0	Optical encoder incremental 1 V _{pp} , 2048 increments (sin/cos)	EN2	RKG0014
SHL01.1	Hall sensor box for position detection of primary part of, for example, IndraDyn L and LSF motors	EN1 ³⁾	IKS4042
SHL02.1	Hall sensor box for position detection of primary part of, for example, IndraDyn L and LSF motors	EN1 ⁴⁾	IKS4042
		ENS	RKG0027
SHL03.1	Hall sensor adapter box for position detection of the primary part of IndraDyn L MCL motors	EC	RKG0049

Configuring the Drive System

Encoder system ¹⁾	Notes	Optional module encoder evaluation	Cable for direct connection ²⁾
Rexroth ServoDyn D servo motors SF			
STG	Single-turn encoder, absolute	EN2	RKG0015
MTG	Multi-turn encoder, 4096 revs. absolute	EN2	RKG0015
Rexroth ServoDyn D servo motors SR			
	Resolver	Not supported	
Rexroth motors MKE, MKD, MHD			
A	See encoder system S1	ENS	Depending on motor type: RKG0020 or RKG0022
C	See encoder system M1	ENS	
B	See encoder system S2	ENS	
D	See encoder system M2	ENS	
K	See encoder system R1	EN1	Depending on motor type: IKS0223 or IKS0226
V	See encoder system R0	EN1	
N	See encoder system S0	EN1	
P	See encoder system M0	EN1	

- 1) See following note
- 2) Without extension and control cabinet duct
- 3) Up to MPx04VRS, only allowed on option 2 (X8)
- 4) Up to MPx04VRS, only allowed on option 2 (X8); as of MPx05VRS configurable

Tab.8-30: Combination Control Section Equipment - Motor Encoder



For the encoder system, see the type code of the selected motor.

Abbrev. Column	→	2	3	4	5	6	7	8	9	0	1	2	3	4	5	6	7	8	9	0	1	2	3	4	5	6	7	8	9	
Example:		M	S	K	0	7	0	C	-	0	4	5	0	-	N	N	-	S	1	-	U	G	0	-	N	N	N	N		

6. Encoder

- 6.1 Optical encoder, singleturn hipurface, with 128 increments = S1
- 6.2 Optical encoder, singleturn EnDat2.1, with 2048 increments = S2
- 6.3 Optical encoder, multiturn-absolute hipurface, with 128 increments = M1
- 6.4 Optical encoder, multiturn-absolute EnDat2.1, = M2

DT000002v01_en.fh11

Fig.8-8: Type Code Section of Motor

Configuring the Drive System

8.6 Combination With Other Rexroth Components

8.6.1 Combination With Components of the Control Range Rexroth IndraControl V

Operator Terminals VCP

The VCP operator terminals allow comfortable operation of the Rexroth IndraDrive drive system with the IndraControl V control range.

The operator terminals VCP02, VCP05, VCP08, VCP20 and VCP25 are suited for control cabinet mounting and operated via the serial interface RS232 (X2) of the control sections.

The comfort control panel VCP01 is operated directly at the drive controller at the connection "H1". It then replaces the supplied standard control panel. The scope of functions is described in the Operating Instructions "Rexroth IndraDrive C Drive Controllers HCS02.1, HCS03.1".



Simultaneous operation of VCP operator terminals and standard control panels or comfort control panels is allowed.

8.6.2 sercos Analog Converter

General Information

To modernize machines, the Rexroth IndraDrive range provides the possibility of operating drive controllers of the "ANAX" and "DiAx 02" ranges with analog command value input.

sercos Analog Converter

The sercos analog converter is used to

- connect control units with sercos interface to components with analog interface
- convert sercos position command values to analog speed command values

The sercos analog converter consists of:

- Housing for **HAC01.1-002** control sections
- Configurable control section with sercos master communication
 - For MAC motors at TDM drive controllers:
BASIC CDB01.1C-SE-**EN1-EN1-MA1-MA1**--NN-S-NN-FW
 - For MDD motors at DDS drive controllers:
BASIC CDB01.1C-SE-**EN2-EN2-MA1-MA1**--NN-S-NN-FW
 - BASIC CDB01.1C-SE-**ENS-ENS-MA1-MA1**-NN-S-NN-FW (preliminary)
- Firmware e.g. FWA-INDRV*-**MPD-04VRS**-**_*-***_**
- Optional accessory **HAS01.1-065-NNN-CN**



Make sure that the parameter "P-0-0860, Converter configuration" has been set to operation as "sercos analog converter" (bit 15 = 1). Wrong setting will generate the error message "F8091 Power section defective".

8.7 Connection Cables to Motor

8.7.1 General Information

The connection from drive controller to motor is established by means of two cables:

- Motor cable (power cable)
- Encoder cable

The motor cable contains lines to connect the drive controller

- to the motor windings
- to the motor holding brake
- to the temperature measurement system of the motor

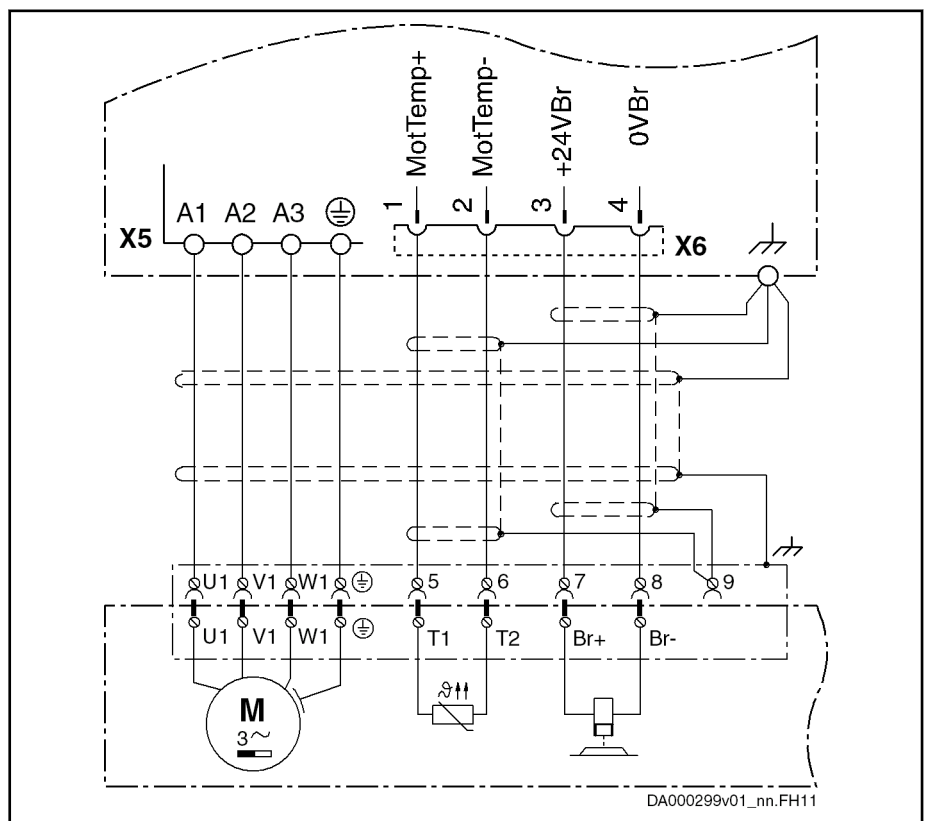

Fig. 8-9: Power Cable to Connect Drive Controller to Motor



Use shielded motor cables of the RKL series for Rexroth IndraDrive systems.



For selecting the motor cables and other connections (e.g. encoder cables), use the documentation "Rexroth Connection Cables".

8.7.2 Motor cable

General Information

For projecting and selecting the motor cable, observe the following aspects:

- Required **cross section** depending on occurring loading with continuous current and peak current
Allowed **length** depending on PWM frequency, output filter and shielding

Configuring the Drive System

- Length due to **voltage drop** on connection line to motor brake
- Other **mechanical requirements** resulting from use of motor cable, such as bending radiuses, material compatibility; see documentation "Rexroth Connection Cables".

Motor Cable Selection

 To find the appropriate cable for the selected combination of motor and drive controller, see documentation "Rexroth Connection Cables".

Allowed Length of Motor Cable

The length of the motor power cable is limited to protect the drive controllers. The longer the motor cable and the higher the switching frequency f_s of the drive controller which has been set, the higher the occurring losses.



Observe that the allowed motor cable length depends on the switching frequency f_s of the power output stage which has been set. As a matter of principle, the higher the switching frequency, the shorter the allowed cable length to protect the drive controllers against overload.

Only set such switching frequencies which are supported by the involved components! Observe the technical data for drive controllers and motors.

See also Parameter Description "P-0-0001, Switching frequency of the power output stage".

Allowed Cable Lengths at Ambient Temperature $T_{a_work} \leq 40$ °C according to EN 60 204:

PWM frequency / kHz	Allowed cable length / m		
	Without motor filter		With motor filter ³⁾
	Shielded	Unshielded ¹⁾	
2 ²⁾	100	175	200
4	75	150	200
8	38	150	Not allowed
12	25	Not allowed	Not allowed
16	18	Not allowed	Not allowed

1) Only allowed for HCS02/HCS03 drive controllers, observe note "Unshielded motor cables" below

2) Depending on the drive controller which is used

3) Additional components HMF

Tab.8-31: *Line Lengths*

**Unshielded motor cables**

Operation with unshielded motor cable

- aims at applications with "sensorless operation" (open-loop operation)
- does not include the control voltage lines to the motor; brake supply and evaluation of the temperature sensors in the motor might possibly require further measures
- requires additional measures with regard to EMC on the part of the operating company



For lines **connected in parallel**, half the indicated lengths apply.

Voltage Drop on Connection to Motor Holding Brake

The motor holding brake is controlled via the drive controller. For this purpose, the 24V supply is connected to the output at the connection point X6. To operate the motor holding brake reliably, observe its requirements on power supply.

For operating the integrated motor holding brakes of the Rexroth IndraDyn motor line at Rexroth IndraDrive controllers with Rexroth connection cables, the data of 24V supply are considered as guide values.

 For the data of 24V supply, see Project Planning Manual "Rexroth IndraDrive Supply Units and Power Sections" → Chapter of the respective device → "Technical Data" → "Basic Data" → "Data for Control Voltage Supply".

Mechanical Requirements

Depending on the application, there are different requirements.

 See the technical data of the cables in the documentation "Rexroth Connection Cables" for whether the properties comply with the requirements.

Third-Party Power Cables

Requirements on third-party motor power cables:

Maximum allowed **cable length** at A1, A2, A3:

- See chapter [8.7 Connection Cables to Motor, page 137](#)

Maximum allowed **capacitance per unit length** at A1, A2, A3:

- Against ground, each: 0.5 nF/m
- Against each other: 0.5 nF/m

Maximum allowed **inductance per unit length** at A1, A2, A3:

- 100 nH/m each



If you use third-party motor cables not corresponding to the requirements, Rexroth's guarantee for the drive system will expire.
Use ready-made cables by Rexroth.



To select the cables, use the documentation "Rexroth Connection Cables".

Configuring the Drive System

8.7.3 Encoder Cables

 To find the appropriate cable for the selected combination of motor with encoder and the respective encoder evaluation, see documentation "Rexroth Connection Cables" in chapter "Select Encoder Cables"

8.8 Using Rexroth IndraDyn Motors

8.8.1 Rexroth IndraDyn H – Synchronous Kit Spindle Motors

When selecting the drive controllers and supply units, make sure that, when using **MBS** motors, the occurring peak power does not cause overvoltage in the DC bus.

Therefore, make sure for your selection that the developed peak power of the motor is smaller than the peak power (or sum of peak powers) of the braking resistors at the DC bus. Take into account that, in particular during operation in the field weakening range, high peak powers occur when control voltage fails.

The assignment table below shows the supply units or drive controllers basically suited for operating MBS motors.

Drive controller or supply unit	IndraDyn H	Notes
	MBS	
HMV01	■	
HMV02	■	
HCS02	-	Capacity P_{BS} of braking resistor is too low for occurring peak power.
HCS03	■	

■ Allowed

- Not allowed

Tab.8-32: Combinations

9 Circuits for the Mains Connection

9.1 General Information

The controls of mains contactor and DC bus short circuit for supply units and drive controllers suggested in this documentation describe the **functional principles**.



The selection of the control and its effects depend on the extent of the functions and the operating sequence of the installation or machine. The selection of the control falls to the installation or machine manufacturer's responsibility.

9.2 Mains Contactor, Bb Contact

The central components in the circuit for the mains connection are:

- Mains contactor
- Bb contact

Mains Contactor

Mains contactors in the power circuit of the mains connection switch the power supply. In the case of error, mains contactors interrupt the energy flow from the supply mains and therewith the power supply of the drive controllers.

When the drive system is supplied via another circuit, e.g. in regenerative form via **permanently** driven motor:

- Integrate this supply in the circuit for the mains connection.
- Take this into account when selecting the drive controllers and additional components.

NOTICE

Risk of fire caused by the "sacrificing behavior" of the ZKS stage!

The "ZKS" input activates the "DC bus short circuit" function, when the 24V control voltage has not been applied and when there isn't any current flowing to the input. This condition can occur in the following situations:

- Failure of 24V control voltage
- Wire break
- Activation of serially connected contacts (e.g. axis limit switches)

If the kinetic energy of the mechanical axis system regenerated when braking is greater than the energy absorption capacity of HLB, the HLB device remains active when braking via ZKS takes place, until it is thermally destroyed (sacrificing behavior). Risk of fire! In this case, braking via ZKS may only come into effect in the case of an emergency (e.g. activation of an axis limit switch causes the mains supply to be cut off and simultaneously causes the 24V supply of the ZKS input to be interrupted).

Install a 24V UPS, if the "sacrificing behavior" of HLB is relevant to your drive system in the case of an emergency. This prevents the braking via ZKS which causes HLB to be destroyed due to the failure of the 24V control voltage. Braking via ZKS then will only take place in cases of emergency.

Switching off the power supply protects the supply units and drive controllers against permanently present error states and damage being caused by the persistent effect of these error states.

Circuits for the Mains Connection

The **mains contactor does not replace overcurrent protection devices connected in the incoming circuit**, but is a functional complement. The mains contactor itself needs overcurrent protection to allow reliably operating it after switch-off processes.

In conjunction with the corresponding "circuit for the mains connection", the mains contactor only switches the DC bus voltage to the drive controllers when they are ready to consume power voltage and when there isn't any error present.

In order that the drive controllers can signal their status, they must be supplied with the 24V control voltage.

The following scenarios are typical cases in which the circuit for the mains connection is to switch off the mains contactor and lead to the power supply being switched off:

- Short circuit at the output of the inverters with error "F8060 Overcurrent in power section"
- Switch-on upon activated DC bus short circuit (ZKS) with error message "F2820 Braking resistor overload"
- Operation at mains voltages outside of the allowed range with error message "F2815 Overvoltage in mains"

 See also firmware documentation "Troubleshooting Guide" which contains the descriptions of the error messages (diagnostic messages).

Bb Contact

The mains contactor has to be controlled depending on the error status of the supply unit or drive controller.

At the control section of the HCS drive controllers and at the supply units, there is an isolated contact available for this purpose (relay contact Rel1) that has been configured as Bb contact in the condition as supplied. When the Bb contact closes, the drive or drive system is ready for power on.

**Danger of consequential damage!**

Make sure that the mains contactor interrupts power supply from the mains when the Bb contact opens.

**Load of Bb contact**

Observe the load capability limits of the Bb contact (see Project Planning Manual "Rexroth IndraDrive, Drive Controllers, Control Sections" for the control section used [connection point X31.1, X31.2]).

Control contactors with AC excitation and contactors exceeding the load capability limits of the involved contact elements (Bb contacts etc.) via contactor relays.

 See also Functional Description of firmware → Power Supply



Suppressor circuit for contactor coil

When the mains contactor is switched off, the contactor coil causes overvoltages. These overvoltages may result in premature failure of the Bb contact.

To attenuate overvoltages, use:

- For contactor coils with **DC voltage**: Overvoltage limiters with diode combination
- For contactor coils with **AC voltage**: Varistors

Avoid varistors and RC elements at contactor coils for DC voltage, because varistors are subject to aging and increase their reverse currents, and RC elements can overload the switching capacity of the Bb contact.

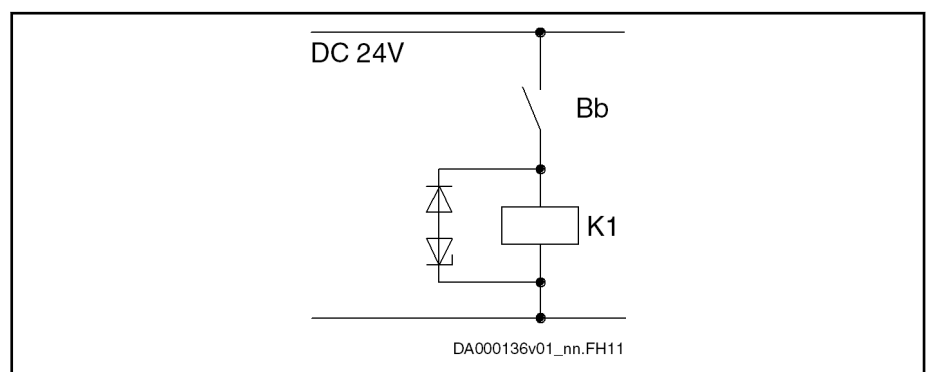

Fig.9-1: Recommended Suppressor Circuit

Switching on the Power Supply

Switch-on sequence

1. Apply 24V control voltage
2. Wait for readiness for operation of the connected components
3. Switch on power supply (e.g. close mains contactor)

Switching off the Power Supply



When mains contactor is switched off frequently

In order to prevent the external mains contactor from being overloaded by the load current in the case of frequent switch-off:

- First switch off the drive, e.g. via drive enable in the master communication
- Then switch off the mains contactor

Switch-off sequence

1. Switch drive off
2. Switch power supply off
3. Switch 24V control voltage off, if required

Using and Arranging the Mains Contactor

For HCS drive controllers of the Rexroth IndraDrive C product range, use an external mains contactor in the main connection for the circuit. Connect the mains contactor electrically between mains filter and mains input (with HCS03 devices and HNK01 mains filters, the mains contactor may be connected electrically before the HNK01 mains filter).

The HMV01.1 supply units of the Rexroth IndraDrive M range have an integrated mains contactor (exception: HMV01.1R-W0120 have no integrated mains contactor and require an external mains contactor).

Circuits for the Mains Connection

⚠ WARNING**Lethal injuries caused by live parts with more than 50 V!**

Design and install the mains connection according to the valid standards.

Observe the protection goals

- Electrical safety
- Mechanical safety in the case of incorrect movements
- Protection against fire

Make sure you can provide evidence of the mechanisms of protection by means of FMEA and hazard analysis.

Make use of the protection by mains contactors in the mains connection.

 For the data for the rating of appropriate mains contactors incl. fuses and cable cross section, see Project Planning Manual "Rexroth IndraDrive Supply Units and Power Sections" → Chapter of the respective device → "Technical Data" → "Basic Data" → table "Data for Mains Voltage Supply".

Using and Arranging an Additional Mains Contactor

When the safety regulations require the circuit interruption in the mains connection to be carried out in redundant form, it is necessary to have additional mains contactors in the mains connection.

Additional mains contactors are allowed at

- HMV supply units
- HCS drive controllers



Place the additional mains contactor **electrically before**:

- Mains filter
- Mains choke
- Mains contactor (integrated or externally installed)
- Mains input of supply unit or drive controller

Observe the following aspect for **PLC programming**:

The additional mains contactor must already have been connected, before the request "power ON" is applied to the supply unit or drive controller.

**Input EIN2**

If the supply unit is operated with an additional mains contactor, the signal at the input EIN2 (X32.4) must be switched to level "L" within the tolerated mains failure time, when this additional mains contactor is switched off.

See also "F2819 Mains failure" in the firmware documentation "Troubleshooting Guide"

At installations with additional mains contactor, there are **2 mains contactors** effective:

1. Integrated or external mains contactor of the supply unit or drive controller which is controlled by the circuit for mains connection
2. Additional mains contactor which is controlled by an independent circuit (e.g., from a PLC)

9.3 Circuits for Mains Connection of Rexroth IndraDrive C Drive Controllers

9.3.1 General Information

The mains contactor connected in the incoming circuit controls the energy flow to the drive controller. This allows separation from the mains in the case of error. The Bb contact at the control section of the drive controller or the Bb contact of the mains supply decisively influences the circuit.

Circuits HCS02 For HCS02 drive controllers, the following circuits for the mains connection are described:

- Control of external mains contactor
- Control of external mains contactor for devices with integrated control voltage supply
- Control of external mains contactor with DC bus resistor unit HLB01.1C

Circuits HCS03 For HCS03 drive controllers, the following circuits for the mains connection are described:

Control of external mains contactor

Configuration "Rel 1" as Bb Contact

Power voltage is only switched to drive system, when the closing of the Bb contact signals readiness for power voltage on.

For this purpose, there is the isolated contact "Rel 1" at the control sections. The behavior of this contact can be configured via the parameter "P-0-0860, Converter configuration":

- Behaves as **converter**, if drive controller is to get supply voltage via mains connection (e.g., for type of mains connection "individual supply" or "central supply")
- Behaves as **inverter**, if drive controller is to get supply voltage via connection DC bus (L+, L-) (e.g., for type of mains connection "central supply" as supplied device)

Include the converter contacts in the circuit in such a way that they make the mains contactor drop out in the case of error (when the contact opens).

You can assign other information to the "Rel 1" contacts of the drive controllers configured as inverters. Via this contact you can, for example, control a second holding brake by entering a signal from "S-0-0398, IDN list of configurable data in signal status word" in parameter "P-0-0300, Digital I/Os, assignment list".

(See also Functional Description of firmware: "Power Supply" and Parameter Description of firmware for P-0-0300 and P-0-0861)

9.3.2 Control of External Mains Contactor for HCS02 and HCS03

General Information

NOTICE

Risk of damage!

Before switching the drive controller on again, wait at least for **300 ms plus the switch-off delay of the mains contactor**.

Circuits for the Mains Connection

**Mains connection HCS02/HCS03 without mains contactor**

You can do without mains contactors in the mains connection, if without mains contactors you achieve the same safety for operator protection as with mains contactors. For this purpose, the following conditions must **simultaneously** apply to the respective application:

- The **safety-related requirements** of the application allow this
- The **local safety regulations** at the site of installation allow this
- **HCS02 or HCS03 drive controllers with integrated 24V supply** (-NNNV design) are used
 - Type of supply "**central supply**"
 - **No** components with DC bus short circuit protection device **ZKS** (e.g. HLB) at the DC bus
 - Passive charging current limitation available via charging resistor in drive controller (HCS02.1E-W0012...0070; HCS03.1E-W0070...0150)
 - The **24V supply** of the drive controllers (e.g. HMS, HMD) operated at the same DC bus must have been applied, **before the mains voltage is switched on**

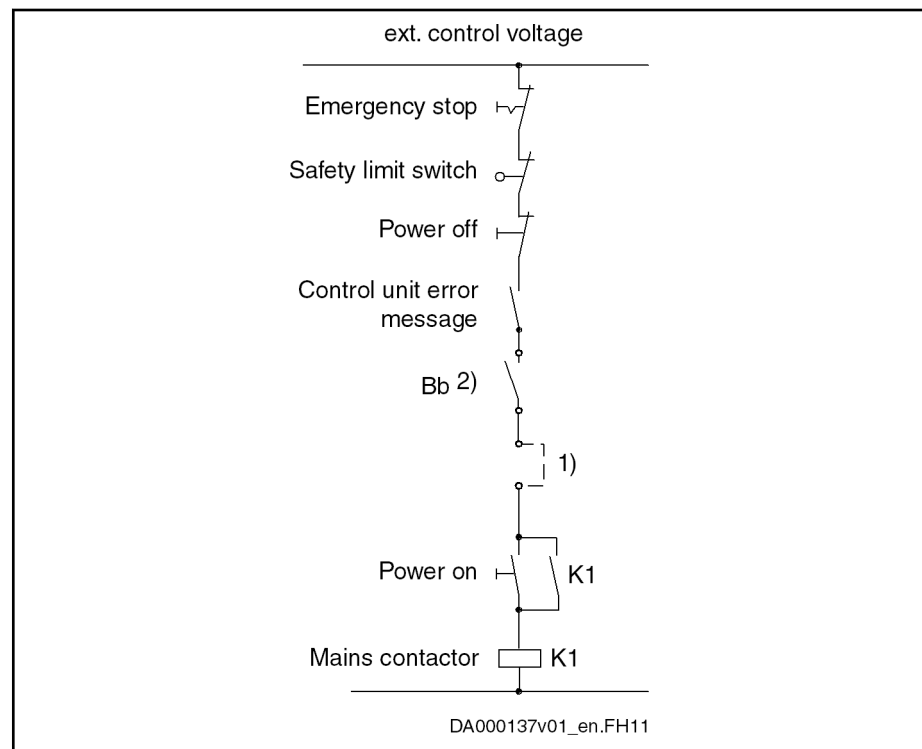
Standard Design for HCS02 and HCS03 Drive Controllers

- 1) Integration of the Bb contacts of other devices and configuration (see "[Configuration Rel 1 as Bb Contact](#)" on page 145)
- 2) Take switching capacity of Bb contact into account (see Project Planning Manual "Rexroth IndraDrive Control Sections"); CSB01.1N-FC control sections have switch contacts with higher switching capacity

Fig. 9-2: Circuit

Design for HCS02 and HCS03 Drive Controllers with Integrated 24V Control Voltage Supply

Drive controllers with integrated 24V control voltage supply (HCS02.1E-...-NNNV, HCS03.1E-...-NNNV) are used, for example, to maintain signal processing for controlled return motion in case the external 24V control voltage supply fails.



The integrated 24V control voltage supply cannot be used for motor brake supply.

To supply the motor brakes, use an external 24V supply.

HCS02, HCS03 With Integrated 24V Control Voltage Supply and CSB01.1N-FC Control Sections

HCS02.1E-...-NNNV and HCS03.1E-...-NNNV drive controllers with CSB01.1N-FC control sections can be operated with control circuits the "external control voltage" of which is up to 1 AC 250 V.



- Observe the allowed switching capacity of the Bb contact of the CSB01.1-FC control sections.

Compared to other control sections, only the CSB01.1-FC control section has a Bb contact with (higher) allowed switching voltage of AC 250 V.

- Until the internal supply voltages are built up and the firmware is actively working in the drive controller, the Bb contact at the control section of the drive controller is open.

Take these times into account for the design of the circuit for the mains connection.

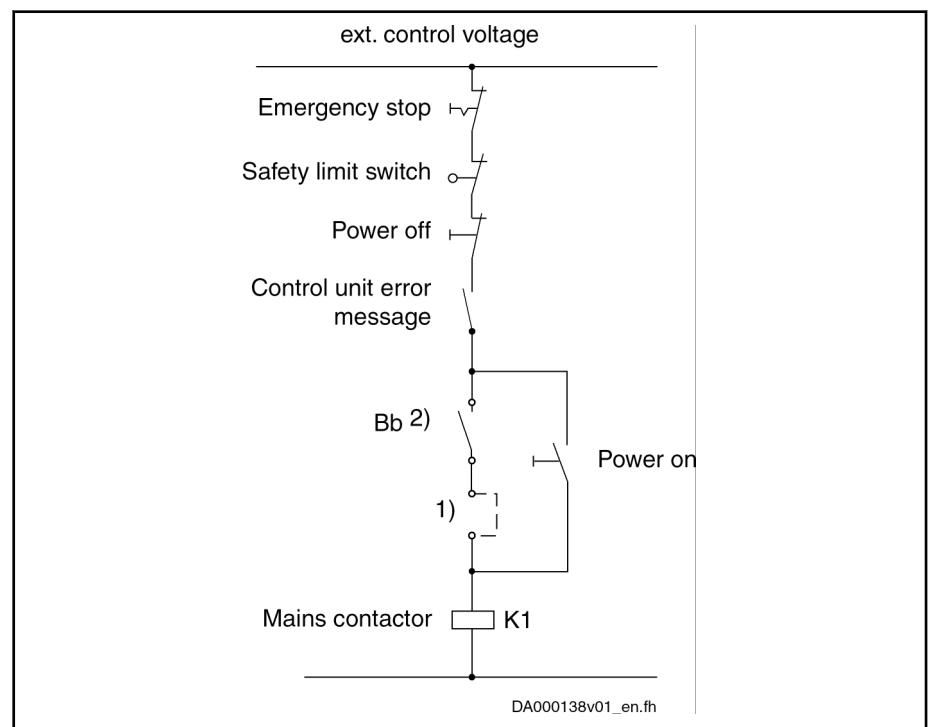

1) Integration of the Bb contacts of other devices and configuration (see ["Configuration Rel 1 as Bb Contact"](#) on page 145)

2) Take switching capacity of Bb contact into account (see Project Planning Manual "Rexroth IndraDrive Control Sections"); CSB01.1N-FC control sections have switch contacts with a high switching capacity

Fig.9-3: Circuit for HCS02.1E-...-NNNV and HCS03.1E-...-NNNV Drive Controllers with CSB01.1N-FC Control Sections

Circuits for the Mains Connection

9.3.3 Circuits HCS02 and HCS03 with DC Bus Resistor Unit HLB01.1C or HLB01.1D

- Application** Use this variant, when
- only motors with permanent magnet excitation are connected
 - motors with permanent magnet excitation and asynchronous motors (induction machines) are connected
- Features** Due to the DC bus short circuit (ZKS), motors with permanent magnet excitation can be decelerated even if the electronic system of the drive is disturbed.

⚠ WARNING

Personal injury caused by uncontrolled axis motion!

The DC bus short circuit protects machines in the case of drive errors. By itself it cannot assume the function of personal protection. In the case of errors in the drive or supply unit, uncontrolled drive motion can occur even when the DC bus short circuit has been activated.

Asynchronous machines do not brake when the DC bus has been short-circuited. Personal injury can occur according to the machine design.

Install additional monitors and protective devices on the installation side.

Suggested Circuit

Connect the **Bb contact of HLB in series** with the Bb contacts of the involved IndraDrive components so that the mains contactor can be opened even if the module bus is defective.

Take the switching capacity of the involved contacts into account (see technical data of the components).



Avoid switching on upon active DC bus short circuit!

Switch the N/O contact K1 before the ZKS1 input so that the DC bus short circuit device is deactivated before the mains contactor K1 switches power to the drive controller.

NOTICE

Risk of damage! Only apply mains voltage, when 24V supply has been applied!

Only switch the mains voltage to HCS02, when the 24V supply has been applied to HLB01 and HCS02.

When the 24V supply has been switched off, the DC bus short circuit device in HLB01 is active and can damage HCS02.

Circuits for the Mains Connection

Suggestion for Control Circuit for the Mains Connection of HCS02 Converters and DC Bus Resistor Units HLB01.1C

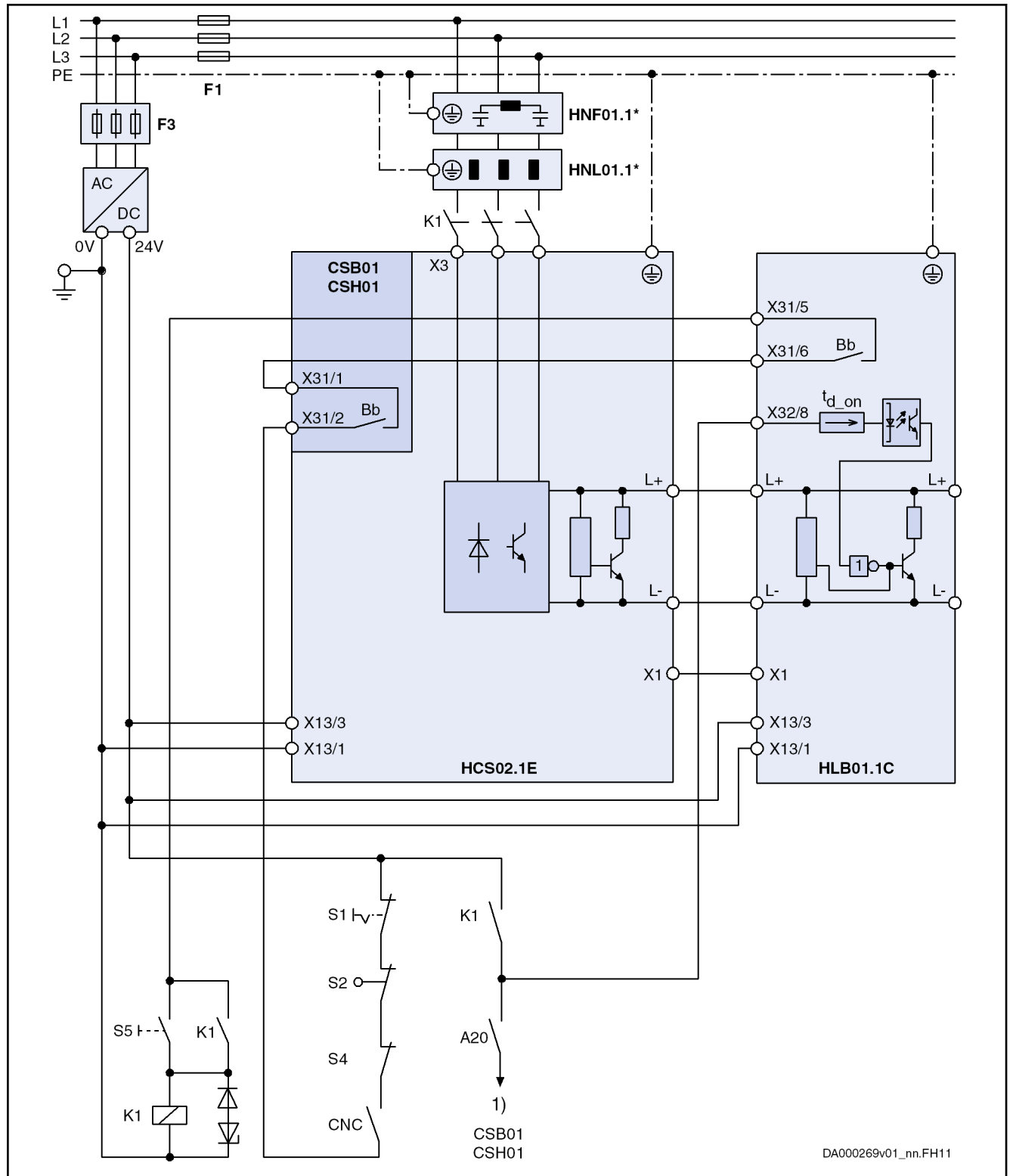

DA000269v01_nn.FH11

- * Optional
- 1) Drive enable (via input at control section or via master communication); depending on parameter "P-0-4028, Device control word"
- A20 Optional contact for drive enable

Circuits for the Mains Connection

Bb	Bb contact (see control section X31.1 and X31.2); Bb contact HLB01
CNC	Lag error message of control unit
F1	Fuse of power supply
F3	Fuse of 24V power supply unit
K1	External mains contactor (OFF delay must be smaller than t_{d_on})
S1	Emergency stop
S2	Axis end position
S4	Power Off
S5	Power On
t_{d_on}	Delay of input X32/8
X1	Module bus
<i>Fig. 9-4:</i>	<i>Control Circuit for Mains Connection of HCS02 and HLB01. 1C</i>

Circuits for the Mains Connection

Suggestion for Control Circuit for the Mains Connection of HCS02 Converters and DC Bus Resistor Units HLB01.1C and Emergency Stop Relay

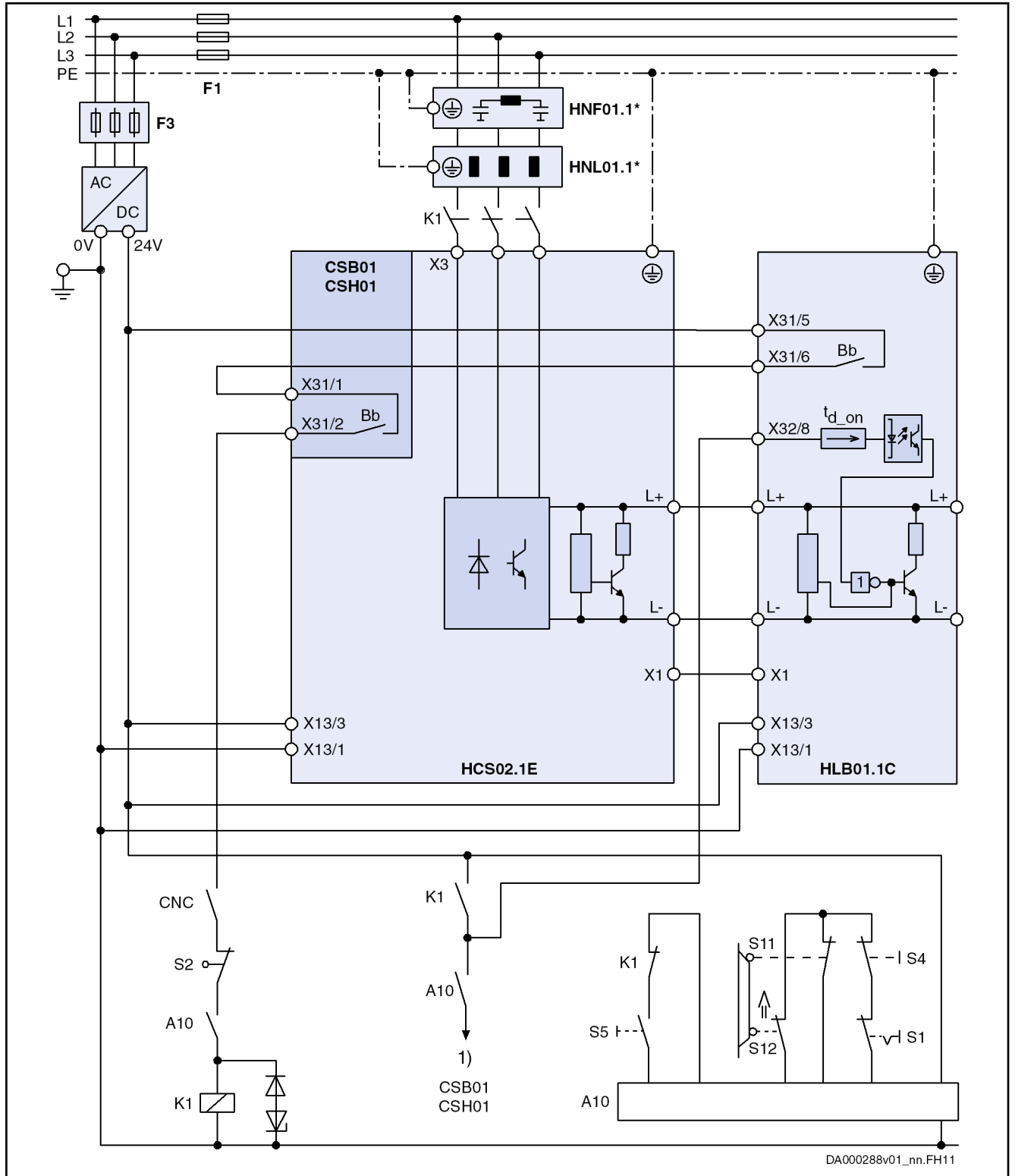

- * Optional
- 1) Drive enable (via input at control section or via master communication); depending on parameter "P-0-4028, Device control word"
- A10 Emergency stop relay (example of circuit; optional design)

Circuits for the Mains Connection

Bb	Bb contact (see control section X31.1 and X31.2); Bb contact HLB01
CNC	Lag error message of control unit
F1	Fuse of power supply
F3	Fuse of 24V power supply unit
K1	External mains contactor (OFF delay must be smaller than t_{d_on})
S1	Emergency stop
S2	Axis end position
S4	Power Off
S5	Power On
t_{d_on}	Delay of input X32/8
X1	Module bus
<i>Fig.9-5:</i>	<i>Control Circuit for Mains Connection of HCS02 and HLB01.1C and Emergency Stop Relay</i>

Circuits for the Mains Connection

Suggestion for Control Circuit for the Mains Connection of HCS03 Converters and DC Bus Resistor Units HLB01.1D

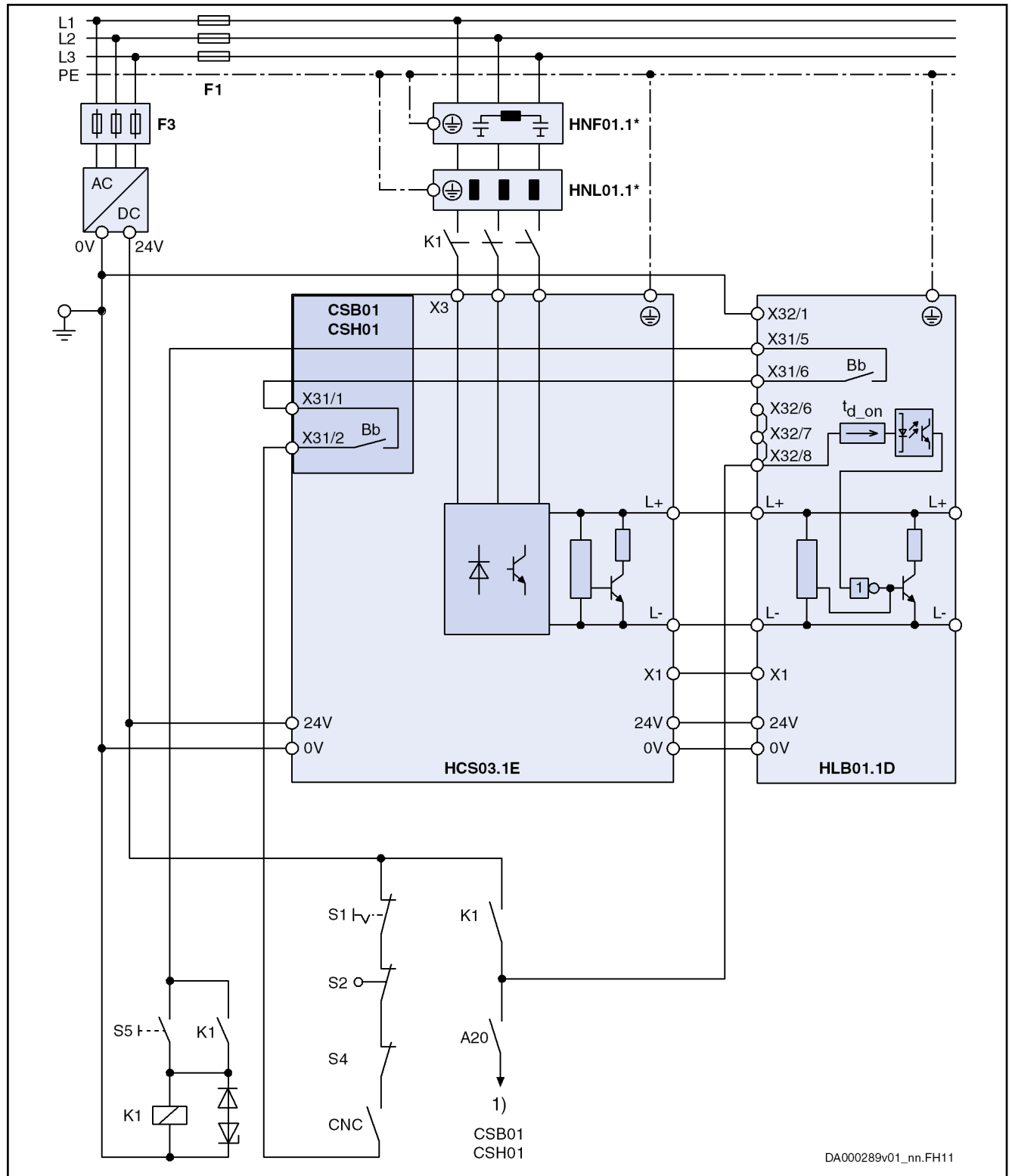

- * Optional; alternatively HNK01
- 1) Drive enable (via input at control section or via master communication); depending on parameter "P-0-4028, Device control word"
- A20 Optional contact for drive enable

Circuits for the Mains Connection

Bb	Bb contact (see control section X31.1 and X31.2); Bb contact HLB01
CNC	Lag error message of control unit
F1	Fuse of power supply
F3	Fuse of 24V power supply unit
K1	External mains contactor (OFF delay must be smaller than t_{d_on})
S1	Emergency stop
S2	Axis end position
S4	Power Off
S5	Power On
t_{d_on}	Delay of input X32/8
X1	Module bus

Fig.9-6: Control Circuit for Mains Connection of HCS03 and HLB01.1D

9.4 Circuits for Mains Connection of Rexroth IndraDrive M Supply Units

9.4.1 General Information

NOTICE

Damage to the supply unit!

At **HMV01.1R** supply units, there must be **at least 10 ms** between the request mains OFF (signal at X32.6 / X32.7) and the disconnection of the mains voltage, so that the energy flow has been interrupted when the disconnection process starts.

You can make sure this order is observed by appropriate switch elements (e.g. by a main switch of the control cabinet with leading auxiliary contact). For this purpose, connect the auxiliary contact in series with mains OFF.



Do not switch on HMV supply units simultaneously!

In the switch-on sequence of the supply unit, the supplying mains is loaded with the current $I_{L_trans_max_on}$ for the purpose of analysis.

During the unloading process, voltage overshoot can occur at the mains components connected in the incoming circuit (e.g. mains filters) due to inductances connected in the incoming circuit, e.g. the leakage inductance of the mains transformer.

With 3 or more HMV supply units at the common supply mains: Switch on supply units one after the other with a time interval of at least 0.5 seconds so that the inrush currents are not added.

Control Circuits HMV

For HMV01.1E, HMV01.1R and HMV02.1R supply units, the following control circuits for the mains connection are described:

- Control circuit for parallel operation HMV01.1E master-slave
- Deceleration in the case of disturbed electronic system of drive
- Deceleration in the case of emergency stop or mains failure
- Control by emergency stop relay with DC bus short circuit
- Control by emergency stop relay without DC bus short circuit
- Control by control unit
- Combination with DC bus resistor unit HLB01.1D

9.4.2 Parallel Operation HMV01

For the type of mains connection "group supply with DC bus connection", use the control circuit master-slave when using HMV01.1E supply units. See the block diagram below:

Control Circuit for Parallel Operation HMV01.1E Master-Slave

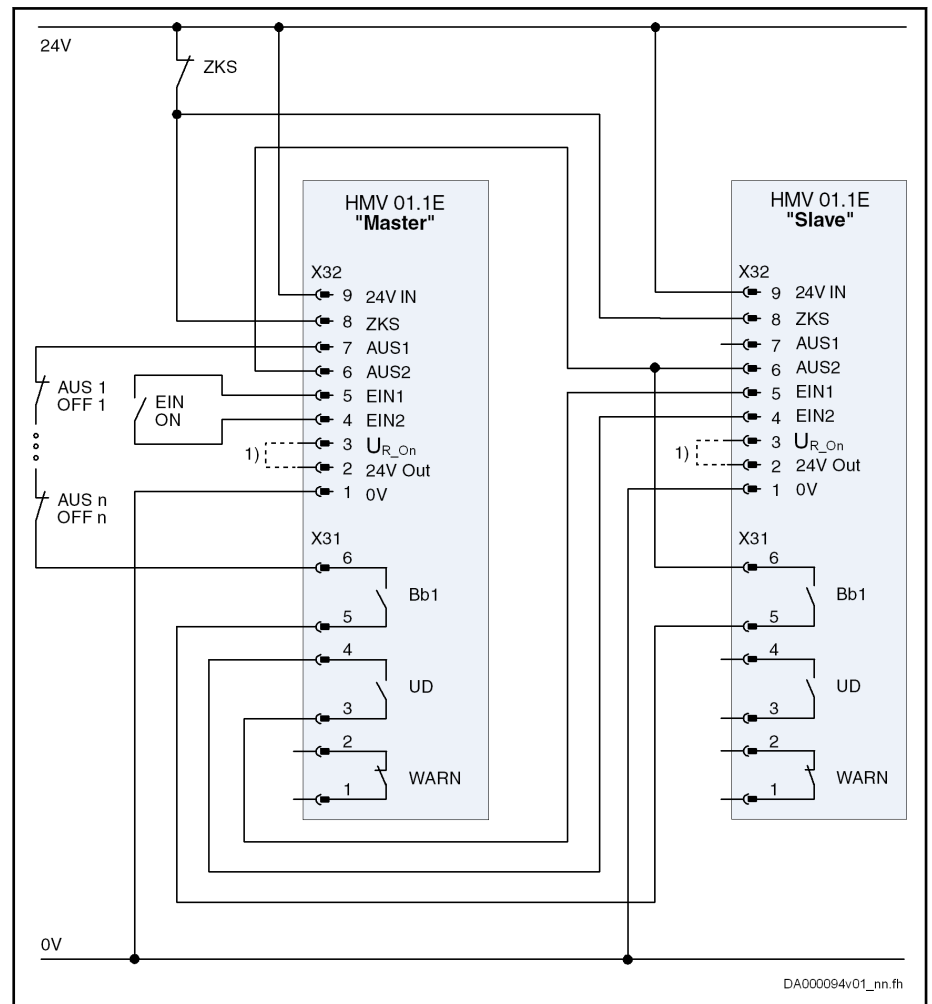

1) Braking resistor switch-on threshold activated
 Fig.9-7: Block Diagram Control Circuit Master-Slave for Parallel Operation HMV01.1E

9.4.3 Deceleration in the Case of Disturbed Electronic System of Drive (DC Bus Short Circuit is Activated)

General Information

DC Bus Short Circuit ZKS

If the electronic system of the drive is disturbed, motors can coast in an uncontrolled way. In these cases, it is possible to short-circuit the DC bus voltage as a measure in addition to shutdown with deceleration of the drives in case the electronic system is disturbed.

In HMV supply units (exception: HMV01.1R-W0120), a circuit has been integrated which can discharge the DC bus as quickly as possible to low voltage. This circuit is called **DC bus short circuit (ZKS)**. With active DC bus short circuit, a low-impedance resistor is connected to the DC bus between L+ and L- via a wear-free switch.

Circuits for the Mains Connection

NOTICE**Risk of fire caused by the "sacrificing behavior" of the ZKS stage!**

The "ZKS" input activates the "DC bus short circuit" function, when the 24V control voltage has not been applied and when there isn't any current flowing to the input. This condition can occur in the following situations:

- Failure of 24V control voltage
- Wire break
- Activation of serially connected contacts (e.g. axis limit switches)

If the kinetic energy of the mechanical axis system regenerated when braking is greater than the energy absorption capacity of HLB, the HLB device remains active when braking via ZKS takes place, until it is thermally destroyed (sacrificing behavior). Risk of fire! In this case, braking via ZKS may only come into effect in the case of an emergency (e.g. activation of an axis limit switch causes the mains supply to be cut off and simultaneously causes the 24V supply of the ZKS input to be interrupted).

Install a 24V UPS, if the "sacrificing behavior" of HLB is relevant to your drive system in the case of an emergency. This prevents the braking via ZKS which causes HLB to be destroyed due to the failure of the 24V control voltage. Braking via ZKS then will only take place in cases of emergency.

**Type of motor and DC bus short circuit**

Asynchronous drives do not decelerate when the DC bus voltage has been short-circuited!

When the DC bus has been short-circuited, motors with permanent magnet excitation generate braking torque and are decelerated.

Control Circuits With DC Bus Short Circuit (ZKS)

If you control the mains contactor in the supply unit by an emergency stop relay and short-circuit the DC bus, you achieve a high degree of safety with little effort. The monitoring functions of the drive system are then used in the most effective way.



DC bus short circuit at HMV without integrated circuit for DC bus short circuit

Use HLB01 DC bus resistor units for DC bus short circuit.

It is not recommended to short-circuit the motor connections.

Application

Use this variant, when

- only motors with permanent magnet excitation are connected
- motors with permanent magnet excitation and asynchronous motors (induction machines) are connected
- the emergency stop switch has to be duplicated or a safety door monitor, for example, is required
- your drive system has an extensive emergency stop circuit



Maximum resistance of control circuit

The pickup current of the auxiliary relay for control of the mains contactor flows via the emergency stop circuit. In order that the mains contactor picks up reliably, the total resistance of the emergency stop circuit taking effect between connections X32/1 and X32/9 has to be less than 45 Ω!

Features

Due to the DC bus short circuit, motors with permanent magnet excitation can be shutdown with deceleration even if the electronic system of the drive is disturbed. In order to trigger a DC bus short circuit in such a case, the Bb contacts **of the drive controllers** have to be connected in series with the control contact and wired in the emergency stop circuit. The DC bus short circuit only takes effect in the case of drive failure. If emergency stop is actuated, asynchronous drives therefore are braking, too.

When the Bb contacts **of the supply unit** are connected in series with the control contact in the emergency stop circuit, the DC bus short circuit is only triggered in the case of a supply unit error.

In the case of emergency stop or when the monitors of the supply unit trigger (e.g. mains failure), the electronic system of the drives shuts them down according to the error reaction that was set.

WARNING

Personal injury caused by uncontrolled axis motion!

The circuit for DC bus short circuit protects machines in the case of drive errors. By itself it cannot assume the function of personal protection. In the case of errors in the drive and supply unit, uncontrolled drive motion can occur even when the DC bus short circuit has been activated.

Asynchronous machines do not brake when the DC bus has been short-circuited. Personal injury can occur according to the machine design.

Use additional monitors and protective devices on the installation side.

Use the "Integrated Safety Technology" by Rexroth.

Circuits for the Mains Connection

Operating Principle When the emergency stop pushbutton is actuated, the mains contactor in the supply unit opens. The emergency stop relay or an auxiliary contact of the mains contactor switches off the drive enable signals. The drives are shut down according to the error reaction set in the drive controller.

The mains contactor is switched off and the DC bus short circuit (ZKS) takes effect, when

- the supply unit (Bb1 contact) outputs a drive error message
- the control unit (CNC contact) outputs an error message
- the limit switch (S2) is passed

Circuits for the Mains Connection

Control Circuit "DC Bus Short Circuit (ZKS) in the Case of Disturbed Electronic System of Drive" for the Mains Connection of HMV01.1E Supply Units With Integrated Mains Contactor (e.g. HMV01.1E-W0030, -W0070, -W0120)

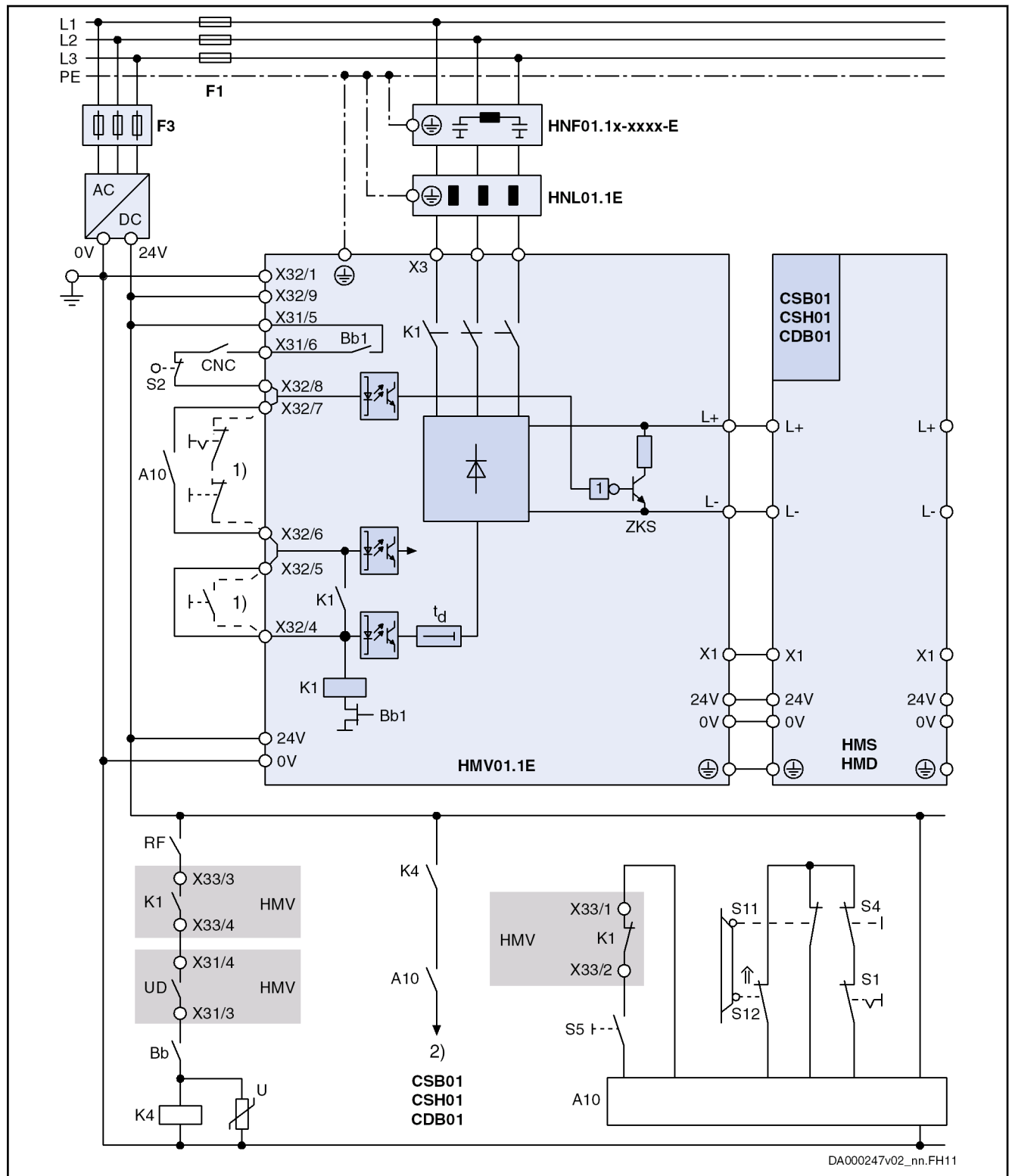

DA000247v02_nn.FH11

- F1 Fuse of power supply
- F3 Fuse of 24V power supply unit
- 1) Control of K1, if A10 is not used

Circuits for the Mains Connection

2)	Drive enable (via input at control section or via master communication); see also parameter "P-0-4028, Device control word"
A10	Emergency stop relay (example of circuit)
Bb1	Readiness for operation of supply unit
Bb	Readiness for operation of drive controllers (see control section X31.1 and X31.2)
CNC	Lag error message of control unit
K1	Integrated mains contactor
K4	Control of drive enable
S1	Emergency stop
S2	Axis end position
S4	Power Off
S5	Power On
S11, S12	Safety door monitor
ZKS	DC bus short circuit
HNL, HNF	Optional, depending on the application
<i>Fig. 9-8:</i>	<i>Control Circuit DC Bus Short Circuit (ZKS) in the Case of Disturbed Electronic System of Drive for HMV01.1E Supply Units With Integrated Mains Contactor</i>

Circuits for the Mains Connection

Control Circuit "DC Bus Short Circuit (ZKS) in the Case of Disturbed Electronic System of Drive" for the Mains Connection of HMV01.1R Supply Units With Integrated Mains Contactor (e.g. HMV01.1R-W0018, -W0045, -W0065)

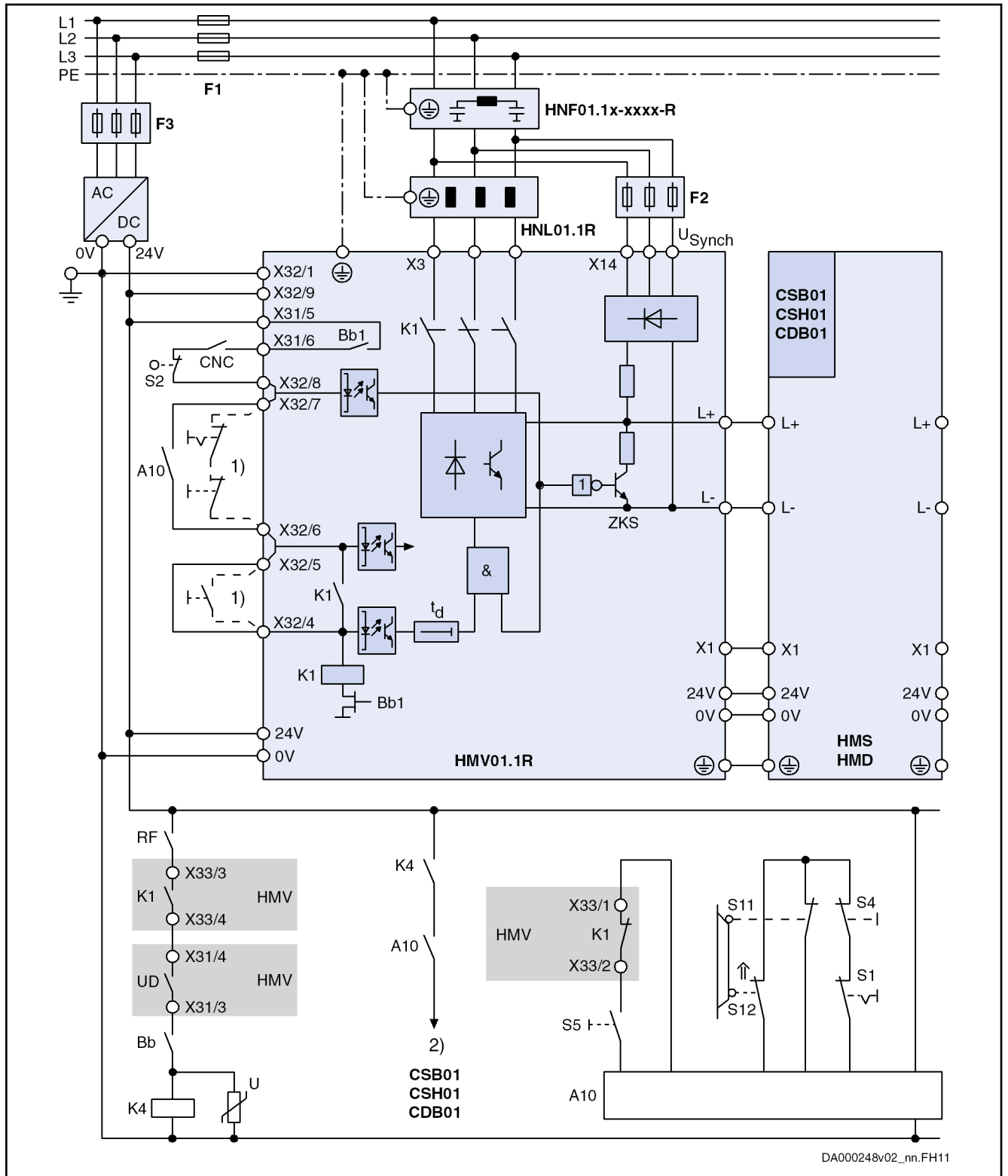

DA000248v02_nn.FH11

- F1 Fuse of power supply
- F2 Fuse of synchronization connection X14
- F3 Fuse of 24V power supply unit

Circuits for the Mains Connection

1)	Control of K1, if A10 is not used
2)	Drive enable (via input at control section or via master communication); see also parameter "P-0-4028, Device control word"
A10	Emergency stop relay (example of circuit)
Bb1	Readiness for operation of supply unit
Bb	Readiness for operation of drive controllers (see control section X31.1 and X31.2)
CNC	Lag error message of control unit
K1	Integrated mains contactor
K4	Control of drive enable
S1	Emergency stop
S2	Axis end position
S4	Power Off
S5	Power On
S11, S12	Safety door monitor
ZKS	DC bus short circuit
<i>Fig. 9-9:</i>	<i>Control Circuit DC Bus Short Circuit (ZKS) in the Case of Disturbed Electronic System of Drive for HMV01.1R Supply Units With Integrated Mains Contactor</i>

Operating Principle With
HLB01.1D

When the emergency stop pushbutton is actuated, the mains contactor in the supply unit drops out. The emergency stop relay or an auxiliary contact of the mains contactor switches off the drive enable signals. The drives are shut down according to the error reaction set in the drive controller.

The mains contactor is switched off and the DC bus short circuit (ZKS) takes effect in HMV and HLB, when

- the supply unit (Bb1 contact) outputs a drive error message
- the control unit (CNC contact) outputs an error message
- the limit switch (S2) is passed

NOTICE**Risk of damage to the device!**

Establish connection from **HMV_X32/8** to **HLB_X32/7**.

This avoids energy from the mains connection being supplied and the DC bus short circuit protection device of the DC bus resistor unit HLB being simultaneously active.

Circuits for the Mains Connection

Control Circuit "DC Bus Short Circuit (ZKS) at HMV and HLB in Case of Disturbed Electronic System of Drive" for Mains Connection of HMV01.1R With Integrated Mains Contactor (e.g. HMV01.1R-W0018, -45, -65) and HLB01.1D

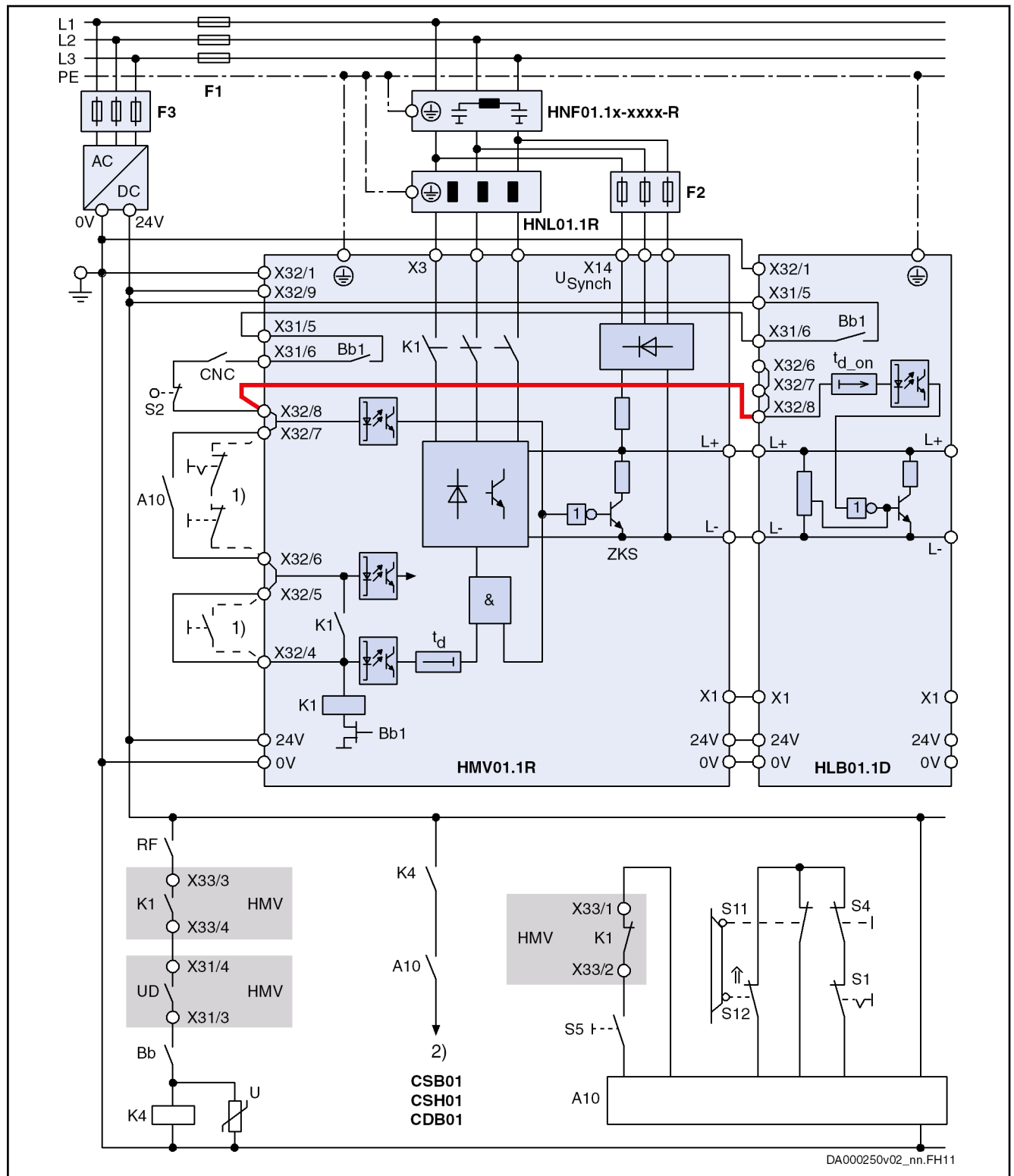

DA000250v02_nn.FH11

- F1 Fuse of power supply
- F2 Fuse of synchronization connection X14
- F3 Fuse of 24V power supply unit
- 1) Control of K1, if A10 is not used

Circuits for the Mains Connection

2)	Drive enable (via input at control section or via master communication); see also parameter "P-0-4028, Device control word"
A10	Emergency stop relay (example of circuit)
Bb1	Readiness for operation of supply unit
Bb	Readiness for operation of drive controllers (see control section X31.1 and X31.2)
CNC	Lag error message of control unit
K1	Integrated mains contactor
K4	Control of drive enable
S1	Emergency stop
S2	Axis end position
S4	Power Off
S5	Power On
S11, S12	Safety door monitor
ZKS	DC bus short circuit

Fig.9-10: Control Circuit DC Bus Short Circuit (ZKS) at HMV and HLB in the Case of Disturbed Electronic System of Drive for HMV01.1R Supply Units With Integrated Mains Contactor and HLB01.1D

Circuits for the Mains Connection

Suggestion for Control Circuit "HMV and HLB With DC Bus Short Circuit (ZKS) in Case of Disturbed Electronic System of Drive" for Mains Connection of HMV01.1R-W0120 With External Mains Contactor and HLB01.1D

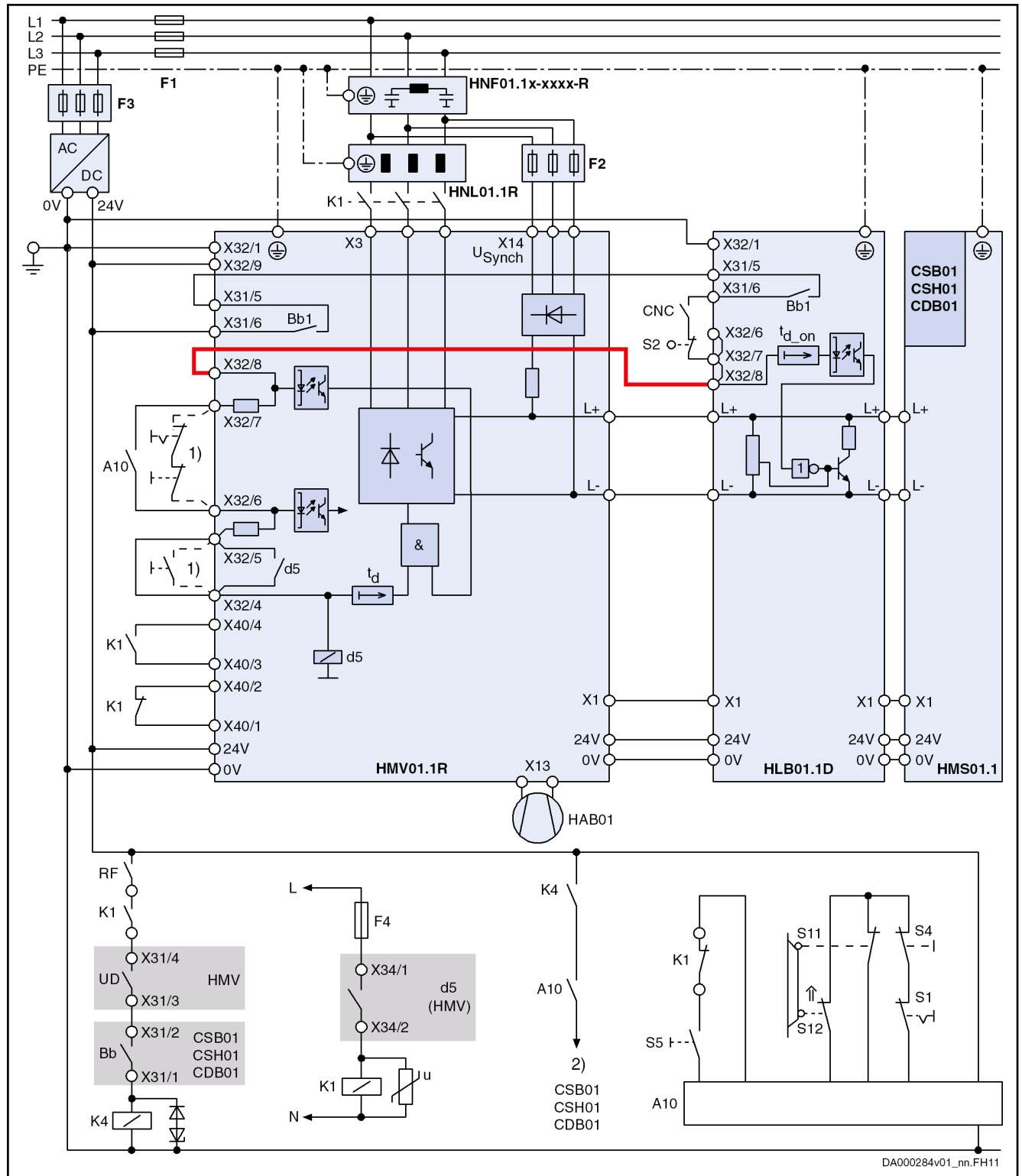

DA000284v01_nm.FH11

- 1) Control of K1, if A10 is not used
- 2) Drive enable (via input at control section or via master communication); depending on parameter "P-0-4028, Device control word"
- A10 Emergency stop relay (example of circuit; optional design)

Circuits for the Mains Connection

Bb	Readiness for operation of drive controllers (control section X31.1 and X31.2)
Bb1	Readiness for operation of supply unit
CNC	Lag error message of control unit
d5	Internal relay in supply unit
F1	Fuse of power supply
F2	Fuse of synchronization connection X14
F3	Fuse of 24V power supply unit
F4	Fuse 2 A
HAB01	External blower unit
HLB01.1D	DC bus resistor unit
K1	External mains contactor
K4	Control of drive enable
L, N	AC supply mains contactor
S1	Emergency stop
S2	Axis end position
S4	Power Off
S5	Power On
S11, S12	Safety door monitor
X1	Module bus
ZKS	DC bus short circuit
t_{d_on}	Switch-on delay DC bus short circuit
t_d	Delay in HMV

Fig.9-11: Control Circuit HMV and HLB With DC Bus Short Circuit (ZKS) in the Case of Disturbed Electronic System of Drive for HMV01.1R-W0120 Supply Units With External Mains Contactor and HLB01.1D



Observe Off delay and pick-up delay of K1!

Off delay K1:

Select K1 mains contactors with an Off delay shorter than the On delay t_{d_on} of the DC bus short circuit device. Otherwise, the DC bus short circuit device switches on with applied mains voltage and causes tripped fuse (F1) or damage to the supply unit.

Circuits for overvoltage protection increase the Off delay. Observe the data of the selected mains contactor!

Pick-up delay K1:

Select K1 mains contactors with a pick-up delay of less than 100 ms. Otherwise, the error message F2835 will be generated.

9.4.4 Deceleration in the Case of Emergency Stop or Mains Failure

General Information

In the case of emergency stop or mains failures, the drives normally are shut-down by drive control.

In the case of emergency stop or when the drive-internal monitors trigger, the drive control inputs the command value "zero". The drives are thereby decelerating in a controlled way with maximum torque.

In some applications (e.g. electronically coupled gear cutting machines) it is required that the drive shutdown is controlled by the control unit in the case of emergency stop or mains failures. In the case of emergency stop or when the drive-internal monitors trigger, the control unit decelerates the drives in a position-controlled way. In such applications, the **DC bus short circuit must not be activated**.

For further details, see the Functional Description of the firmware under the index entry "Best possible deceleration".

Control Circuit "Position-Controlled Deceleration by the Control Unit" without DC Bus Short Circuit (ZKS)

If the mains contactor is controlled by the control unit, the drive, in the case of emergency stop or when the drive-internal monitor triggers, can be decelerated in a position-controlled way by a control unit.

Application This kind of mains contactor control is mainly used for electronically coupled drives that are decelerated synchronously even in the case of mains failure.

Features The DC bus voltage is not short-circuited so that there is energy available for position-controlled deceleration of the drives.



The energy stored in the DC bus or the regenerated energy has to be greater than the energy required for excitation of asynchronous machines or for return motions.

The parameter "Activation of NC reaction on error" has to be set accordingly in the drive controller (P-0-0117, bit 0 = 1).

In the case of emergency stop or when the monitors of the supply unit trigger (e.g. mains failure), the drives are decelerated in a position-controlled way by the positioning control.

Operating Principle When the emergency stop circuit opens or the monitors of the supply unit trigger (e.g. mains failure), the mains contactor in the supply unit drops out.

For drives with sercos interface, the error is signaled to the control unit and the drives can be decelerated in a position-controlled way.

For drives without sercos interface, the control unit has to evaluate the UD contact. When the UD contact triggers, the control unit must decelerate the drives.

NOTICE

Damage to machines caused by unbraked coasting to stop of the drives in case DC bus voltage is too low!

The control unit should evaluate the UD contact and decelerate the drives when the contact triggers.

Circuits for the Mains Connection

Control Circuit "Position-Controlled Shutdown by the Control Unit" for the Mains Connection of HMV01.1R Supply Units With Integrated Mains Contactor (e.g. HMV01.1R-W0018, -W0045, -W0065)

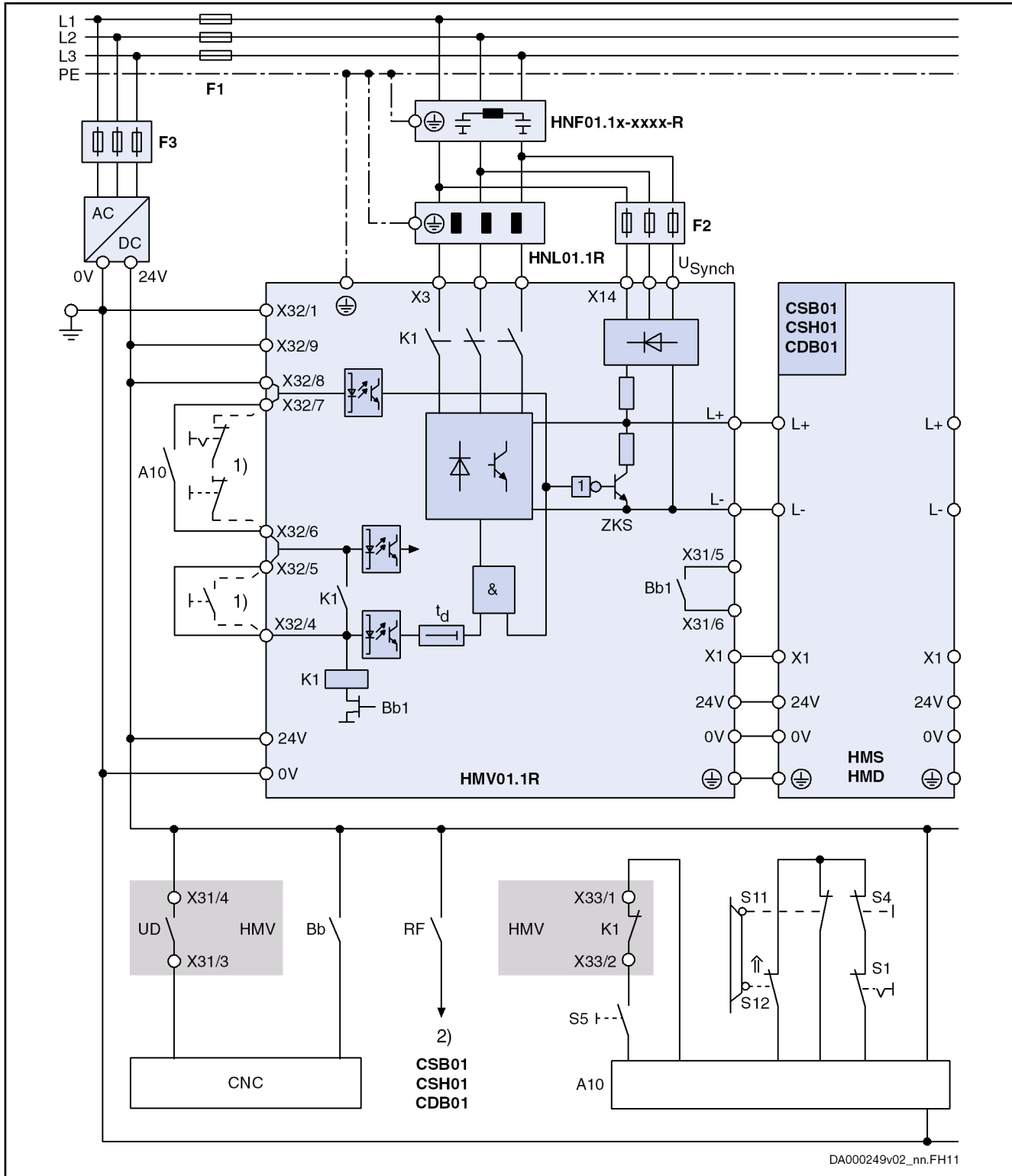

DA000249v02_nn.FH11

- F1 Fuse of power supply
- F2 Fuse of synchronization connection X14
- F3 Fuse of 24V power supply unit
- 1) Control of K1, if A10 is not used

Circuits for the Mains Connection

2)	Drive enable (via input at control section or via master communication); see also parameter "P-0-4028, Device control word"
A10	Emergency stop relay (example of circuit)
Bb1	Readiness for operation of supply unit
Bb	Readiness for operation of drive controllers (see control section X31.1 and X31.2)
CNC	Control unit of installation
K1	Integrated mains contactor
K4	Control of drive enable
S1	Emergency stop
S2	Axis end position
S4	Power Off
S5	Power On
S11, S12	Safety door monitor
ZKS	DC bus short circuit

Fig. 9-12: Control Circuit Without DC Bus Short Circuit (ZKS), Position-Controlled Shutdown by the Control Unit for HMV01.1R Supply Units With Integrated Mains Contactor

Control Circuit Emergency Stop Relay without DC Bus Short Circuit (ZKS)

Application	<ul style="list-style-type: none"> • If unbraked coasting to stop of the drives does not damage the installation. • If only asynchronous motors are connected to the supply unit. • If the end positions of the feed axes have been sufficiently cushioned. • If external braking devices are used.
Features	<p>The DC bus voltage is not short-circuited.</p> <p>In the case of emergency stop or when the monitors of the supply unit trigger (e.g. mains failure), the drives are shut down according to the error reaction set in the drive controller.</p>
Operating Principle	<p>When the emergency stop circuit opens, the mains contactor in the supply unit drops out immediately. The emergency stop relay or an auxiliary contact of the mains contactor switches off the drive enable signals. The drives are shut down according to the error reaction set in the drive controller.</p>

NOTICE

Damage to machines caused by unbraked coasting to stop of the drives in case their electronic system is disturbed!

Use motors with mechanical brake (a holding brake mustn't be used as service brake).

Sufficiently cushion end positions of feed axes.

Circuits for the Mains Connection

Example Control Circuit "Without DC Bus Short Circuit (ZKS)" for the Mains Connection of HMV01.1E Supply Units With Integrated Mains Contactor (e.g. HMV01.1E-W0030, -W0070, -W0120)

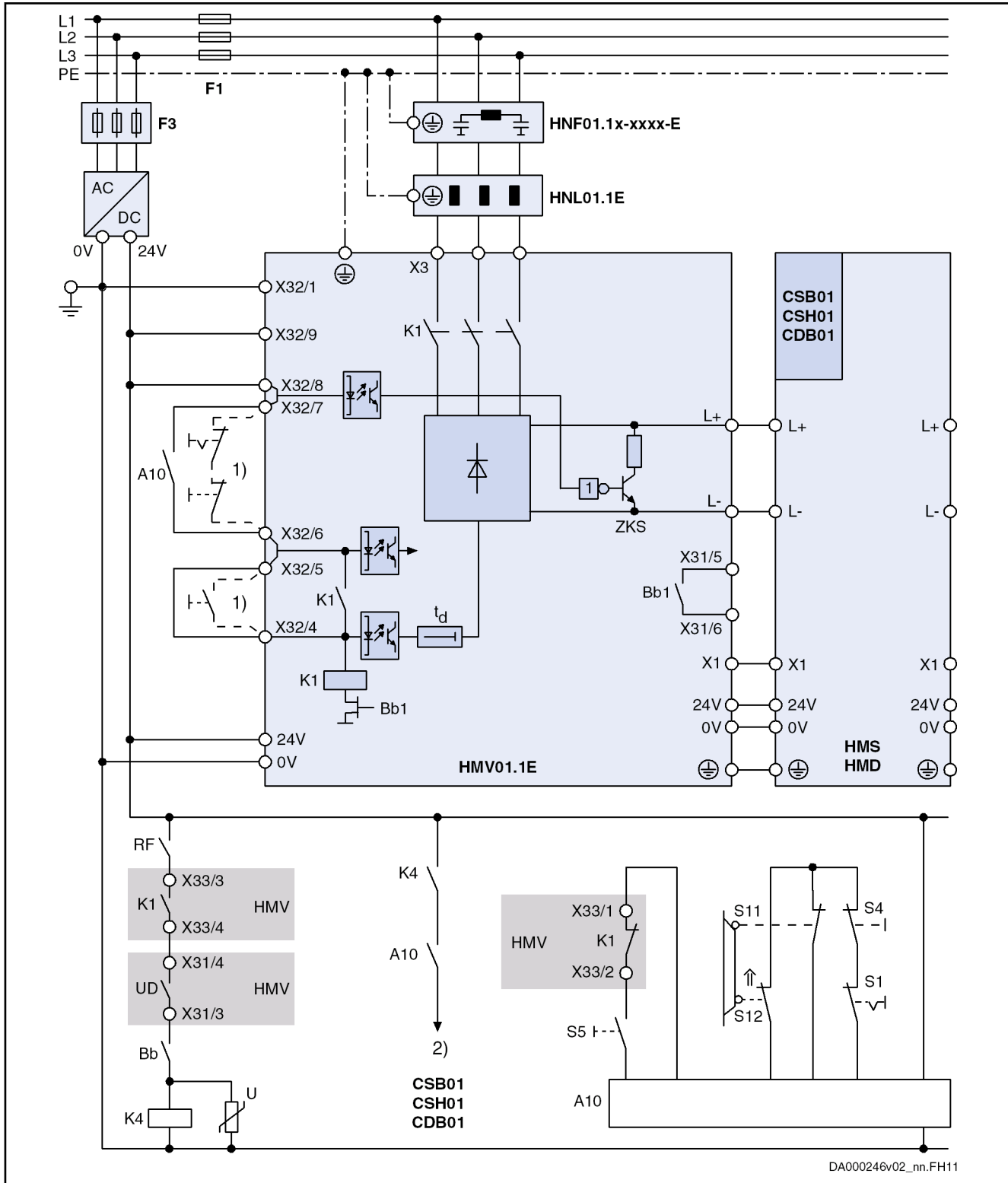

DA000246v02_nn.FH11

- F1 Fuse of power supply
- F3 Fuse of 24V power supply unit
- 1) Control of K1, if A10 is not used

Circuits for the Mains Connection

2)	Drive enable (via input at control section or via master communication); see also parameter "P-0-4028, Device control word"
A10	Emergency stop relay (example of circuit)
Bb1	Readiness for operation of supply unit
Bb	Readiness for operation of drive controllers (see control section X31.1 and X31.2)
K1	Integrated mains contactor
K4	Control of drive enable
S1	Emergency stop
S4	Power Off
S5	Power On
S11, S12	Safety door monitor
ZKS	DC bus short circuit
HNL, HNF	Optional, depending on the application

Fig.9-13: Control Circuit Without DC Bus Short Circuit (ZKS) for HMV01.1E Supply Units With Integrated Mains Contactor

Circuits for the Mains Connection

Example Control Circuit "Without DC Bus Short Circuit (ZKS)" for the Mains Connection of HMV01.1R Supply Units With Integrated Mains Contactor (e.g. HMV01.1R-W0018, -W0045, -W0065)

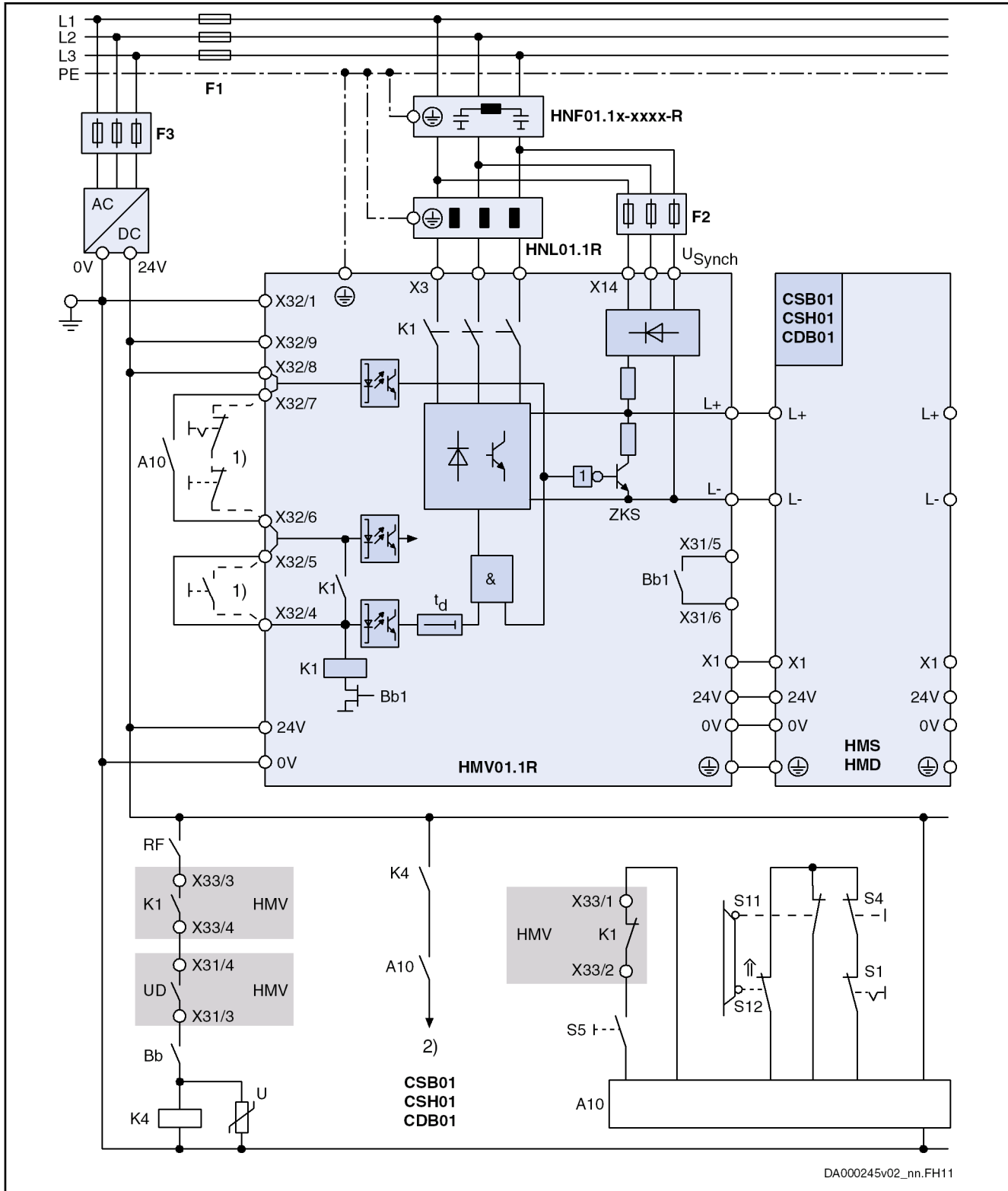

DA000245v02_nn.FH11

- F1 Fuse of power supply
- F2 Fuse of synchronization connection X14
- F3 Fuse of 24V power supply unit
- 1) Control of K1, if A10 is not used

Circuits for the Mains Connection

2)	Drive enable (via input at control section or via master communication); see parameter "P-0-4028, Device control word"
A10	Emergency stop relay (example of circuit)
Bb1	Readiness for operation of supply unit
Bb	Readiness for operation of drive controllers (see control section X31.1 and X31.2)
K1	Integrated mains contactor
K4	Control of drive enable
S1	Emergency stop
S4	Power Off
S5	Power On
S11, S12	Safety door monitor
ZKS	DC bus short circuit

Fig.9-14: Control Circuit Without DC Bus Short Circuit (ZKS) for HMV01.1R Supply Units With Integrated Mains Contactor

Circuits for the Mains Connection

Example Control Circuit "Without DC Bus Short Circuit (ZKS)" for the Mains Connection of HMV01.1R Supply Units Without Integrated Mains Contactor (e.g. HMV01.1R-W0120)

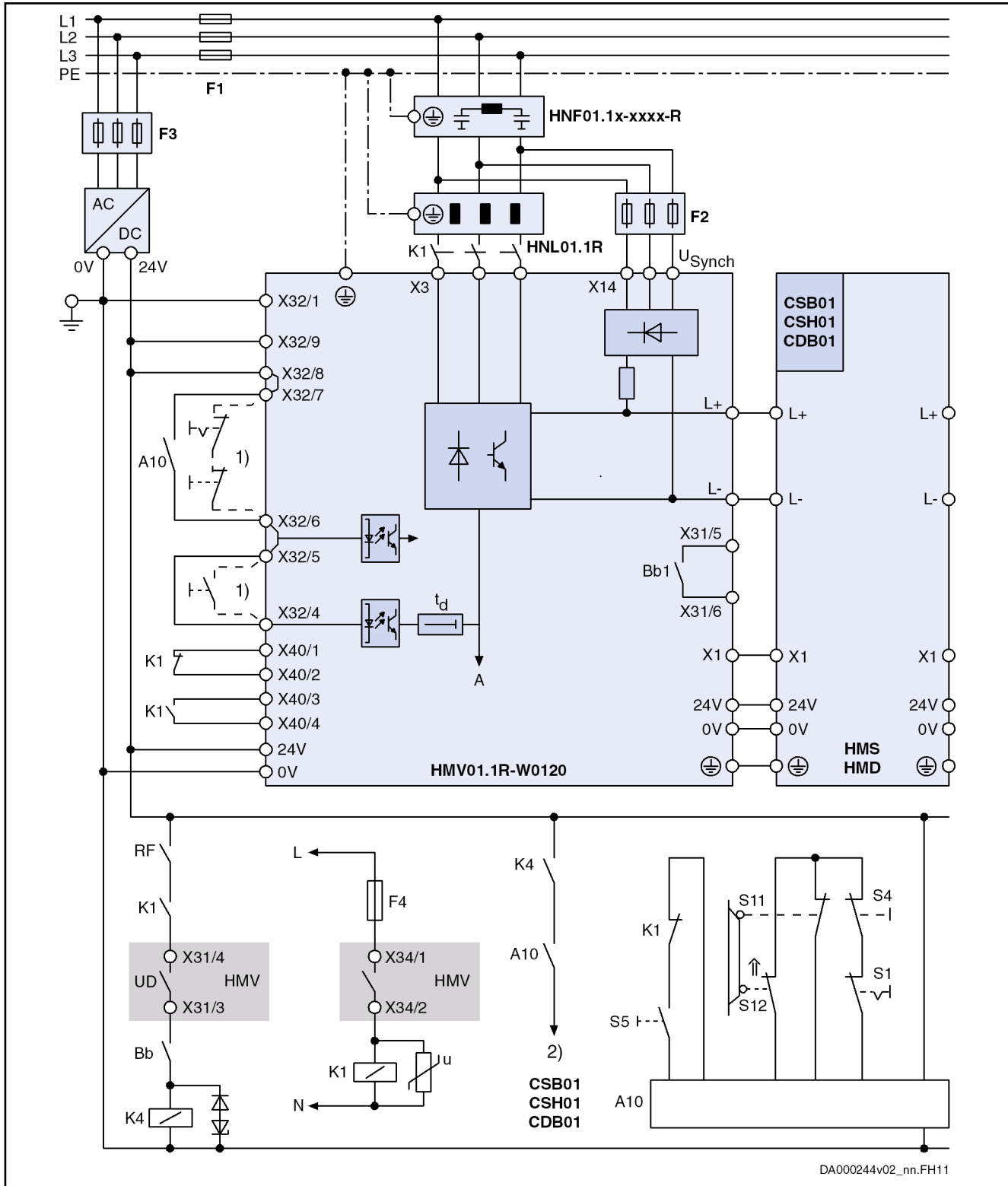

DA000244v02_nn.FH11

- F1 Fuse of power supply
- F2 Fuse of synchronization connection X14 (see Project Planning Manual "Rexroth IndraDrive Supply Units and Power Sections")
- F3 Fuse of 24V power supply unit

Circuits for the Mains Connection

F4	Fuse of contactor control X34 (see Project Planning Manual "Rexroth IndraDrive Supply Units and Power Sections")
1)	Control of K1, if A10 is not used
2)	Drive enable (via input at control section or via master communication); see also parameter "P-0-4028, Device control word"
A10	Emergency stop relay (example of circuit)
Bb1	Readiness for operation of supply unit
Bb	Readiness for operation of drive controllers (see control section X31.1 and X31.2)
K1	Mains contactor
K4	Control of drive enable
L, N	AC supply mains contactor
S1	Emergency stop
S4	Power Off
S5	Power On
S11, S12	Safety door monitor

Fig. 9-15: Control Circuit Without DC Bus Short Circuit (ZKS) for HMV01.1R Supply Units Without Integrated Mains Contactor

**Observe Off delay and pick-up delay of K1!****Off delay K1:**

Select K1 mains contactors with an Off delay shorter than the On delay t_{d_on} of the DC bus short circuit device. Otherwise, the DC bus short circuit device switches on with applied mains voltage and causes tripped fuse (F1) or damage to the supply unit.

Circuits for overvoltage protection increase the Off delay. Observe the data of the selected mains contactor!

Pick-up delay K1:

Select K1 mains contactors with a pick-up delay of less than 100 ms. Otherwise, the error message F2835 will be generated.

Circuits for the Mains Connection

Example Control Circuit "Without DC Bus Short Circuit (ZKS)" for the Mains Connection of HMV02.1R Supply Units With Integrated Mains Contactor (e.g. HMV02.1R-W0015)

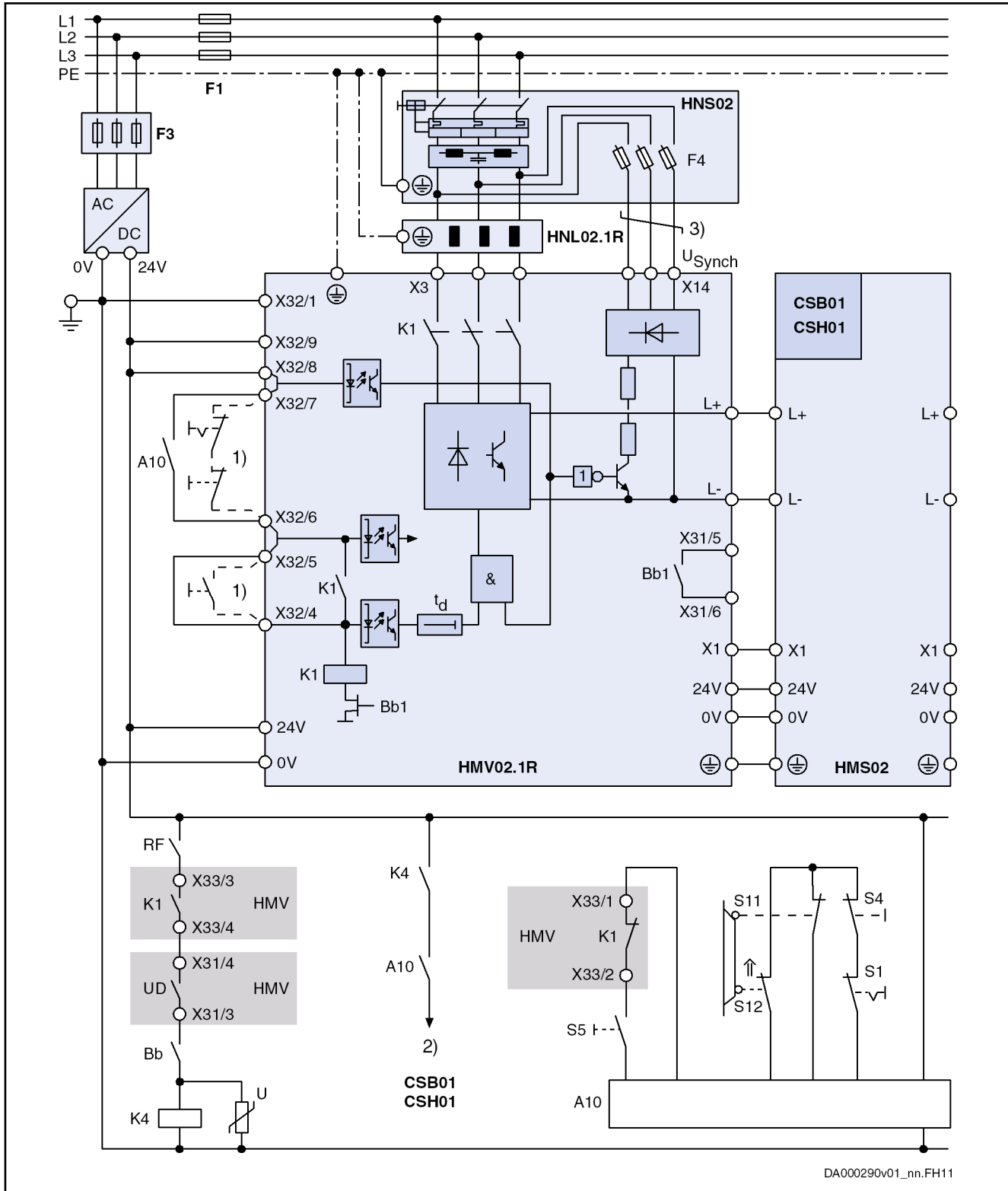

DA000290v01_nn.FH11

- F1 Fuse of power supply
- F3 Fuse of 24V power supply unit
- F4 Fuse of synchronization connection X14 (integrated in HNS02 mains filter)

Circuits for the Mains Connection

1)	Control of K1, if A10 is not used
2)	Drive enable (via input at control section or via master communication); see parameter "P-0-4028, Device control word"
3)	Twist wires
A10	Emergency stop relay (example of circuit)
Bb1	Readiness for operation of supply unit
Bb	Readiness for operation of drive controllers (see control section X31.1 and X31.2)
K1	Integrated mains contactor
K4	Control of drive enable
S1	Emergency stop
S4	Power Off
S5	Power On
S11, S12	Safety door monitor
ZKS	DC bus short circuit

Fig. 9-16: Control Circuit Without DC Bus Short Circuit (ZKS) for HMV02.1R Supply Units With Integrated Mains Contactor

9.4.5 Signal Sequences When Switching HMV Supply Units ON and OFF

Switching On

NOTICE

Risk of damage to the supply units when they are switched on simultaneously!

With 3 or more HMV supply units at common supply mains: Switch on supply units one after the other with a **time interval of at least 0.5 seconds** so that the inrush currents are not added.

In the switch-on sequence of the supply unit, the supplying mains is loaded with the current $I_{L_trans_max_on}$ for the purpose of analysis. During the unloading process, voltage overshoot can occur at the mains components connected in the incoming circuit (e.g. mains filters) due to inductances connected in the incoming circuit, e.g. the leakage inductance of the mains transformer.

Circuits for the Mains Connection

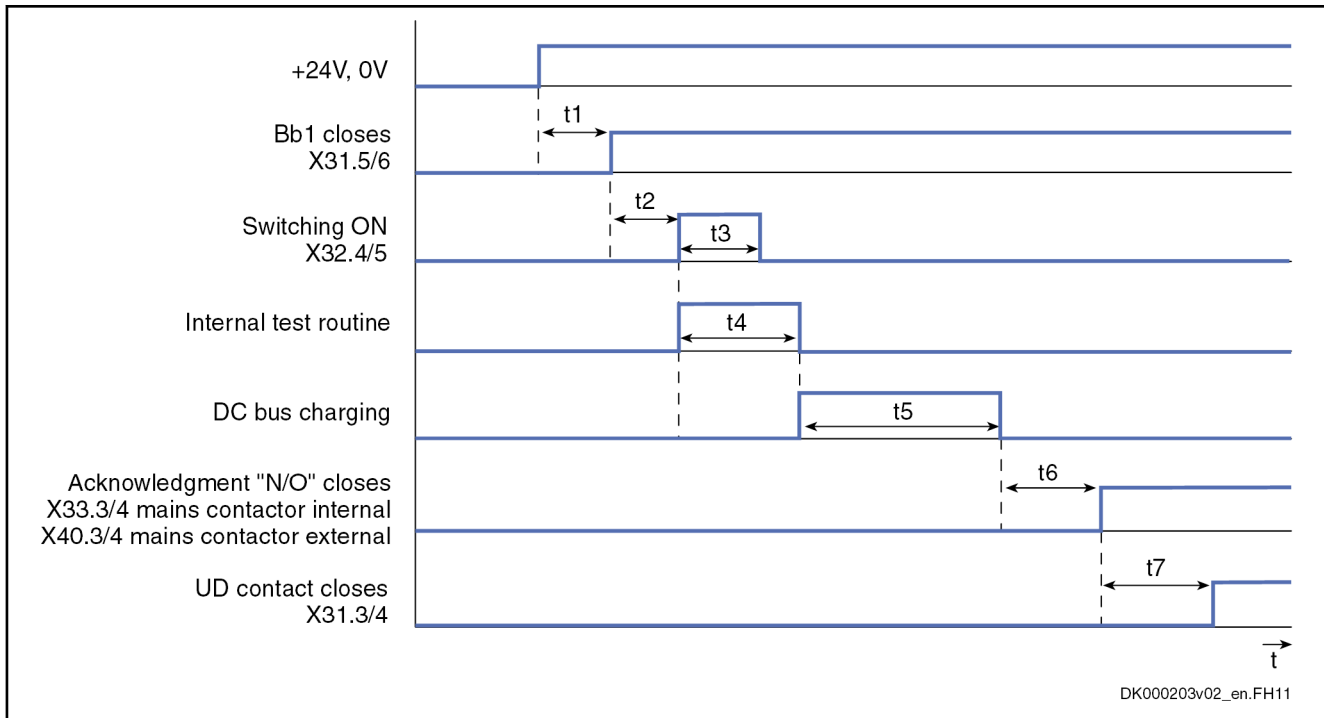

- t1 5.2 s; time for internal booting until Bb1 contact closes
- t2 Time can be set by the user. Take the time into account which is required for run-up of all devices connected to the module bus. This time depends on the control unit or the machine.
- t3 At least 250 ms; switch-on pulse
- t4 500 ms; time for internal test routines before the DC bus is charged
- t5 Time depends on DC bus capacitance (internal, external) and mains voltage
- t6 500 ms; delay time until mains contactor closes
- t7 Maximum 200 ms; depends on device (ON delay of mains contactor)

Fig.9-17: Signal Sequences When Switching On

Involved Connection Points

See "Rexroth IndraDrive Supply Units and Power Sections" → chapter "Functions and Connection Points"

Switching Off

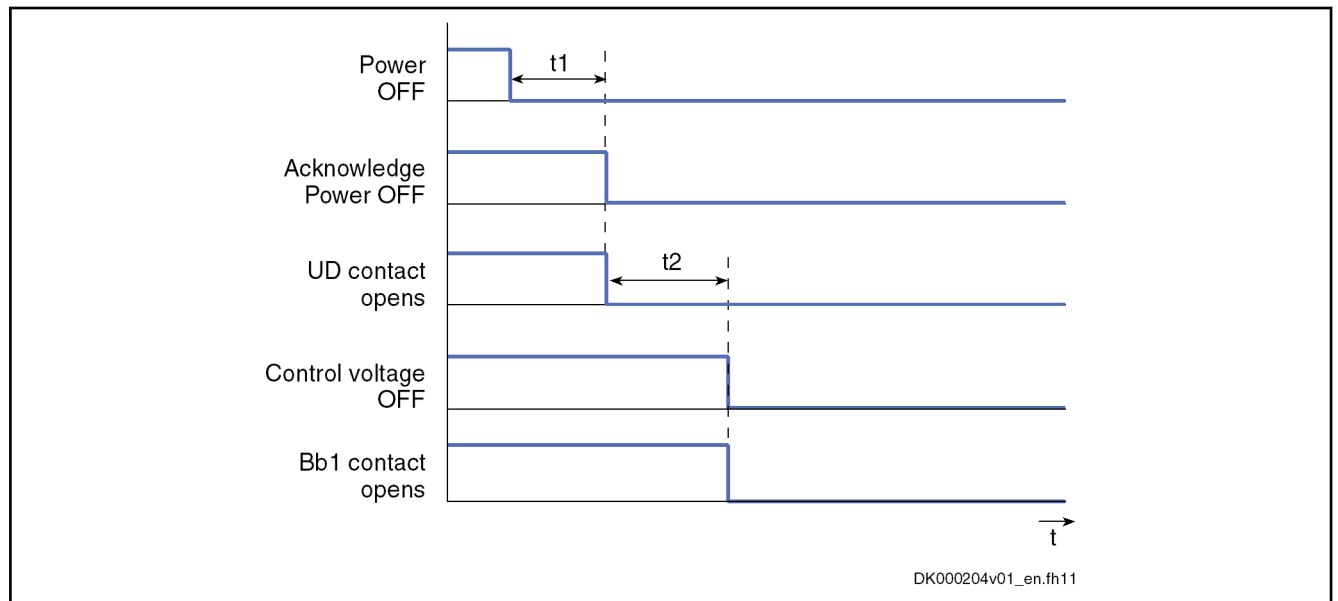

t1 Maximum 200 ms; depends on device (OFF delay of mains contactor)

t2 Time can be set by the user

Fig.9-18: Signal Sequences When Switching Off

NOTICE

Damage to the supply unit!

At **HMV01.1R** supply units, there must be **at least 10 ms** between the request mains OFF (signal at X32.6 / X32.7) and the disconnection of the mains voltage, so that the energy flow has been interrupted when the disconnection process starts.

You can make sure this order is observed by appropriate switch elements (e.g. by a main switch of the control cabinet with leading auxiliary contact). For this purpose, connect the auxiliary contact in series with mains OFF.

Involved Connection Points

See "Rexroth IndraDrive Supply Units and Power Sections" → chapter "Functions and Connection Points"

10 Electromagnetic Compatibility (EMC)

10.1 EMC Requirements

10.1.1 General Information

The electromagnetic compatibility (EMC) or electromagnetic interference (EMI) includes the following requirements:

- Sufficient **noise immunity** of an electric installation or an electric device against external electric, magnetic or electromagnetic interference via lines or through air
- Sufficiently low **noise emission** of electric, magnetic or electromagnetic noise of an electric installation or an electric device to other surrounding devices via lines or through air

10.1.2 Noise Immunity in the Drive System

Basic Structure for Noise Immunity

The figure below illustrates the interfaces for definition of noise immunity requirements in the drive system.

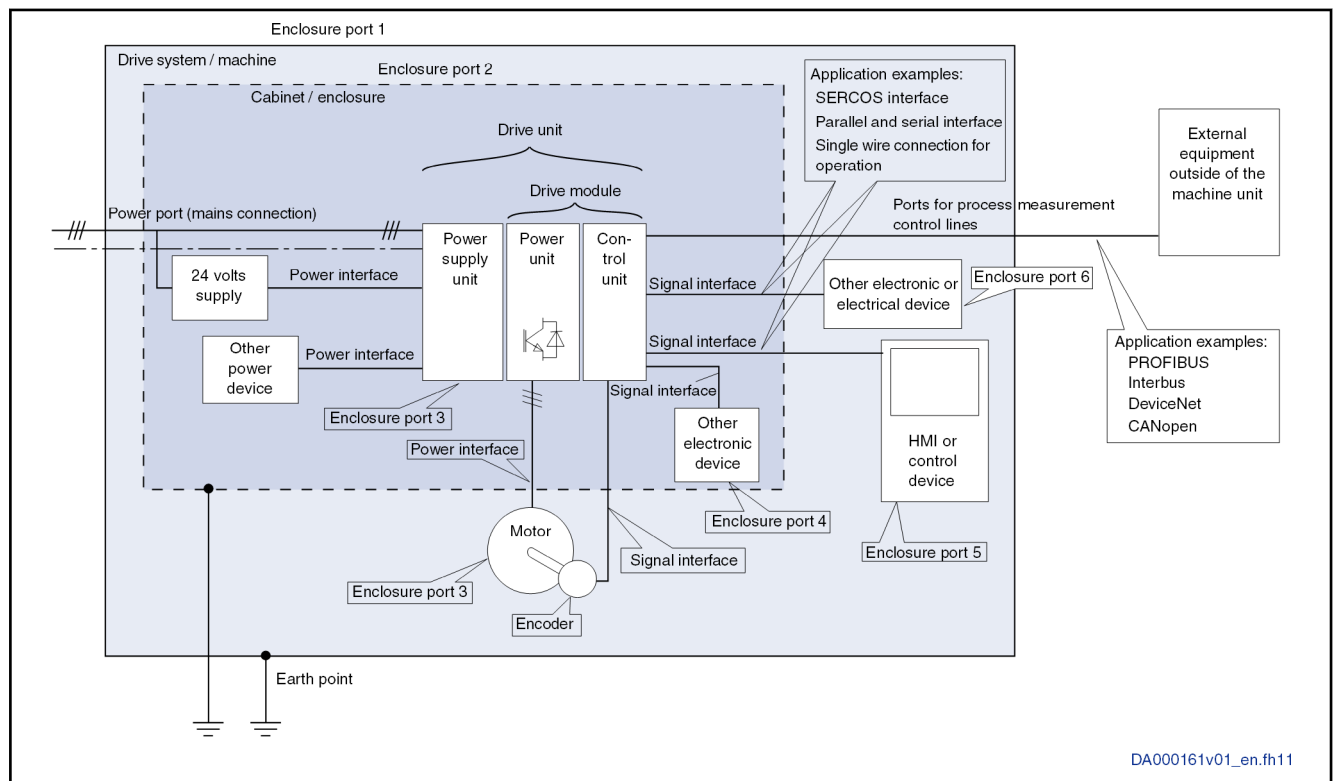

Fig. 10-1: Basic Structure and Noise Immunity

Electromagnetic Compatibility (EMC)

Limit Values for Noise Immunity

No	Place of effect	Phenomenon	Standard	Conditions	Coupling	Test values according standard EN 61800-3	Performance level
	Enclosure port		IEC 61000-4-2		CD, AD	6 kV CD, 8 kV AD, if CD not possible	B
		RF Field	IEC 61000-4-3		Via antenna on EUT	10 V / m	A
	Power port	Burst	IEC 61000-4-4	length > 3 m	mains connection I < 100 A: decoupling network I > 100 A: clamp	4 kV / 2.5 kHz (clamp)	B
		Surge	IEC 61000-4-5	Only mains connection; I < 63 A, light load test		Line – line 1 kV (2 Ohm) Line – earth 2 kV (12 Ohm)	B
			IEC 61000-4-6	length > 3 m	clamp	10 V, 0.15–80 MHz	A
	Power Interface	Burst	IEC 61000-4-4	length > 3 m	clamp		B
	Signal Interface	Burst	IEC 61000-4-4	length > 3 m	clamp		B
			IEC 61000-4-6	length > 3 m	Clamp or CDN	10 V, 0.15–80 MHz	B
	Ports of process; measurement control lines	Burst	IEC 61000-4-4	length > 3 m	clamp		B
			IEC 61000-4-6	length > 3 m	Clamp or CDN	10 V, 0.15–80 MHz	A

Tab. 10-1: Noise Immunity Limit Values

Evaluation Criterion	Explanation (abbreviated form from EN 61800-3)
A	Deviations within allowed range
B	Automatic recovery after interference
C	Switched off without automatic recovery. Device remains undamaged.

Tab. 10-2: Evaluation Criterion

10.1.3 Noise Emission of the Drive System

Causes of Noise Emission

Controlled variable-speed drives contain converters containing snappy semi-conductors. The advantage of modifying the speed with high precision is achieved by means of pulse width modulation of the converter voltage. This can generate sinusoidal currents with variable amplitude and frequency in the motor.

The steep voltage rise, the high clock rate and the resulting harmonics cause unwanted but physically unavoidable emission of interference voltage and interference fields (wide band interference). The interference mainly is asymmetric interference against ground.

The propagation of this interference strongly depends on:

Electromagnetic Compatibility (EMC)

- Configuration of the connected drives
- Number of the connected drives
- Conditions of mounting
- Site of installation
- Radiation conditions
- Wiring and installation

When the interference gets from the device to the connected lines in unfiltered form, these lines can radiate the interference into the air (antenna effect). This applies to power lines, too.

Limit Values for Line-Based Disturbances

According to IEC EN 61800-3 or CISPR 11 (corresponds to EN55011), the limit values in the table below are distinguished. For this documentation both standards are combined in the limit value classes A2.1 to B1.

IEC / EN 61800-3	CISPR 11 (EN55011)	Explanation	In this documentation	Curves of limit value characteristic
Category C4 2nd environment	None	One of the following 3 requirements must have been fulfilled: Mains connection current >400 A, IT mains or required dynamic drive behavior not reached by means of EMC filter. Adjust limit values to use and operation on site. User has to carry out and provide evidence of EMC planning.	None	-
Category C3 2nd environment	Class A; Group 2 I > 100 A	Limit value in industrial areas to be complied with for applications operated at supply mains with nominal currents > 100 A.	A2.1	1.1 1.2
Category C3 2nd environment	Class A; Group 2 I < 100 A	Limit value in industrial areas to be complied with for applications operated at supply mains with nominal currents < 100 A.	A2.2	2.1 2.2
Category C2 1st environment; Restricted distribution	Class A; Group 1	Limit value in residential area or at facilities at low-voltage mains supplying buildings in residential areas. To be complied with for applications with restricted distribution.	A1	3.1 3.2
Category C1 1st environment; Unrestricted distribution	Class B; Group 1	Limit value in residential areas to be complied with for applications with unrestricted distribution.	B1	4.1 4.2

Tab. 10-3: Limit Value Classes

Electromagnetic Compatibility (EMC)

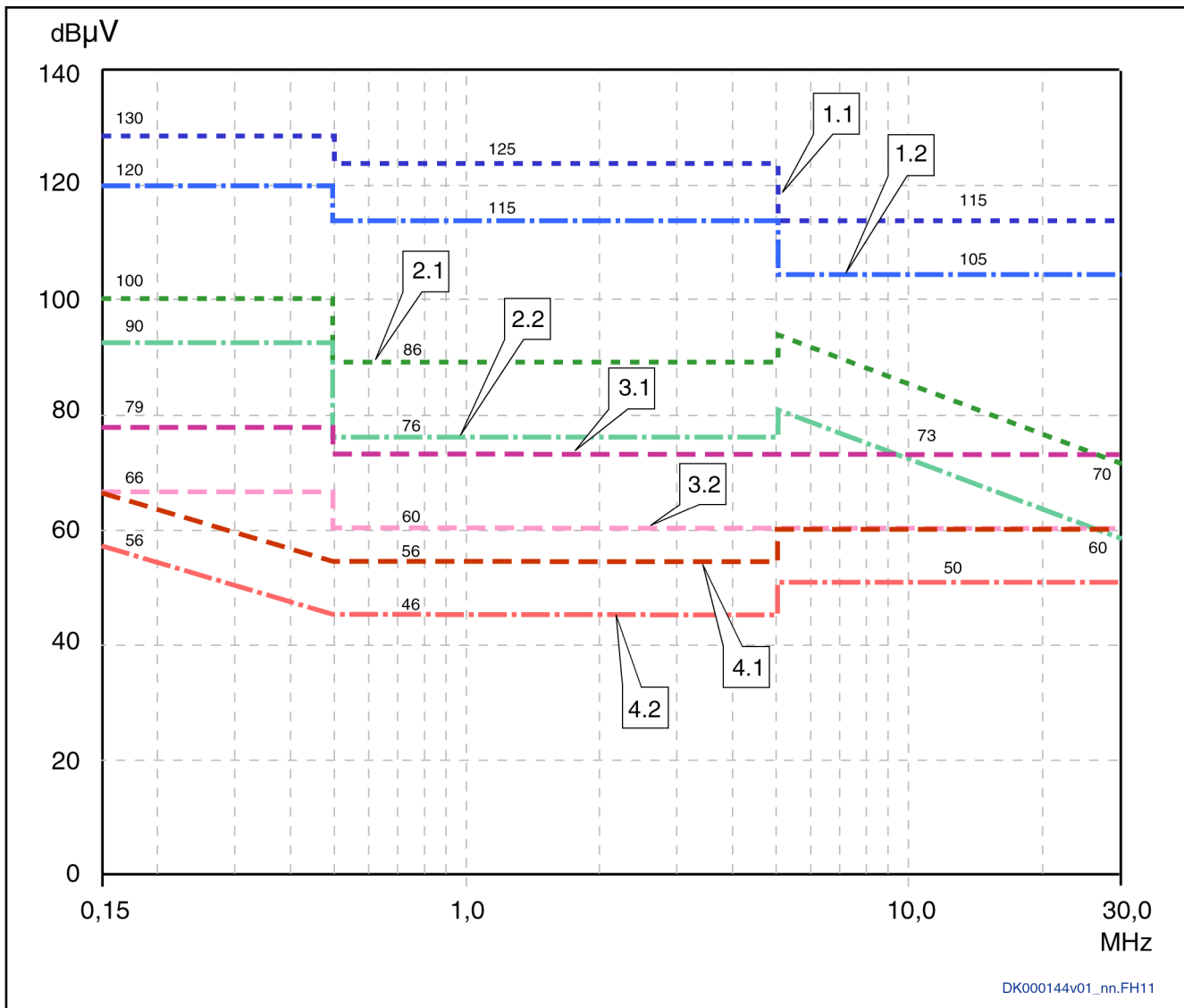

DK000144v01_nn.FH11

- 1.1 Category C3: Second environment, QSP, I > 100 A (class A, group 2, I > 100 A)
 - 1.2 Category C3: Second environment, AV, I > 100 A (class A, group 2, I > 100 A)
 - 2.1 Category C3: Second environment, QSP, I < 100 A (class A, group 2, I < 100 A)
 - 2.2 Category C3: Second environment, AV, I < 100 A (class A, group 2, I < 100 A)
 - 3.1 Category C2: First environment, restricted distribution, QSP (first environment, even if source of interference in second environment) (class A, group 1)
 - 3.2 Category C2: First environment, restricted distribution, AV (first environment, even if source of interference in second environment) (class A, group 1)
 - 4.1 Category C1: First environment, unrestricted distribution, QSP (first environment, even if source of interference in second environment) (class B, group 1)
 - 4.2 Category C1: First environment, unrestricted distribution, AV (first environment, even if source of interference in second environment) (class B, group 1)
- Notes (1) Limit value for first environment is also relevant, if source of interference of second environment affects first environment.
 (2) Designations "class" and "group" according to IEC CISPR 11.

Electromagnetic Compatibility (EMC)

QSP: Measuring method quasi peak measurement; AV: Measuring method arithmetic averaging

Fig. 10-2: *Limit Values for Line-Based Disturbances (IEC 61800-3); Limit Value Characteristic through Frequency Range*

Second Environment, Industrial Area

Facilities not directly connected to a low-voltage mains to supply buildings in residential areas.

If the limit values in an industrial area separated from public supply by a transformer station only have to be complied with at the property boundary or in the neighboring low-voltage mains, the filter might not be necessary. In the vicinity of broadcast receivers or other sensitive devices as regards high-frequency, such as measuring sensors, measuring lines or measuring devices, it is normally required to use the interference suppression filter.

Increasing the noise immunity of a sensitive device can often be the economically better solution compared to measures of interference suppression at the drive system of the installation.

First Environment

Environment containing residential areas and facilities directly connected, without interstage transformer, to a low-voltage mains supplying buildings in residential areas.

Medium-sized manufacturing plants and industrial establishments can be connected to the public low-voltage mains together with residential buildings. In this case, there is a high risk for radio and television reception if there aren't any measures for radio interference suppression taken. Therefore, the indicated measures are generally recommended.

Nominal Current of Supply Mains

The nominal current of the supply mains (> 100 A or < 100 A) is specified by the local power supply company at the connection point of the mains. For industrial companies, for example, such connection points are the interconnecting stations from the power supply system.

Unrestricted Distribution

Channel of distribution for which placing on the market is independent of the EMC expert knowledge of the customer or user of electric drives.

Restricted Distribution

Channel of distribution for which the placing on the market is restricted to traders, customers or users who individually or together have technical expert knowledge of EMC for the use of electric drives.

Since it is impossible to obtain the lower limit values for residential areas with all applications by means of the usual measures (like for example in the case of large and electrically not closed installations, longer motor cables or a large number of drives), the following note included in EN 61800-3 has to be observed.



Components of the drive system Rexroth IndraDrive are **products of category C3** (with restricted distribution) according to IEC 61800-3. They are not provided for use in a public low-voltage mains supplying residential areas. If they are used in such a mains, high-frequency interference is to be expected. This can require additional measures of radio interference suppression.

See the following chapters for the limit value classes (as per categories C1, C2, C3, C4 according to EN 61800-3) which can be reached for the individual drive systems and devices:

- [chapter "Mains Connection of HMV01.1E Supply Units" on page 110](#)
- [chapter "Mains Connection of HMV01.1R Supply Units" on page 111](#)
- [chapter "Mains Connection of HMV02.1R Supply Units" on page 112](#)
- [chapter "Mains Connection for HCS02 Converters" on page 114](#)
- [chapter "Mains Connection for HCS03 Converters" on page 116](#)

Electromagnetic Compatibility (EMC)

10.2 Ensuring the EMC Requirements

Standards and Laws On the European level there are the EU Directives. In the EU states these Directives are transformed into laws valid on a national level. The relevant directive for EMC is EU Directive 2004/108/EC which was transformed on the national level in Germany into the law EMVG ("Law concerning electromagnetic compatibility of devices") of 2008-02-26.

EMC Properties of Components Drive and control components by Rexroth are designed and built, in accordance with the present state-of-the-art of standardization, according to legal regulations of the EU Directive EMC 2004/108/EC and the German EMC law. The compliance with EMC standards was tested by means of a typical arrangement with a test setup conforming to standard with the indicated mains filters. The limit values according to product standard EN 61800-3 have been complied with.

Apart from the internal test at the factory, a conformity test was carried out for individual drive systems in an accredited laboratory of a CE-responsible authority.

Applicability for Finished Product Measurements of the drive system with an arrangement typical for the system are not in all cases applicable to the status as installed in a machine or installation. Noise immunity and noise emission strongly depend on:

- Configuration of the connected drives
- Number of the connected drives
- Conditions of mounting
- Site of installation
- Radiation conditions
- Wiring and installation

In addition, the required measures depend on the requirements of electric safety technology and economic efficiency in the application.

In order to prevent interference as far as possible, notes on mounting and installation are contained in the documentations of the components and in this documentation.



Observe the descriptions and notes in chapter [11 Arranging the Components in the Control Cabinet](#), page 189.

Cases to Distinguish for Declaration of EMC Conformity

For validity of the harmonized standards, we distinguish the following cases:

- **Case 1: Delivery** of the drive system.
According to the regulations, the product standard EN 61800-3 is complied with for Rexroth drive systems. The drive system is listed in the declaration of EMC conformity. This fulfills the legal requirements according to EMC directive.
- **Case 2: Acceptance test** of a machine or installation with the installed drive systems.

The product standard for the respective type of machine/installation, if existing, applies to the acceptance test of the machine or installation. In the last years, some new product standards were created for certain machine types and some are being created at present. These new product standards contain references to the product standard EN 61800-3 for drives or specify higher-level requirements demanding increased filter and installation efforts. When machine manufacturers want to put the machine/installation into circulation, the product standard relevant to

Electromagnetic Compatibility (EMC)

their machine/installation has to be complied with for their finished product "machine/installation". The authorities and test laboratories responsible for EMC normally refer to this product standard.

This documentation specifies the EMC properties which can be achieved, in a machine or installation, with a drive system consisting of the standard components.

It also specifies the conditions under which the indicated EMC properties can be achieved.

10.3 Measures to Reduce Noise Emission

10.3.1 General Information

To reduce noise emission, there are mainly three possible measures:

- Filtering by means of mains filter
- Shielding by mounting and shielded cables
- Grounding by electrical bonding

Noise Emission of the Drive Systems

In order to comply with the limit values for noise emission (mainly line-based radio interference of more than 9 kHz) at the connection points of the machine or installation, observe the notes on application contained in this documentation.

10.3.2 Shielding

Sufficient metallic shielding prevents radiation into the air. This is achieved by mounting the devices in a grounded control cabinet or in a housing (metallic encapsulation). The shielding of line connections is realized by shielded cables and lines, the shield has to be grounded over a large surface area.

To connect the shield at the motor, a suitable PG gland with shield connection can be used. Make sure that the connection between the motor terminal box and the motor housing has a low impedance (if necessary, use an additional grounding strap). Never use plastic motor terminal boxes!

10.3.3 Grounding

Grounding discharges interference to ground and makes it flow back to the source of interference over the shortest distance. Realize grounding via a sufficiently **short connection over the largest possible surface area** in order to achieve low inductive resistance with a low degree of line inductance. The higher the frequency of disturbances, the lower the line inductance of grounding has to be.



In ungrounded mains, the measure "grounding" cannot be generally used.

10.3.4 Filtering

Filtering prevents emission of noise via the lines, especially via the mains connection. For this purpose, there are special interference suppression filters available with which

- the allowed limit values of the line-based interference emission can be complied with in the range of 50 kHz to 30 MHz.
- interference via the mains connection to devices connected near by (e.g., control unit components) can be reduced.

11 Arranging the Components in the Control Cabinet

11.1 Dimensions and Distances

11.1.1 Main Dimensions of the System Components

General Information



The **mounting depths** of the Rexroth IndraDrive product range have been optimized for mounting in control cabinets:

- Mounting depths up to **265 mm**: For control cabinets with a depth of 300 mm
- Mounting depths up to **322 mm**: For control cabinets with a depth of 400 mm

The figure below contains a rough overview of the main dimensions.

For other data and required mounting dimensions, see Project Planning Manual "Rexroth IndraDrive Supply Units and Power Sections" → Chapter of the respective device → "Technical Data" → "Mechanical System and Mounting"

Device Depths and Device Heights

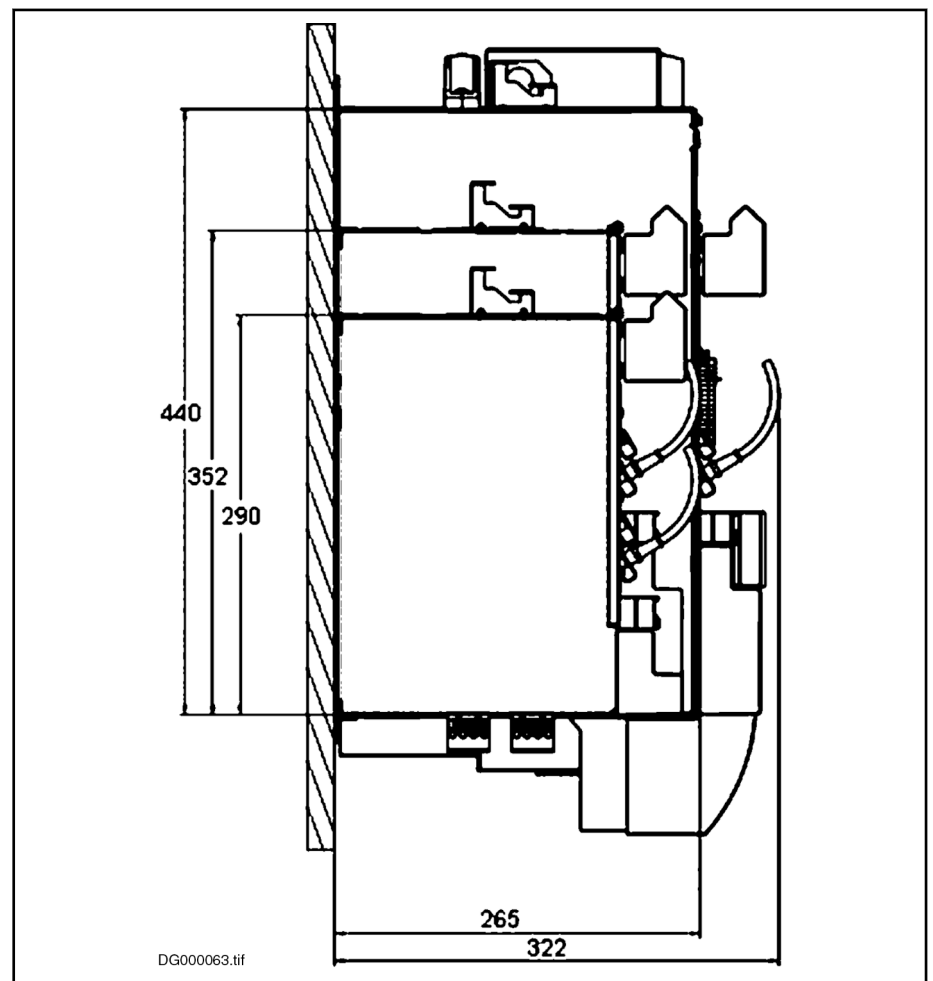

Fig.11-1: Main Dimensions in mm

Arranging the Components in the Control Cabinet

11.1.2 Distances

General Information

In addition to the mounting dimensions, the devices of the Rexroth IndraDrive range require additional mounting clearance:

- To ventilate the devices
- To mount accessories and connections
- To take temperature limits of neighboring mounting parts, such as cable ducts etc., into account

For the required mounting clearance in the control cabinet, take additional distances between the devices and on their tops and bottoms into account.

 For the distances to be complied with, d_{top} (distance to top of device), d_{bot} (distance to bottom of device) and d_{hor} (distance to side of device), see Project Planning Manual "Rexroth IndraDrive Supply Units and Power Sections" → Chapter of the respective device → "Technical Data" → "Mechanical System and Mounting" → "Power Dissipation, Mounting Position, Cooling, Distances"

Distance Between the Devices

Owing to power dissipation in the devices, especially due to integrated braking resistors, the temperatures of neighboring devices are rising. In the case of lateral mounting, trouble-free operation therefore requires the following minimum distances (in mm) between the devices.

Minimum distance [mm]						
Between	and					
	HCS02	HCS03 (HNK01, HLR01)	HMV01	HMV02	HMS01 / HMD01	HMS02
HCS02.1E	5	--	--	--	0 (HMS to the right of HCS) 5 (HMS to the left of HCS)	0 (HMS to the right of HCS) 5 (HMS to the left of HCS)
HCS03.1E with HNK01 and HLR01	--	0	--	--	0	--
HMV01.1E / HMV01.1R	--	--	0	--	0	--
HMS01.1 / HMD01.1	0 (HMS to the right of HCS) 5 (HMS to the left of HCS)	0	0	--	0	--
HMV02.1R	--	--	--	--	--	0
HMS02.1	0 (HMS to the right of HCS) 5 (HMS to the left of HCS)	0	0	0	0	0

-- Not allowed

Tab. 11-1: Minimum Distances

Arranging the Components in the Control Cabinet



For arrangement of the devices in the control cabinet, take the required minimum distances into account besides the device dimensions.

Distance to the Bottom of the Devices

In order that there is sufficient cooling air available for cooling the devices, a minimum distance to other devices must be complied with from the bottom of the devices. This applies both to the intake space of devices with forced cooling and to devices with cooling by natural convection.

In the thermal steady-state condition of the drive system, the temperature at the **air intake** of the device is the ambient temperature of the device. The temperature at the air intake is relevant when you check whether the allowed ambient temperature range T_{a_work} (see technical data of the respective device) has been complied with.



Keep the space at the air intake free from unnecessary barriers.

Run the cables as short as possible and without loops.

Do not place loads with power dissipation (e.g. mains chokes, braking resistors) near the air intake.

Use barrier plates, if necessary.

Form a **channel** which is as obstacle-free as possible and corresponds at least to the cross section " $d_{bot} \times$ mounting depth". The channel should lead with at least this cross section to the air intakes at the bottom and at the top of the devices.



If there are different minimum distances for the individual devices in a drive system, the greatest value determines the minimum distance to be observed for the entire row in the drive system.

Distance to the Top of the Devices

In order that the cooling systems can transport the cooling air through the devices and heat does not accumulate, a minimum distance to the top of the devices must be complied with.



Keep the space at the air outlet free from unnecessary barriers.

Where possible, run the cables and lines outside the outlet apertures.

The supplied cooling air is heated up due to the power dissipation generated in the devices.

In a distance of d_{top} above the devices, the temperature of the cooling air is up to 105 °C.

Directly at the outlet holes – especially of devices with integrated braking resistor and DC bus short circuit device – the temperature of the cooling air can be significantly higher than 105 °C.

Arranging the Components in the Control Cabinet

NOTICE

Risk of fire caused by the "sacrificing behavior" of the ZKS stage!

The "ZKS" input activates the "DC bus short circuit" function, when the 24V control voltage has not been applied and when there isn't any current flowing to the input. This condition can occur in the following situations:

- Failure of 24V control voltage
- Wire break
- Activation of serially connected contacts (e.g. axis limit switches)

If the kinetic energy of the mechanical axis system regenerated when braking is greater than the energy absorption capacity of HLB, the HLB device remains active when braking via ZKS takes place, until it is thermally destroyed (sacrificing behavior). Risk of fire! In this case, braking via ZKS may only come into effect in the case of an emergency (e.g. activation of an axis limit switch causes the mains supply to be cut off and simultaneously causes the 24V supply of the ZKS input to be interrupted).

Install a 24V UPS, if the "sacrificing behavior" of HLB is relevant to your drive system in the case of an emergency. This prevents the braking via ZKS which causes HLB to be destroyed due to the failure of the 24V control voltage. Braking via ZKS then will only take place in cases of emergency.

NOTICE

Property damage due to temperatures higher than 105 °C!

Observe the indicated minimum distances!

Above the devices there may only be such materials which

- are not combustible
- are insensitive to the occurring high temperatures

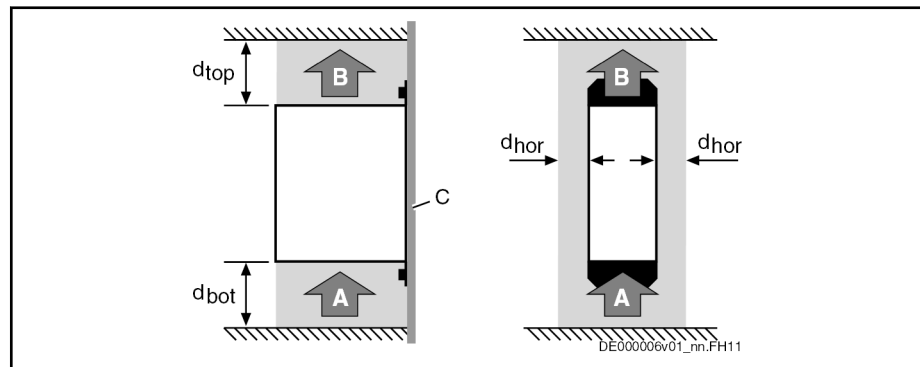

A	Air intake
B	Air outlet
C	Mounting surface in control cabinet
d_{top}	Distance top
d_{bot}	Distance bottom
d_{hor}	Distance horizontal

Fig. 11-2: Air Intake and Air Outlet at Device

Arranging the Components in the Control Cabinet



If there are different minimum distances for the individual devices in a drive system, the greatest value determines the minimum distance to be observed for the entire row in the drive system.

For example, if a supply unit with integrated braking resistor is used and operated with nominal power, its minimum distance d_{top} of for example 300 mm determines the minimum distance for the connected HMS / HMD drive controllers, see figure "Minimum Distance at HMV Supply Units".

Minimum Distance of HMV Supply Units

The braking resistor in HMV01.1E heats up during operation, the braking resistor in HMV01.1R and HMV02.1R does so particularly after power has been switched off.

Under rated load, the escaping cooling air has cooled down in the minimum distance to below 105 °C. If the integrated braking resistor is not loaded, the distance can be reduced to 80 mm.

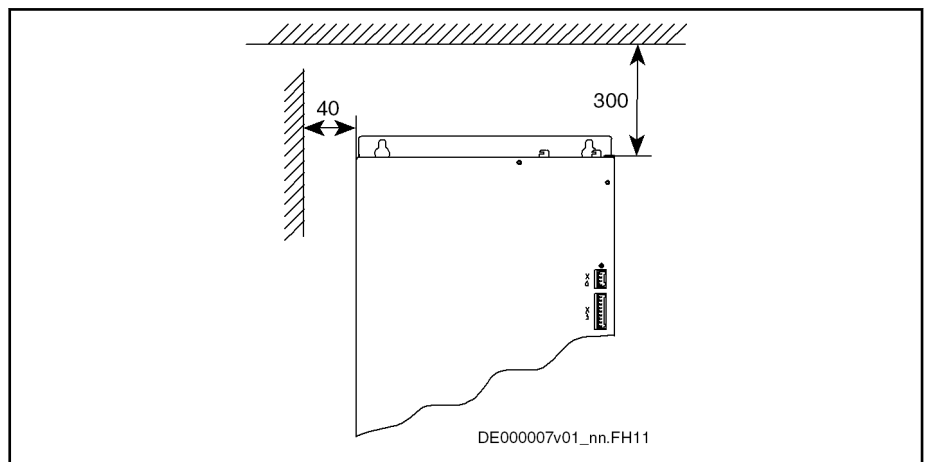

Fig. 11-3: Minimum Distance at HMV Supply Units

Lateral Distance at Drive System

In order that the cooling air can circulate in the closed control cabinet, a distance at the sides of the drive system is required in addition to the distances at the top and at the bottom.

In the closed control cabinet, the circulation is provoked by the natural convection and supported by the device-internal fans.

Arranging the Components in the Control Cabinet

11.1.3 Boring Dimensions for the Mounting Plate

Individually Arranged Devices

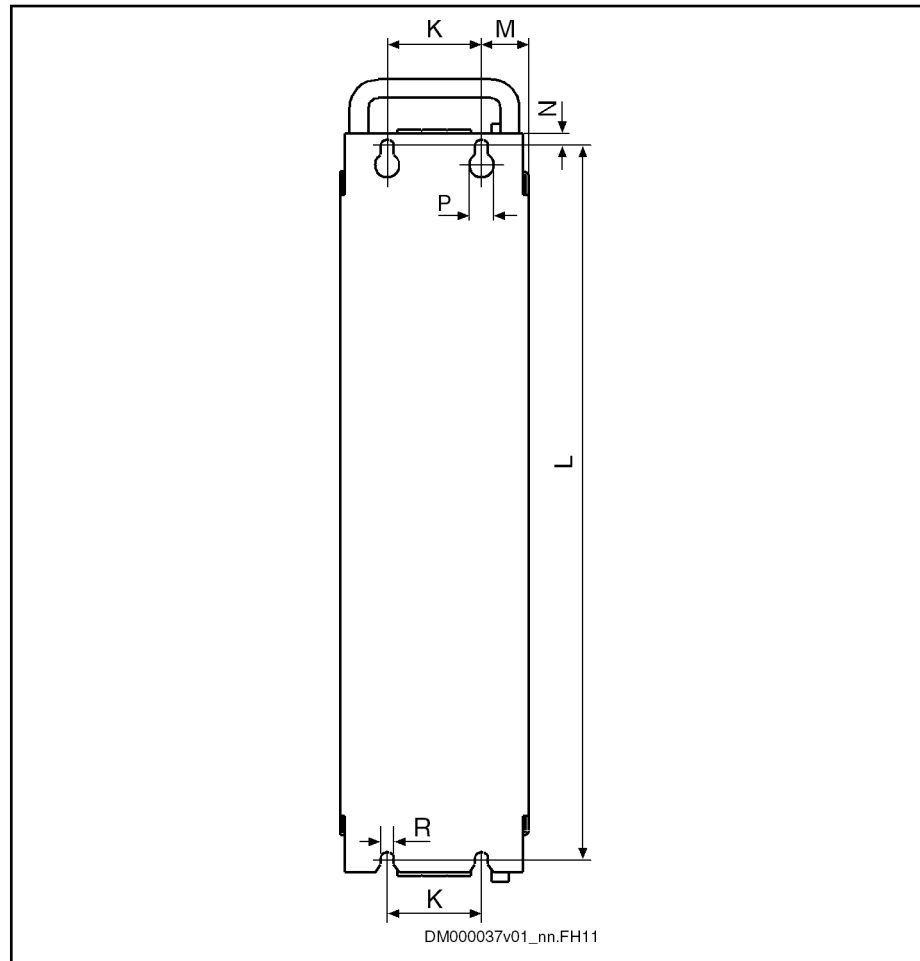

Fig.11-4: Boring dimensions



The figure shows the back of a device.

Device	K [mm]	L [mm]	M [mm]	P [mm]	R [mm]	Notes
HCS02.1E-W0012	0	316	32,5	13	7	Observe additional distance to lateral neighboring devices
HCS02.1E-W0028	0	378	32,5	13	7	Observe additional distance to lateral neighboring devices
HCS02.1E-W0054	55	378	25	13	7	Observe additional distance to lateral neighboring devices
HCS02.1E-W0070	55	378	25	13	7	Observe additional distance to lateral neighboring devices
HCS03.1E-W0070	75	466	25	13	7	
HCS03.1E-W0100	175	466	25	13	7	
HCS03.1E-W0150	175	466	25	13	7	

Arranging the Components in the Control Cabinet

Device	K [mm]	L [mm]	M [mm]	P [mm]	R [mm]	Notes
HCS03.1E-W0210	250	466	50	13	7	
HMV01.1E-W0030	100	466	25	13	7	
HMV01.1E-W0075	200	466	25	13	7	
HMV01.1E-W0120	300	466	25	13	7	
HMV01.1R-W0018	125	466	25	13	7	
HMV01.1R-W0045	200	466	25	13	7	
HMV01.1R-W0065	300	466	25	13	7	
HMV01.1R-W0120	300	466	25	13	7	
HMV02.1R-W0015	100	378	25	13	7	
HMS01.1N-W0020	0	466	25	13	7	
HMS01.1N-W0036	0	466	25	13	7	
HMS01.1N-W0054	0	466	25	13	7	
HMS01.1N-W0070	50	466	25	13	7	
HMS01.1N-W0150	100	466	25	13	7	
HMS01.1N-W0210	150	466	25	13	7	
HMS01.1N-W0350	300	466	25	13	7	
HMS02.1N-W0028	0	378	25	13	7	
HMS02.1N-W0054	0	378	25	13	7	
HMD01.1N-W0012	0	466	25	13	7	
HMD01.1N-W0020	0	466	25	13	7	
HMD01.1N-W0036	0	466	25	13	7	
HNL02.1	100	378	20	13	7	
HNS02.1	0	378	55	13	7	
HLB01.1C	0	378	32,5	13	7	
HLB01.1D	50	466	25	13	7	
HLC01.1C-01M0	0	378	25	13	7	
HLC01.1C-02M4	0	378	25	13	7	
HLC01.1D-05M0	0	466	25	13	7	

Tab. 11-2: Boring dimensions

Ground the housings of the devices!

1. Connect the bare metal back panel of the device in conductive form to the mounting surface in the control cabinet.
2. Use the supplied mounting screws and fix the screws with a tightening torque of typically 6 Nm.
3. Connect the mounting surface of the control cabinet in conductive form to the equipment grounding system.

Arranging the Components in the Control Cabinet

Combination of Devices of the Rexroth IndraDrive M Product Range

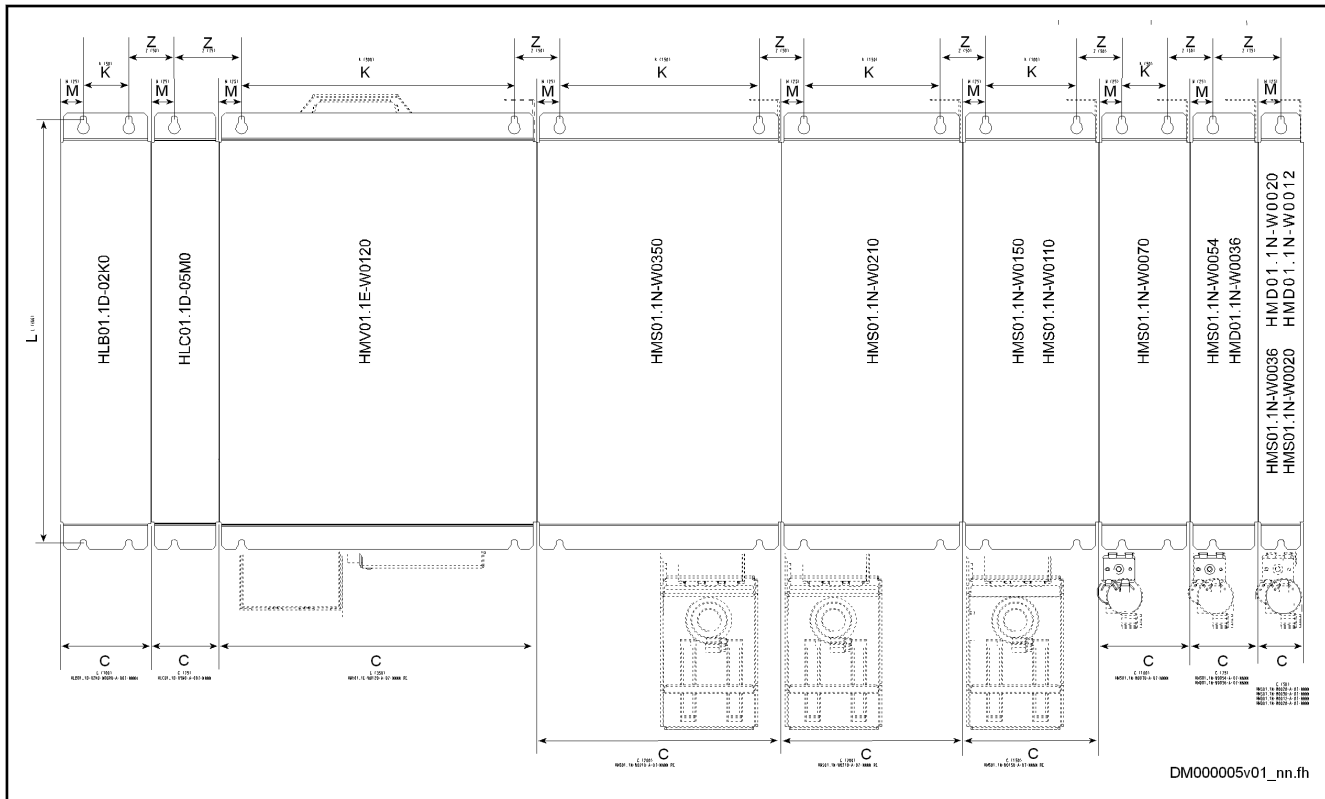

Fig. 11-5: Rexroth IndraDrive M Devices



The prevailing grid of mounting holes within the Rexroth IndraDrive M product range is **25 mm**.

Arrange the drive controllers with high capacity as close to the supplying device as possible.

The **HAS02** accessories in the figure require additional downward mounting clearance.

Dimension Z is significantly determined by the involved devices. The table below contains the dimensions Z between the device arranged to the left and the device arranged to the right.

Arranging the Components in the Control Cabinet

Device to the left	Device to the right	Dimension Z [mm]
HMV01.1E-W0030 HMV01.1E-W0075 HMV01.1E-W0120 HMV01.1R-W0018 HMV01.1R-W0045 HMV01.1R-W0065 HMV01.1R-W0120 HMS01.1N-W0020 HMS01.1N-W0036 HMS01.1N-W0070 HMS01.1N-W0110 HMS01.1N-W0150 HMS01.1N-W0210 HMS01.1N-W0350 HMD01.1N-W0012 HMD01.1N-W0020	HMS01.1N-W0020 HMS01.1N-W0036 HMS01.1N-W0054 HMS01.1N-W0070 HMS01.1N-W0110 HMS01.1N-W0150 HMS01.1N-W0210 HMS01.1N-W0350 HMD01.1N-W0012 HMD01.1N-W0020 HMD01.1N-W0036 HLC01.1D-05M0 HLB01.1D	50
HMV01.1E-W0030 HMV01.1E-W0075 HMV01.1E-W0120 HMV01.1R-W0018 HMV01.1R-W0045 HMV01.1R-W0065 HMV01.1R-W0120 HMS01.1N-W0020 HMS01.1N-W0036 HMS01.1N-W0070 HMS01.1N-W0110 HMS01.1N-W0150 HMS01.1N-W0210 HMS01.1N-W0350 HMD01.1N-W0012 HMD01.1N-W0020	HLB01.1C	57,5

Arranging the Components in the Control Cabinet

Device to the left	Device to the right	Dimension Z [mm]
HMS01.1N-W0054 HMD01.1N-W0036 HLC01.1D-05M0	HMV01.1E-W0030 HMV01.1E-W0075 HMV01.1E-W0120 HMV01.1R-W0018 HMV01.1R-W0045 HMV01.1R-W0065 HMS01.1N-W0020 HMS01.1N-W0036 HMS01.1N-W0070 HMS01.1N-W0110 HMS01.1N-W0150 HMS01.1N-W0210 HMS01.1N-W0350 HMD01.1N-W0012 HMD01.1N-W0020 HLC01.1D-05M0 HLB01.1D	75
HLC01.1C-01M0 HLC01.1C-02M4	HMV01.1E-W0030 HMV01.1E-W0075 HMV01.1E-W0120 HMV01.1R-W0018 HMV01.1R-W0045 HMV01.1R-W0065 HMV01.1R-W0120 HMS01.1N-W0020 HMS01.1N-W0036 HMS01.1N-W0070 HMS01.1N-W0110 HMS01.1N-W0150 HMS01.1N-W0210 HMS01.1N-W0350 HMD01.1N-W0012 HMD01.1N-W0020 HLC01.1D-05M0 HLB01.1D	57,5
HLC01.1C-01M0 HLC01.1C-02M4	HLC01.1C-01M0 HLC01.1C-02M4	65

Tab. 11-3: Table for Dimension Z

Arranging the Components in the Control Cabinet

Combination of Drive Controllers of the Rexroth IndraDrive C Product Range

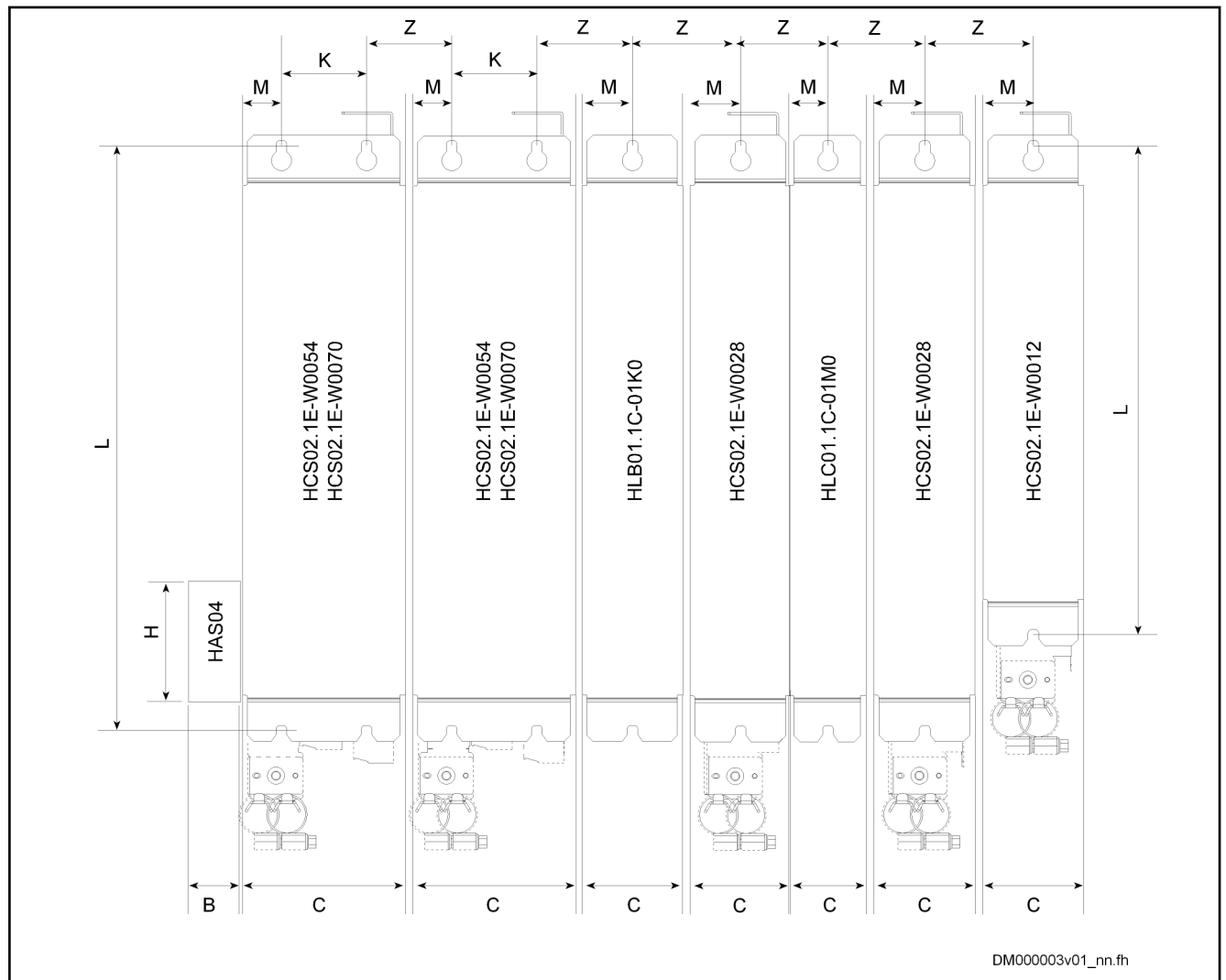

Fig.11-6: Rexroth IndraDrive C Devices



The accessory **HAS04** requires additional mounting clearance at the HCS arranged at the utmost left position.

Rexroth IndraDrive devices are arranged in line **to the right** starting from the supplying device. Arrange the drive controllers with high capacity as close to the supplying device as possible.

The **HAS02** accessories in the figure require additional downward mounting clearance.

Dimension Z is significantly determined by the involved devices. The table below contains the dimensions Z between the device arranged to the left and the device arranged to the right.

Arranging the Components in the Control Cabinet

Device to the left	Device to the right	Dimension Z [mm]
HCS02.1E-W0012 HCS02.1E-W0028 HLB01.1C	HCS02.1E-W0012 HCS02.1E-W0028 HLB01.1C	70
HCS02.1E-W0054 HCS02.1E-W0070	HCS02.1E-W0054 HCS02.1E-W0070	55
HLC01.1C-01M0 HLC01.1C-02M4 HCS02.1E-W0054 HCS02.1E-W0070	HLC01.1C-01M0 HLC01.1C-02M4	50 (without a distance between the devi- ces)
HCS02.1E-W0012 HCS02.1E-W0028 HLB01.1C	HLC01.1C-01M0 HLC01.1C-02M4	57,5 (without a distance between the devi- ces)
HCS02.1E-W0054 HCS02.1E-W0070 HLC01.1C-01M0 HLC01.1C-02M4	HCS02.1E-W0012 HCS02.1E-W0028 HLB01.1C	62,5
HCS03.1E-W0070 HCS03.1E-W0100 HCS03.1E-W0150	HCS03.1E-W0070 HCS03.1E-W0100 HCS03.1E-W0150	50 (without a distance between the devi- ces)
HCS03.1E-W0210	HCS03.1E-W0210	100 (without a distance between the devi- ces)
HCS03.1E-W0070 HCS03.1E-W0100 HCS03.1E-W0150	HCS03.1E-W0210	75 (without a distance between the devi- ces)
HCS03.1E-W0210	HCS03.1E-W0070 HCS03.1E-W0100 HCS03.1E-W0150	75 (without a distance between the devi- ces)

Tab. 11-4: Table for Dimension Z

Combination of Drive Controllers of the Rexroth IndraDrive C and M Product Ranges



The accessory **HAS04** requires additional mounting clearance at the HCS arranged at the utmost left position.

Rexroth IndraDrive M devices are arranged in line **to the right** starting from the supplying drive controller HCS.

Arranging the Components in the Control Cabinet

Dimension Z is significantly determined by the involved devices. The table below contains the dimensions Z between the device arranged to the left and the device arranged to the right.

HCS02 Drive Controllers

Device to the left	Device to the right	Dimension Z [mm]
HCS02.1E-W0054 HCS02.1E-W0070	HMS01.1N-W0020 HMS01.1N-W0036 HMS01.1N-W0054 HMS02.1N-W0028 HMS02.1N-W0054 HMD01.1N-W0012 HMD01.1N-W0020 HMD01.1N-W0036 HLC01.1D-05M0 HLB01.1D	50 (without a distance between the devices)

Tab. 11-5: Table for Dimension Z

HCS03 Drive Controllers

Device to the left	Device to the right	Dimension Z [mm]
HCS03.1E-W0070 HCS03.1E-W0100 HCS03.1E-W0150	HMS01.1N-W0020 HMS01.1N-W0036 HMS01.1N-W0054 HMS01.1N-W0070 HMD01.1N-W0012 HMD01.1N-W0020 HMD01.1N-W0036	50 (without a distance between the devices)
HCS03.1E-W0210	HMS01.1N-W0020 HMS01.1N-W0036 HMS01.1N-W0054 HMS01.1N-W0070 HMS01.1N-W0110 HMS01.1N-W0150 HMD01.1N-W0012 HMD01.1N-W0020 HMD01.1N-W0036	75 (without a distance between the devices)

Tab. 11-6: Table for Dimension Z



For the dimensions Z between other combinations see previous tables.

11.2 Arranging Components From Electrical Point of View

11.2.1 General Information

The section below contains information and recommendations on the arrangement of the devices in the control cabinet from mainly electrical points

Arranging the Components in the Control Cabinet

of view. These points of view include aspects of performance-dependent arrangement and electromagnetically compatible installation.

11.2.2 Performance-Dependent Arrangement

Arrangement With HMV

The **HMV01** supply units can supply HMS and HMD drive controllers **on both sides**.



When you use HNS02 and HNL02, the supply units **HMV02** only allow mounting them on one side to the **right**.

- Arrange drive controllers according to their performance. Arrange drive controllers with high performance as close to the supply unit as possible. Ideally, the drive controllers should be distributed equally to the left and right side of the supply unit.
- Arrange DC bus capacitor unit (HLC) next to the supply unit.
- Arrange DC bus resistor unit (HLB) next to the supply unit.
- When simultaneously using DC bus resistor unit and DC bus capacitor unit in a drive system, arrange the DC bus capacitor unit between supply unit and DC bus resistor unit.

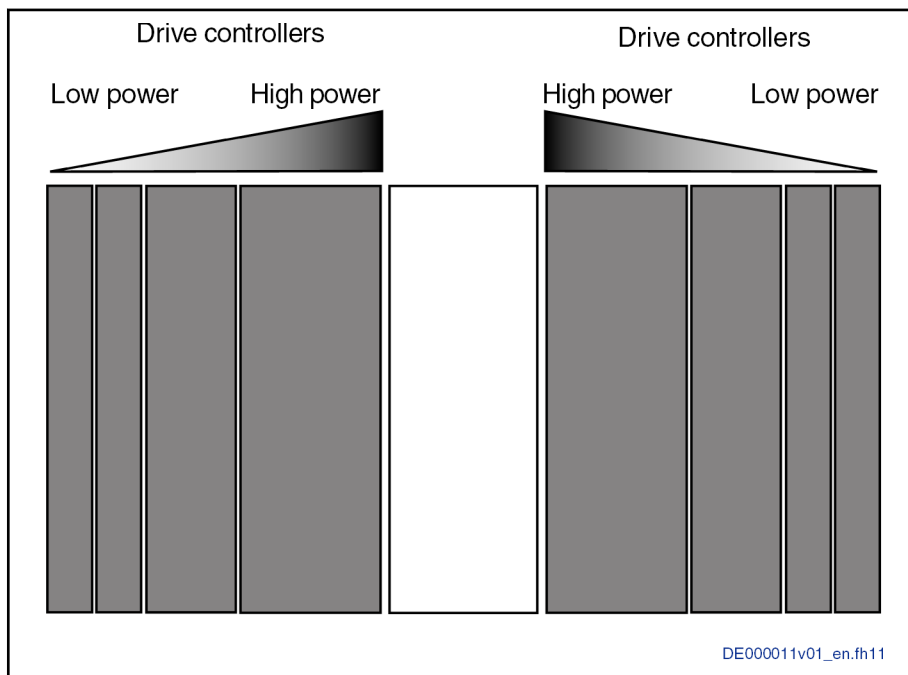

Fig. 11-7: Example of Arrangement

Arrangement With HCS

When you operate **HCS** converters in the type of mains connection "central supply", place the supplied drive controllers to the **right** of the HCS converters.

- Arrange DC bus capacitor unit next to drive controller with the greatest DC bus continuous power.
- Arrange DC bus resistor unit next to drive controller with the greatest regenerative power.
- When simultaneously using DC bus resistor unit and DC bus capacitor unit in a drive system, arrange the DC bus capacitor unit to the right of HCS and the DC bus resistor unit to the right of the DC bus capacitor unit.

Arranging the Components in the Control Cabinet

- Arrange HLR braking resistors in "standard" design above the HCS03 drive controller.

11.2.3 EMC Measures for Design and Installation

Rules for Design of Installations With Drive Controllers in Compliance With EMC

The following rules are the basics for designing and installing drives in compliance with EMC.

Mains filter	Correctly use a mains filter recommended by Rexroth for radio interference suppression in the supply feeder of the drive system.
Control Cabinet Grounding	Connect all metal parts of the cabinet with one another over the largest possible surface area to establish a good electrical connection. This, too, applies to the mounting of the mains filter. If required, use serrated washers which cut through the paint surface. Connect the cabinet door to the control cabinet using the shortest possible grounding straps.
Line Routing	<p>Avoid coupling routes between lines with high potential of noise and noise-free lines; therefore, signal, mains and motor lines and power cables have to be routed separately from another. Minimum distance: 10 cm. Provide separating sheets between power and signal lines. Ground separating sheets several times.</p> <p>The lines with high potential of noise include:</p> <ul style="list-style-type: none"> • Lines at the mains connection (incl. synchronization connection) • Lines at the motor connection • Lines at the DC bus connection <p>Generally, interference injections are reduced by routing cables close to grounded sheet steel plates. For this reason, cables and wires should not be routed freely in the cabinet, but close to the cabinet housing or mounting panels. Separate the incoming and outgoing cables of the radio interference suppression filter.</p>
Interference Suppression Elements	<p>Provide the following components in the control cabinet with interference suppression combinations:</p> <ul style="list-style-type: none"> • Contactors • Relays • Solenoid valves • Electromechanical operating hours counters <p>Connect these combinations directly at each coil.</p>
Twisted Wires	Twist unshielded wires belonging to the same circuit (feeder and return cable) or keep the surface between feeder and return cable as small as possible. Wires that are not used have to be grounded at both ends.
Lines of Measuring Systems	Lines of measuring systems must be shielded. Connect the shield to ground at both ends and over the largest possible surface area. The shield may not be interrupted, e.g. using intermediate terminals.
Digital Signal Lines	Ground the shields of digital signal lines at both ends (transmitter and receiver) over the largest possible surface area and with low impedance. In the case of bad ground connection between transmitter and receiver, additionally route a bonding conductor (min. 10 mm ²). Braided shields are better than foil shields.
Analog Signal Lines	Ground the shields of analog signal lines at one end (transmitter or receiver) over the largest possible surface area and with low impedance. This avoids low-frequency interference current (in the mains frequency range) on the shield.

Arranging the Components in the Control Cabinet

- | | |
|---|--|
| Connecting the Mains Choke | Keep connection lines of the mains choke at the drive controller as short as possible and twist them. |
| Installing the Motor Power Cable | <ul style="list-style-type: none"> • Use shielded motor power cables or run motor power cables in a shielded duct • Use the shortest possible motor power cables • Ground shield of motor power cable at both ends over the largest possible surface area to establish a good electrical connection • Run motor lines in shielded form inside the control cabinet • Do not use any steel-shielded lines • The shield of the motor power cable mustn't be interrupted by mounted components, such as output chokes, sine filters or motor filters |

EMC-Optimal Installation in Facility and Control Cabinet

General Information

For EMC-optimal installation, a spatial separation of the interference-free area (mains connection) and the interference-susceptible area (drive components) is recommended, as shown in the figures below.



Recommendation: For EMC-optimal installation in the control cabinet, use a separate control cabinet panel for the drive components.

Division Into Areas (Zones)

Exemplary arrangements in the control cabinet: See section [Control Cabinet Design According to Interference Areas - Exemplary Arrangements, page 205](#).

We distinguish three areas:

1. Interference-free area of control cabinet (**area A**):

This includes:

- Supply feeder, input terminals, fuse, main switch, mains side of mains filter for drives and corresponding connecting lines
- Control voltage or auxiliary voltage connection with power supply unit, fuse and other parts unless connection is run via the mains filter of the AC drives
- All components that are not electrically connected with the drive system

2. Interference-susceptible area (**area B**):

- Mains connections between drive system and mains filter for drives, mains contactor
- Interface lines of drive controller

3. Strongly interference-susceptible area (**area C**):

- Motor power cables including single cores

Never run lines of one of these areas in parallel with lines of another area so that there isn't any unwanted interference injection from one area to the other and that the filter is jumpered with regard to high frequency. Use the shortest possible connecting lines.

Recommendation for complex systems: Install drive components in one cabinet and the control units in a second, separate cabinet.

Arranging the Components in the Control Cabinet

Badly grounded control cabinet doors act as antennas. Therefore, connect the control cabinet doors to the cabinet on top, in the middle and on the bottom via short equipment grounding conductors with a cross section of at least 6 mm² or, even better, via grounding straps with the same cross section. Make sure connection points have good contact.

Control Cabinet Design According to Interference Areas - Exemplary Arrangements

**Do not operate any additional loads at the mains filter!**

Do not operate any other loads at the connection from the mains filter output to the mains connection of the supply unit.

For motor fans and power supply units, for example, use separate mains filters.

Arranging the Components in the Control Cabinet

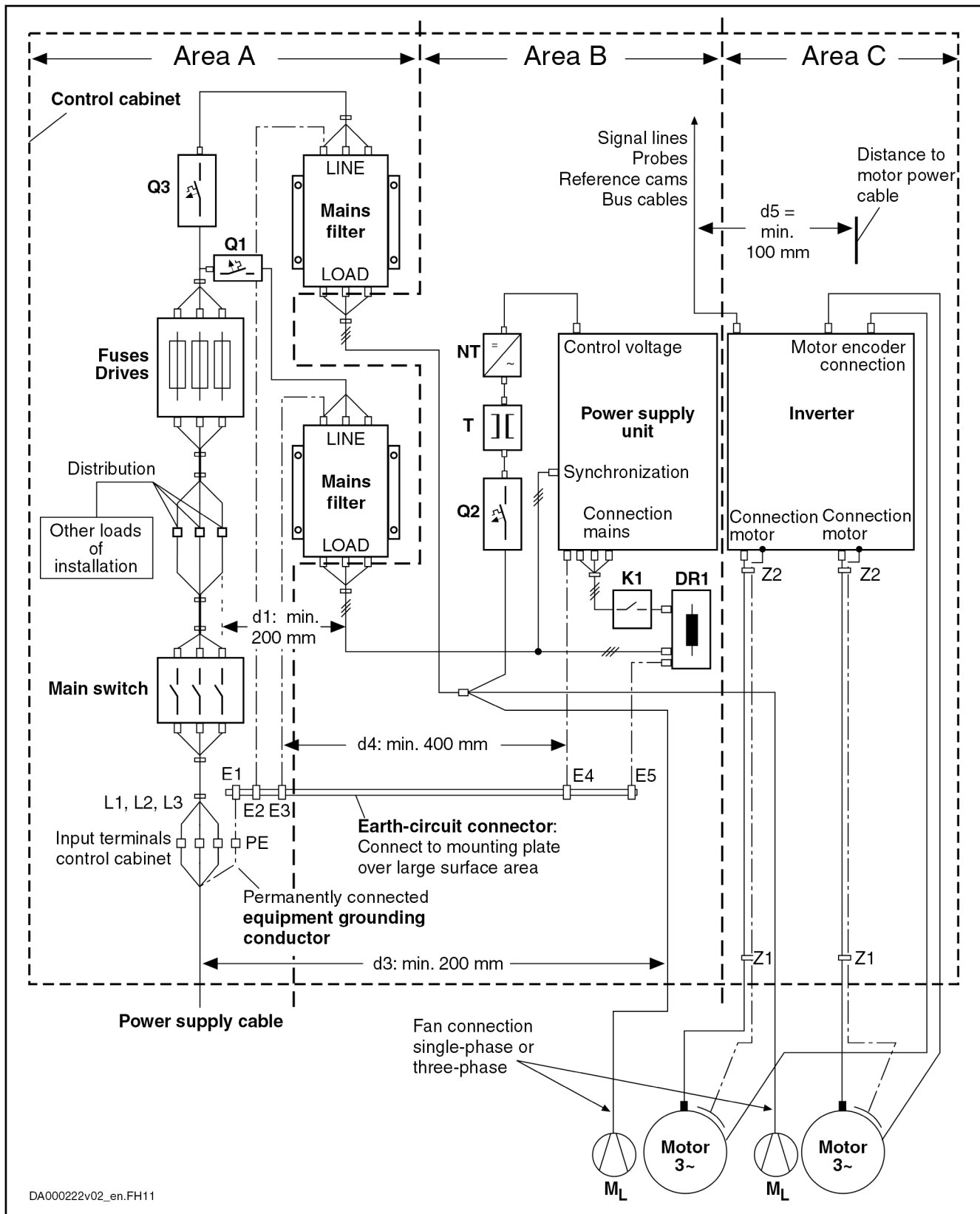

DA000222v02_en.FH11

- DR1 Mains choke
- E1...E5 Equipment grounding conductor of the components
- K1 External mains contactor for supply units without integrated mains contactor

Arranging the Components in the Control Cabinet

M _L	Motor fan
NT	Power supply unit
Q1, Q2, Q3	Fusing
T	Transformer
Z1, Z2	Shield connection points for cables
<i>Fig. 11-8:</i>	<i>EMC Areas in the Control Cabinet</i>

Design and Installation in Area A - Interference-Free Area of Control Cabinet**Arranging the Components in the Control Cabinet**

Comply with recommended distance of at least **200 mm** (distance d1 in the figure):

- Between components and electrical elements (switches, pushbuttons, fuses, terminal connectors) in the interference-free area A and the components in the two other areas B and C

Comply with recommended distance of at least **400 mm** (distance d4 in the figure):

- Between magnetic components (such as transformers, mains chokes and DC bus chokes that are directly connected to the power connections of the drive system) and the interference-free components and lines between mains and filter including the mains filter in area A

If these distances are not kept, the magnetic leakage fields are injected to the interference-free components and lines connected to the mains and the limit values at the mains connection are exceeded in spite of the installed filter.

Cable Routing of the Interference-Free Lines to the Mains Connection

Comply with recommended distance of at least **200 mm** (distance d1 and d3 in the figure):

- Between supply feeder or lines between filter and exit point from the control cabinet in area A and the lines in area B and C

If this is impossible, there are two alternatives:

1. Install lines in shielded form and connect the shield at several points (at least at the beginning and at the end of the line) to the mounting plate or the control cabinet housing over a large surface area.
2. Separate lines from the other interference-susceptible lines in areas B and C by means of a grounded distance plate vertically attached to the mounting plate.

Install the shortest possible lines within the control cabinet and install them directly on the grounded metal surface of the mounting plate or of the control cabinet housing.

Mains supply lines from areas B and C must not be connected to the mains without a filter.



In case you do not observe the information on cable routing given in this section, the effect of the mains filter is totally or partly neutralized. This will cause the noise level of the interference emission to be higher within the range of 150 kHz to 40 MHz and the limit values at the connection points of the machine or installation will thereby be exceeded. Consider the specified distances to be recommended data, provided that the dimensions of the control cabinet allow installing the lines accordingly.

Routing and Connecting a Neutral Conductor (N)

If a neutral conductor is used together with a three-phase connection, it must not be installed unfiltered in zones B and C, in order to keep interference off the mains.

Arranging the Components in the Control Cabinet

Motor Fan at Mains Filter	<p>Single-phase or three-phase supply lines of motor fans, that are usually routed in parallel with motor power cables or interference-susceptible lines, must be filtered:</p> <ul style="list-style-type: none"> • In drive systems with regenerative supply units, via a separate single-phase (NFE type) or three-phase filter (HNF type) near the mains connection of the control cabinet • In drive systems with only infeeding supply units, via the available three-phase filter of the drive system <p>When switching power off, make sure the fan is not switched off. When switching power off, make sure the fan is not switched off.</p>
Loads at Mains Filter of Drive System	<p> Only operate allowed loads at the mains filter of the drive system!</p> <p>At the three-phase filter for the power connection of regenerative supply units, it is only allowed to operate the following loads:</p> <ul style="list-style-type: none"> • HMV supply unit with mains choke and, if necessary, mains contactor <p>Do not operate any motor fans, power supply units etc. at the mains filter of the drive system.</p>
Shielding Mains Supply Lines in Control Cabinet	<p>If there is a high degree of interference injection to the mains supply line within the control cabinet, although you have observed the above instructions (to be found out by EMC measurement according to standard), proceed as follows:</p> <ul style="list-style-type: none"> • Only use shielded lines in area A • Connect shields to the mounting plate at the beginning and the end of the line by means of clips <p>The same procedure may be required for long cables of more than 2 m between the point of power supply connection of the control cabinet and the filter within the control cabinet.</p>
Mains Filters for AC Drives	<p>Ideally mount the mains filter on the parting line between the areas A and B. Make sure the ground connection between filter housing and housing of the drive controllers has good electrically conductive properties.</p> <p>If single-phase loads are connected on the load side of the filter, their current may be a maximum of 10% of the three-phase operating current. A highly imbalanced load of the filter would deteriorate its interference suppression capacity.</p> <p>If the mains voltage is more than 480 V, connect the filter to the output side of the transformer and not to the supply side of the transformer.</p>
Grounding	<p>In the case of bad ground connections in the installation, the distance between the lines to the grounding points E1, E2 in area A and the other grounding points of the drive system should be at least $d_4 = 400 \text{ mm}$, in order to minimize interference injection from ground and ground cables to the power input lines.</p> <p>See also Division Into Areas (Zones), page 204.</p>
Point of Connection for Equipment Grounding Conductor at Machine, Installation, Control Cabinet	<p>The equipment grounding conductor of the power cable of the machine, installation or control cabinet has to be permanently connected at point PE and have a cross section of at least 10 mm^2 or to be complemented by a second equipment grounding conductor via separate terminal connectors (according to EN 61800-5-1:2007, section 4.3.5.5.2). If the cross section of the outer conductor is bigger, the cross section of the equipment grounding conductor must be accordingly bigger.</p>

Arranging the Components in the Control Cabinet

Design and Installation in Area B - Interference-Susceptible Area of Control Cabinet**Arranging Components and Lines**

Modules, components and lines in area B should be placed at a distance of at least **d1 = 200 mm** from modules and lines in area A.

Alternative: Shield modules, components and lines in area B by distance plates mounted vertically on the mounting plate from modules and lines in area A or use shielded lines.

Only connect power supply units for auxiliary or control voltage connections in the drive system to the mains via a mains filter. See [Division Into Areas \(Zones\)](#), page 204.

Install the shortest possible lines between drive controller and filter.

Control Voltage or Auxiliary Voltage Connection

Only in exceptional cases should you connect power supply unit and fusing for the control voltage connection to phase and neutral conductor. In this case, mount and install these components in area A far away from the areas B and C of the drive system. For details see section [Design and Installation in Area A - Interference-Free Area of Control Cabinet](#), page 207.

Run the connection between control voltage connection of the drive system and power supply unit used through area B over the shortest distance.

Line Routing

Run the lines along grounded metal surfaces, in order to minimize radiation of interference fields to area A (transmitting antenna effect).

Design and Installation in Area C - Strongly Interference-Susceptible Area of Control Cabinet

Area C mainly concerns the motor power cables, especially at the connection point at the drive controller.

Influence of the Motor Power Cable

The longer the motor power cable, the greater its leakage capacitance. To comply with a certain EMC limit value, the allowed leakage capacitance of the mains filter is limited. For the calculation of the leakage capacitance, see the documentation on the drive system of the drive controller used.



- Run the shortest possible motor power cables.
- Only use **shielded** motor power cables by Rexroth.

Routing the Motor Power Cables and Motor Encoder Cables

Route the motor power cables and motor encoder cables along grounded metal surfaces, both inside the control cabinet and outside of it, in order to minimize radiation of interference fields. If possible, route the motor power cables and motor encoder cables in metal-grounded cable ducts.

Route the motor power cables and motor encoder cables

- with a distance of at least **d5 = 100 mm** to interference-free lines, as well as to signal cables and signal lines
(alternatively separated by a grounded distance plate)
- in separate cable ducts, if possible

Routing the Motor Power Cables and Mains Connection Lines

For converters (drive controllers with individual mains connection), route motor power cables and (unfiltered) mains connection lines **in parallel for a maximum distance of 300 mm**. After that distance, route motor power cables and power supply cables in opposite directions and preferably in separate **cable ducts**.

Ideally, the outlet of the motor power cables at the control cabinet should be provided in a distance of at least **d3 = 200 mm** from the (filtered) power supply cable.

Arranging the Components in the Control Cabinet

Converter - Routing the Motor Power Cables

With cable duct		Without cable duct	
<p style="text-align: right;">DE000021v02_nn.fh11</p>		<p style="text-align: right;">DE000020v02_nn.fh11</p>	
B	Area B	B	Area B
C	Area C	C	Area C
1	Cable duct for mains connection lines	1	Cable duct for mains connection lines
2	Shield connection of motor power cable via clips at least at one point; alternatively, at the device or on mounting plate at control cabinet	2	Shield connection of motor power cable via clips at least at one point; alternatively, at the device or on mounting plate at control cabinet
3	Cable duct for motor power cables	3	Control cabinet outlet of motor power cables
4	Parallel routing of mains connection lines and motor power cables over a maximum of 300 mm	4	Parallel routing of mains connection lines and motor power cables over a maximum of 300 mm
5	Distance of at least 100 mm or separated by a grounded distance plate	5	Distance of at least 100 mm or separated by a grounded distance plate
<p>Fig. 11-9: Routing of Motor Power Cables With Cable Duct</p>		<p>Fig. 11-10: Routing of Motor Power Cables Without Cable Duct</p>	

Tab. 11-7: Routing of Cables for Converter

Arranging the Components in the Control Cabinet

Inverter - Routing the Motor Power Cables

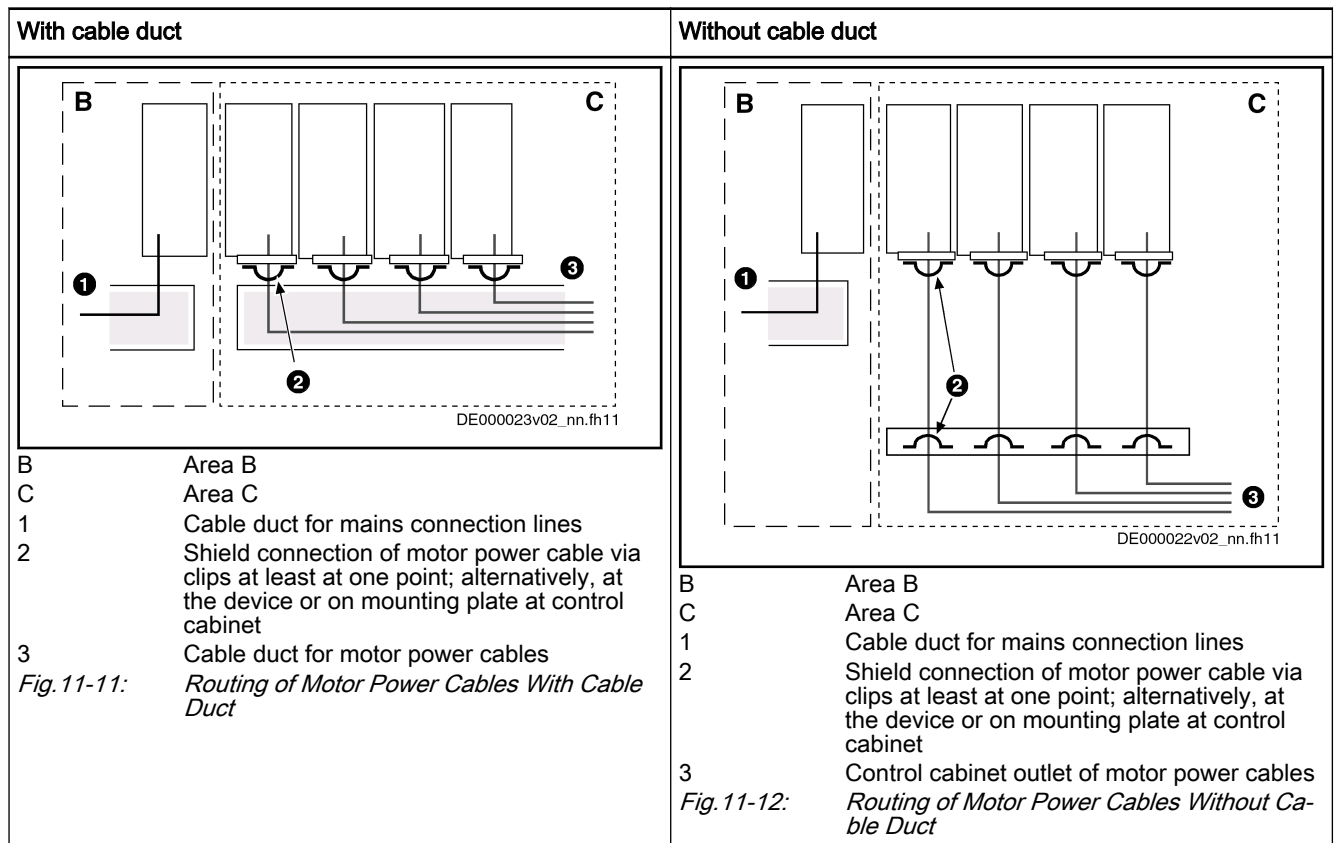

Tab. 11-8: Routing of Cables for Inverter

Ground Connections

Housing and Mounting Plate

By means of appropriate ground connections, it is possible to avoid the emission of interference, because interference is discharged to ground on the shortest possible way.

Ground connections of the metal housings of EMC-critical components (such as filters, devices of the drive system, connection points of the cable shields, devices with microprocessor and switching power supply units) have to be well contacted over a large surface area. This also applies to all screw connections between mounting plate and control cabinet wall and to the mounting of a ground bus to the mounting plate.

The best solution is to use a zinc-coated mounting plate. Compared to a varnished plate, the connections in this case have a good long-time stability.

Connection Elements

For varnished mounting plates, always use screw connections with tooth lock washers and zinc-coated, tinned screws as connection elements. At the connection points, remove the varnish so that there is safe electrical contact over a large surface area. You achieve contact over a large surface area by means of bare connection surfaces or several connection screws. For screw connections, you can establish the contact to varnished surfaces by using tooth lock washers.

Metal Surfaces

Always use connection elements (screws, nuts, plain washers) with good electroconductive surface.

Bare zinc-coated or tinned metal surfaces have **good electroconductive properties**.

Arranging the Components in the Control Cabinet

Ground Wires and Shield Connections	<p>Anodized, yellow chromated, black gunmetal finish or lacquered metal surfaces have bad electroconductive properties.</p> <p>For connecting ground wires and shield connections, it is not the cross section but the size of contact surface that is important, as the high-frequency interference currents mainly flow on the surface of the conductor.</p> <p>Always connect cable shields, especially shields of the motor power cables, to ground potential over a large surface area.</p>
--	---

Installing Signal Lines and Signal Cables

Line Routing	<p>For measures to prevent interference, see the Project Planning Manuals of the respective device. In addition, we recommend the following measures:</p> <ul style="list-style-type: none"> • Route signal and control lines separately from the power cables with a minimum distance of d5 = 100 mm (see Division Into Areas (Zones), page 204) or with a grounded separating sheet. The optimum way is to route them in separate cable ducts. If possible, lead signal lines into the control cabinet at one point only. • If signal lines are crossing power cables, route them in an angle of 90° in order to avoid interference injection. • Ground spare cables, that are not used and have been connected, at least at both ends so that they do not have any antenna effect. • Avoid unnecessary line lengths. • Run cables as close as possible to grounded metal surfaces (reference potential). The ideal solution are closed, grounded cable ducts or metal pipes which, however, is only obligatory for high requirements (sensitive instrument leads). • Avoid suspended lines or lines routed along synthetic carriers, because they are functioning like reception antennas (noise immunity) and like transmitting antennas (emission of interference). Exceptional cases are flexible cable tracks over short distances of a maximum of 5 m.
Shielding	<p>Connect the cable shield immediately at the devices in the shortest and most direct possible way and over the largest possible surface area.</p> <p>Connect the shield of analog signal lines at one end over a large surface area, normally in the control cabinet at the analog device. Make sure the connection to ground/housing is short and over a large surface area.</p> <p>Connect the shield of digital signal lines at both ends over a large surface area and in short form. In the case of potential differences between beginning and end of the line, run an additional bonding conductor in parallel. This prevents compensating current from flowing via the shield. The guide value for the cross section is 10 mm².</p> <p>You absolutely have to equip separable connections with connectors with grounded metal housing.</p> <p>In the case of non-shielded lines belonging to the same circuit, twist feeder and return cable.</p>

General Measures of Radio Interference Suppression for Relays, Contactors, Switches, Chokes and Inductive Loads

If, in conjunction with electronic devices and components, inductive loads, such as chokes, contactors, relays are switched by contacts or semiconductors, appropriate interference suppression has to be provided for them:

- By arranging free-wheeling diodes in the case of d.c. operation

Arranging the Components in the Control Cabinet

- In the case of a.c. operation, by arranging usual RC interference suppression elements depending on the contactor type, immediately at the inductance

Only the interference suppression element arranged immediately at the inductance does serve this purpose. Otherwise, the emitted noise level is too high which can affect the function of the electronic system and of the drive.

12 Project Planning of Cooling System

12.1 Control Cabinet

12.1.1 Control Cabinet Design and Cooling



The only mounting position allowed for supply units and drive controllers to be installed in control cabinets is G1.

Possibilities of Heat Dissipation

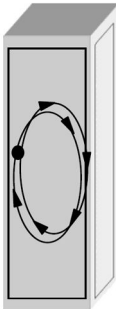
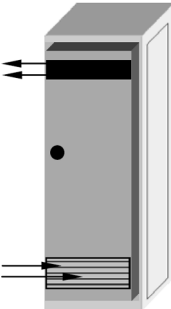
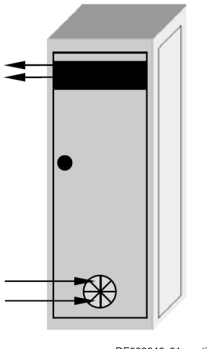
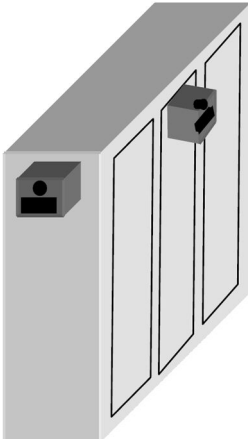
Closed control cabinet with air circulation	Closed control cabinet with heat exchanger	Control cabinet with fan	Closed control cabinet with air conditioning unit
 <p style="text-align: center; font-size: small;">DF000644v01_nn.tif</p>	 <p style="text-align: center; font-size: small;">DF000645v01_nn.tif</p>	 <p style="text-align: center; font-size: small;">DF000646v01_nn.tif</p>	 <p style="text-align: center; font-size: small;">DF000647v01_nn.tif</p>
$P_Q \sim 400 \text{ W}$	$P_Q \sim 1700 \text{ W}$	$P_Q \sim 2700 \text{ W}$	$P_Q \sim 4000 \text{ W}$

P_Q Dissipated heat output

Tab. 12-1: Possibilities of Heat Dissipation

The section below describes the "control cabinet with fan".

Requirements for Control Cabinets with Fan

NOTICE

Risk of damage by unclean air in the control cabinet!

Operating a control cabinet with a fan, but without the corresponding filters, can damage the devices or cause malfunction.

- Install filters at the air intake opening of the control cabinet so that impure air cannot get into the control cabinet.
- Service the filters at regular intervals according to the dust loading in the environment.
- Only replace the filters when the fan has been switched off, because otherwise the fan sucks in the dirt coming off the filter and the dirt gets into the control cabinet.

Project Planning of Cooling System

Control Cabinet Ventilation (Schematic Diagram)

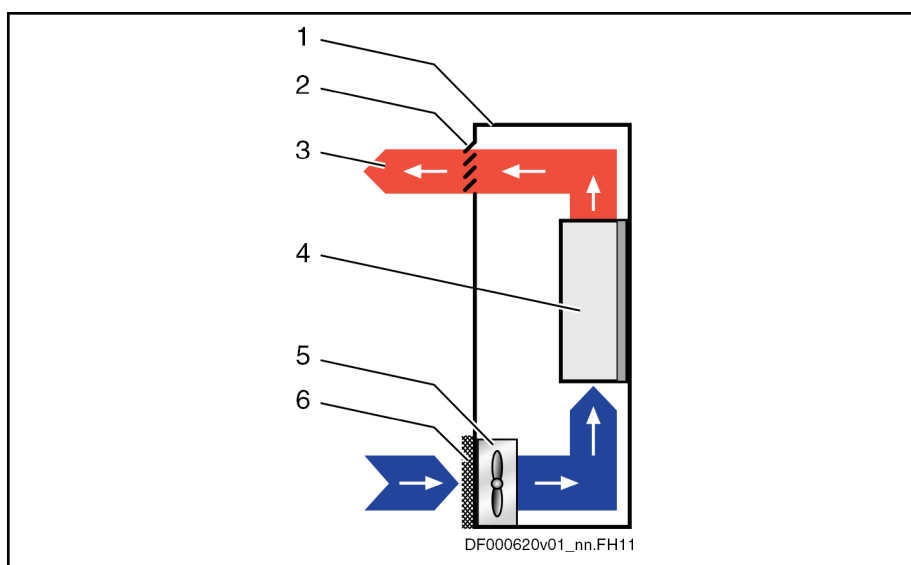

- | | |
|---|------------------------------|
| 1 | Control cabinet |
| 2 | Air outlet opening |
| 3 | Heat discharge |
| 4 | Device in control cabinet |
| 5 | Control cabinet fan |
| 6 | Filter at air intake opening |

Fig. 12-1: Control Cabinet Ventilation (Schematic Diagram)

Only clean air gets into the control cabinet through the filter at the air intake opening. The control cabinet fan behind the air intake opening delivers the air into the control cabinet and generates overpressure in the control cabinet. This overpressure prevents unclean air from entering into the control cabinet through potentially leaky points (leaky cable passages, damaged seals, etc.).

12.1.2 Arranging the Cooling Units

Unless the nominal data are reduced, the drive controller may only be operated up to a specified maximum ambient temperature. A cooling unit might therefore be required.

NOTICE

Possible damage to the drive controller! Operational safety of the machine endangered!

Observe the instructions below.

Avoiding Dripping or Spraying Water

Due to their operating principle, condensation water is formed when cooling units are used.

For this reason, observe the following aspects:

- Always position cooling units in such a way that condensation water cannot drip onto the devices in the control cabinet.
- Position the cooling unit in such a way that the fan of the cooling unit does not spray accumulated condensation water onto the devices in the control cabinet. Mount the air duct in the control cabinet accordingly.

Project Planning of Cooling System

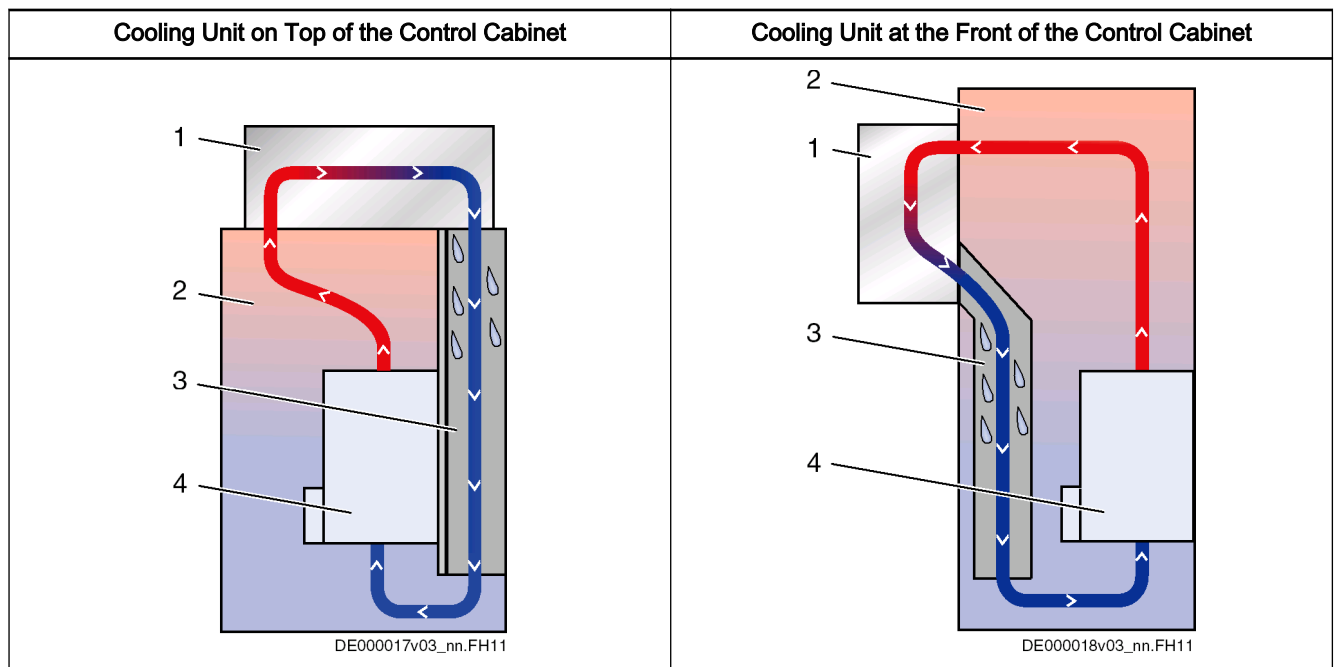

- 1 Cooling unit
- 2 Interior of control cabinet
- 3 Air duct (protects devices against condensation water)
- 4 Device in control cabinet

Tab. 12-2: Arranging the Cooling Units

Avoiding Moisture Condensation

Moisture condensation occurs when the temperature of the device is lower than the ambient temperature.

- Set cooling units with temperature adjustment to the maximum surrounding temperature and not lower!
- Set cooling units with follow-up temperature in such a way that the interior temperature of the control cabinet is not lower than the temperature of the surrounding air. Set the temperature limitation to the maximum surrounding temperature!
- Only use well-sealed control cabinets so that moisture condensation cannot arise as a result of warm and moist external air entering the cabinet.
- In the event that control cabinets are operated with the doors open (commissioning, servicing etc.), it is essential to ensure that after the doors are closed the drive controllers cannot at any time be cooler than the air in the control cabinet. For this reason, sufficient circulation must be provided inside the control cabinet.

Project Planning of Cooling System

12.1.3 Multiple-Line Design of the Control Cabinet

**Arrangement of the devices, air guides/drip protections, fans**

Pay particular attention to the maximum allowed air intake temperature of devices when they are arranged in multiple lines in the control cabinet.

If possible, place devices with a high degree of power dissipation (e.g. supply units with braking resistors, DC bus resistor units)

- in the top line and
- near the outlet air aperture to the cooling unit

Mount **air guides** between the lines to

- protect the devices in the upper lines against the warm outlet air of the devices beneath and
- protect the devices beneath against penetration of liquids (e.g. dripping condensation water or leaking cooling liquid)

Additional fans convey the outlet air to the cooling unit and cooling air to the upper lines.

At the installed control cabinet, check the air intake temperature of all devices.



To extend the module bus connection, the accessory RKB0001 is available. Observe the assignment.

Project Planning of Cooling System

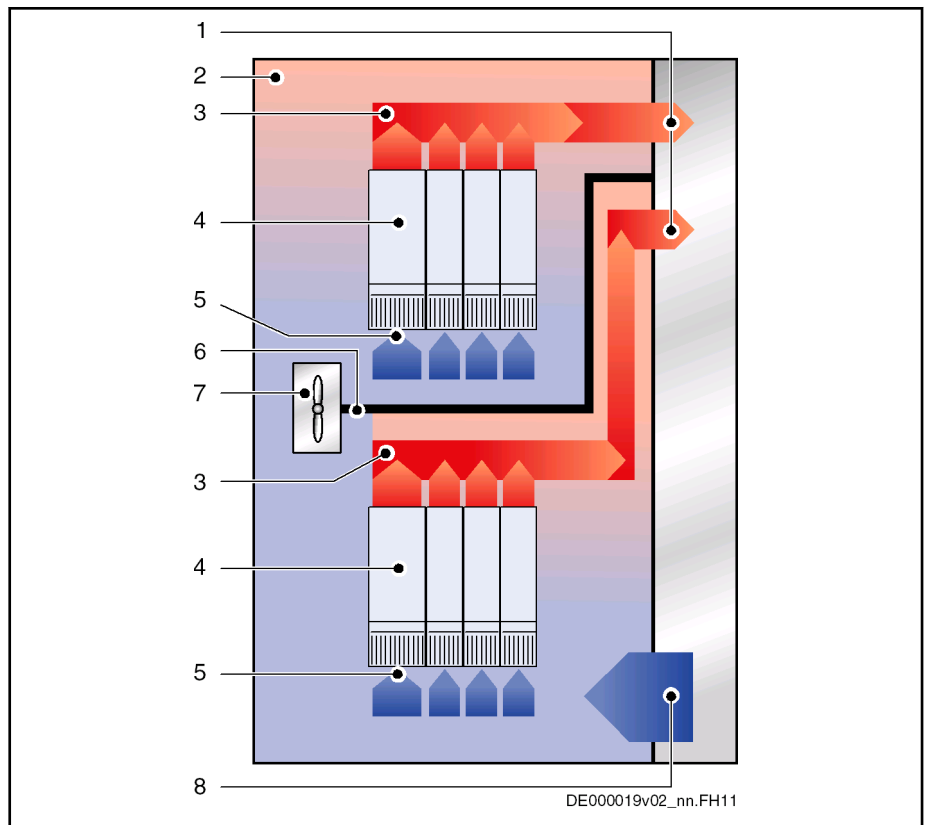

- 1 Discharge of heated air to cooling unit
- 2 Interior of control cabinet
- 3 Conveying direction of heated air in area where air flows off
- 4 Device in control cabinet
- 5 Air intake at device
- 6 Air guide in control cabinet (for liquid cooling, this is also the drip protection for the devices beneath)
- 7 Fan in control cabinet
- 8 Supply of cooled air from cooling unit

Fig. 12-2: Example of Arrangement for Double-Line Design

13 Connections of the Components in the Drive System

13.1 System Connections of the Components

13.1.1 General Information

Electrical connections for operating the drive system Rexroth IndraDrive:

In the System Environment

- Connection X3 or PE to equipment grounding system
- Connection X3 to supply with power voltage
- Connection X13 or terminal block 0V / +24V to supply with control voltage
- Connection to control unit and/or master communication

Within the Drive System

- Equipment grounding conductor connections PE to X3 or joint bars at the devices
- DC bus connections L+ with bars
- DC bus connections L- with bars
- Control voltage connections 0V with bars
- Control voltage connections +24V with bars
- Module bus connections X1 with ribbon cable
- Motor power connections via motor power cable at X5
- Connections for motor temperature monitoring and motor holding brake via motor power cable at X6

Connections of the Components in the Drive System

13.1.2 Position of System Connections

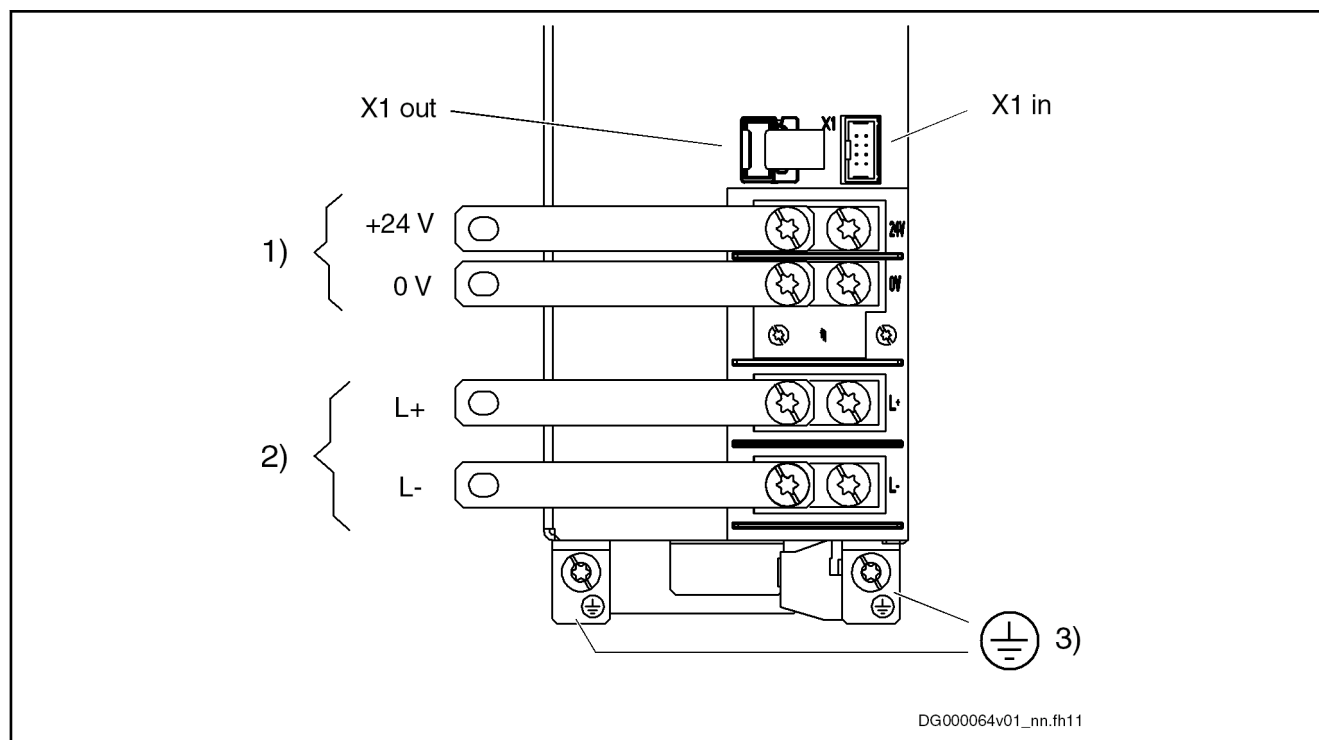

- 1) Control voltage
 2) DC bus
 3) Equipment grounding conductor
 X1 out, X1 in Module bus

Fig. 13-1: Connections at Power Section

13.1.3 Ground Connection of Housing

The ground connection of the housing is used to provide functional safety of the drive controllers and protection against contact in conjunction with the equipment grounding conductor.



Avoid spark discharge of static charges!

In some applications (e.g. printing or packaging), high static charges can develop. Make sure that these charges can be directly discharged against ground at their point of origin. If necessary, install additional lines between the fixing points of the motor flanges (charge acceptance) and the ground connection of the drive system (e.g. mounting surface of the drive controllers in the control cabinet).

Ground the housings of the devices:

1. Connect the bare metal back panel of the device in conductive form to the mounting surface in the control cabinet. To do this, use the supplied mounting screws.
2. Connect the mounting surface of the control cabinet in conductive form to the equipment grounding system.
3. Connect the bare metal back panel of the mains filter in conductive form to the mounting surface in the control cabinet. Connect the mounting surface of the mains filter with the lowest possible impedance (over a

Connections of the Components in the Drive System

large surface area) to the mounting surface of the drive controllers (see item 1).

13.1.4 Connection Point of Equipment Grounding Conductor and Equipment Grounding Connections

General Information

The connection of the equipment grounding conductors of the devices and their connection to the equipment grounding system are indispensable for the electrical safety of the drive system.

⚠ WARNING	Dangerous contact voltage at device housing! Lethal electric shock!
------------------	--

The devices of the Rexroth IndraDrive product range are devices with increased leakage current (greater than AC 3.5 mA or DC 10 mA). Therefore, always install a stationary connection of the equipment grounding conductor.

Observe the description below.

In the drive system Rexroth IndraDrive, connect the equipment grounding conductor connections of all devices and additional components to the equipment grounding system.

Involved devices	Equipment Grounding Connections Between Devices		Connection to equipment grounding system in control cabinet at devices	
HMV01 HCS03 HMS01 HMD01 HLB01.1D HLC01.1D HLC01.1C	Interconnect joint bars at front of devices	HMV01 HCS03 HMS01 HMD01 HLB01.1D HLC01.1D HLC01.1C	Realized in central form One connection at	HMV01 HCS03
HCS02 with HAS04 HLB01.1C HLC01.1C HMS01 HMD01		Interconnect joint bars at front of devices	HAS04 HLB01.1C HLC01.1C HMS01 HMS02 HMD01	Realized in central form One connection at
HCS02 without HAS04 HCS02 HMS01 HMS02 HMD01 HLB01.1C HLC01.1C HLB01.1D HLC01.1	Interconnect joint bars at front of devices		HMS01 HMS02 HMD01 HLB01.1C HLC01.1C HLB01.1D HLC01.1D	One connection each at all and one connection at connected drive system, consisting of all

Connections of the Components in the Drive System

Involved devices	Equipment Grounding Connections Between Devices		Connection to equipment grounding system in control cabinet at devices	
	HMV02 HMS02 HNL02 HNS02	Interconnect joint bars at front of devices	HMV02 HMS02	One connection each at all and one connection at connected drive system, consisting of all

Tab.13-1: Equipment Grounding Connections

Equipment Grounding Connections Between Devices

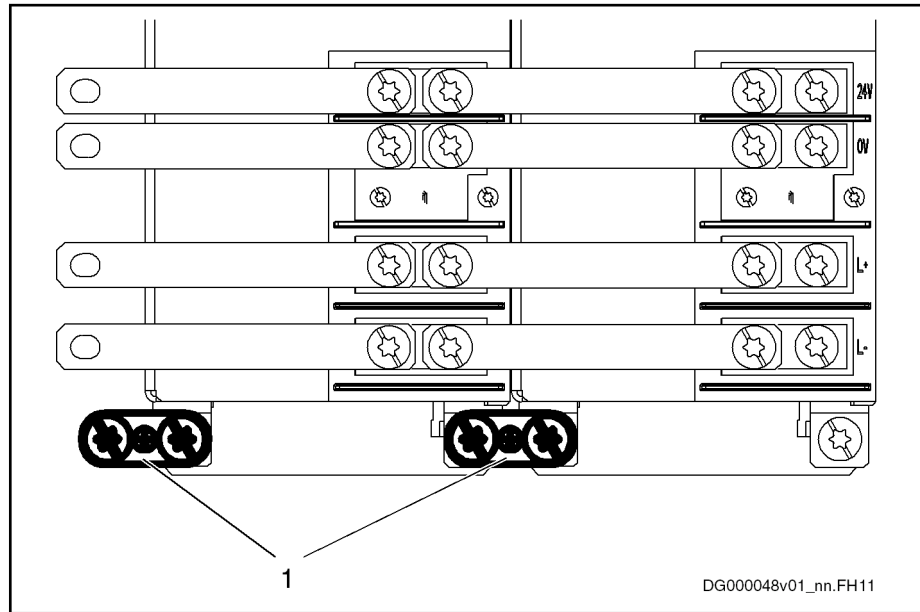

1 Joint bar

Fig.13-2: Equipment Grounding Connections Between Devices

DG000048v01_nn.FH11

Connections of the Components in the Drive System

Connection to Equipment Grounding System in Control Cabinet

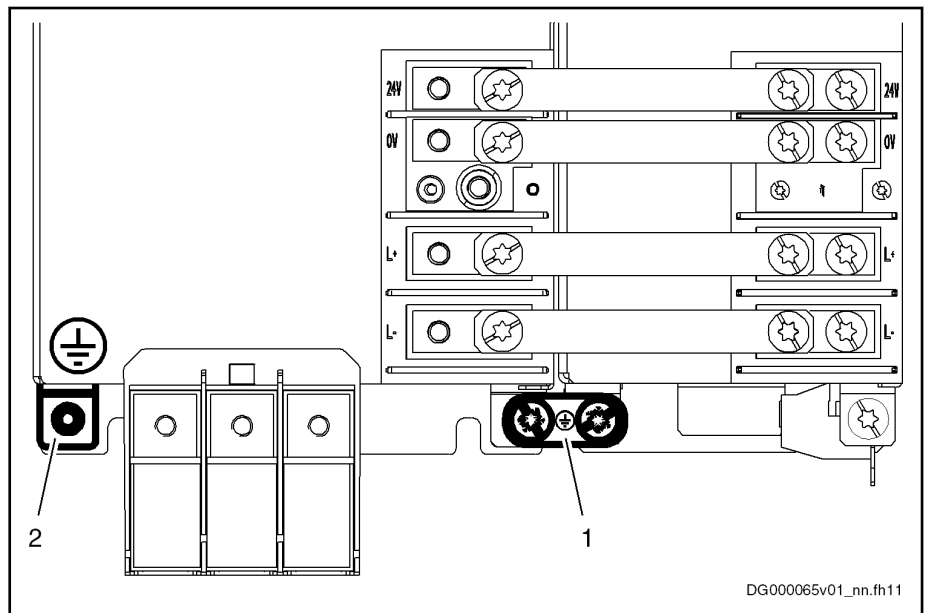

- 1 Joint bar
- 2 Connection point for connection to equipment grounding system in control cabinet

Fig. 13-3: Equipment Grounding Connections

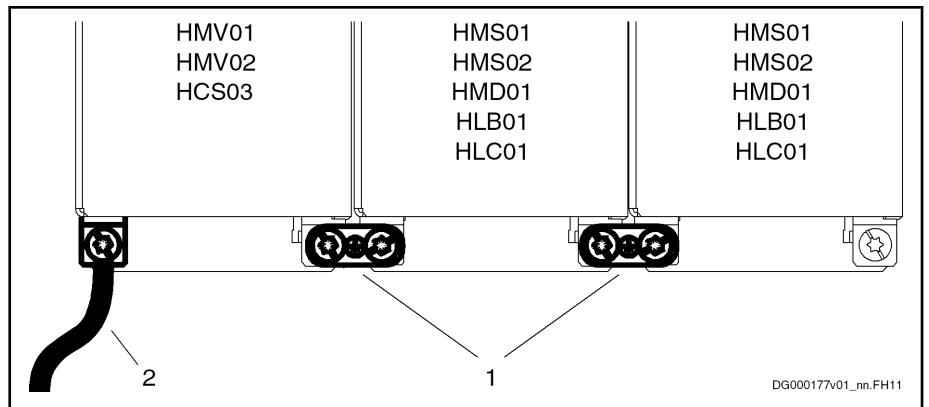

- 1 Joint bar
- 2 Connection to equipment grounding system

Fig. 13-4: Equipment Grounding Connection in the Case of Supply via HMV01, HMV02 or HCS03

Connections of the Components in the Drive System

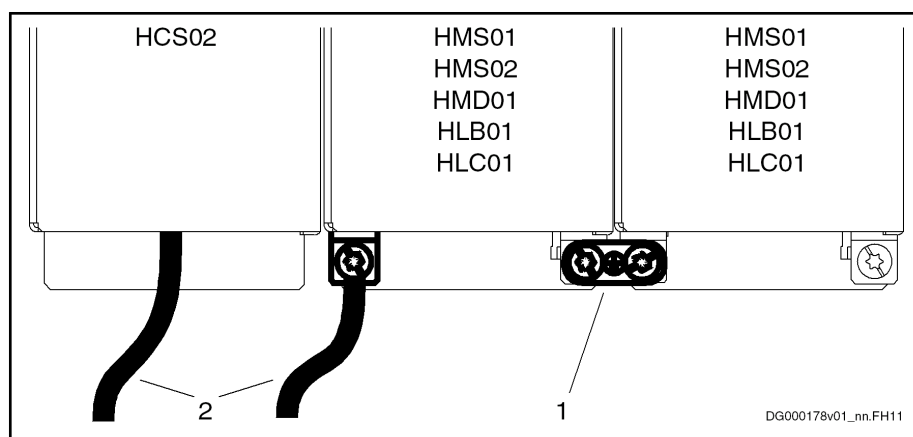

- 1 Joint bar
2 Connection to equipment grounding system

Fig.13-5: Equipment Grounding Conductor Connection for Supply via HCS02



Equipment grounding conductor: Material and cross section

For the equipment grounding conductor, use the same metal (e.g. copper) as for the outer conductors.

For the connections from the equipment grounding conductor connection of the device to the equipment grounding conductor system in the control cabinet, make sure the cross sections of the lines are sufficient.

Cross sections of the equipment grounding connections:

- For **HCS03.1E** drive controllers, **HMV01** and **HMV02** supply units at least **10 mm² (AWG 8)**, but not smaller than the cross sections of the outer conductors of the mains supply feeder
- For **HCS02.1E** drive controllers, **at least 4 mm² (AWG 10)**, but not smaller than the cross sections of the outer conductors of the mains supply feeder

Additionally, mount the housing of HCS02.1E to a bare metal mounting plate. Connect the mounting plate, too, with at least the same cross section to the equipment grounding conductor system in the control cabinet.

For outer conductors with a cross section greater than 16 mm², you can reduce the cross section of the equipment grounding connection according to the table "Equipment Grounding Conductor Cross Section".

Cross-sectional area A of outer conductors	Minimum cross-sectional area A _{PE} of equipment grounding connection
$A \leq 16 \text{ mm}^2$	A
$16 \text{ mm}^2 < A \leq 35 \text{ mm}^2$	16
$35 \text{ mm}^2 < A$	A / 2

Tab.13-2: Equipment Grounding Conductor Cross Section

13.1.5 Connection to Mains Choke and Mains Filter

Order of the connections to the supply mains:

Connections of the Components in the Drive System

Supply mains → mains filter → mains choke → supply unit or drive controller



Only operate allowed loads at the mains filter of the drive system!

At the three-phase filter for the power connection of regenerative supply units, it is only allowed to operate the following loads:

- HMV supply unit with mains choke and, if necessary, mains contactor

Do not operate any motor fans, power supply units etc. at the mains filter of the drive system.

The cables to the mains choke and mains filter carry a high potential of interference; you should therefore keep them as short as possible and twist them.



Allowed cable length between the components mains filter ↔ mains choke and mains choke ↔ supply unit (X3, X14):

At most 2 m for each cable (unshielded; twisted or run in grounded, metallic channel)

Shielded cables (with a cable shield connected over a large surface are at both ends) may be longer than 2 m. In total, the entire cable length ([mains filter ↔ mains choke] + [mains choke ↔ supply unit]) must be less than 10 m.

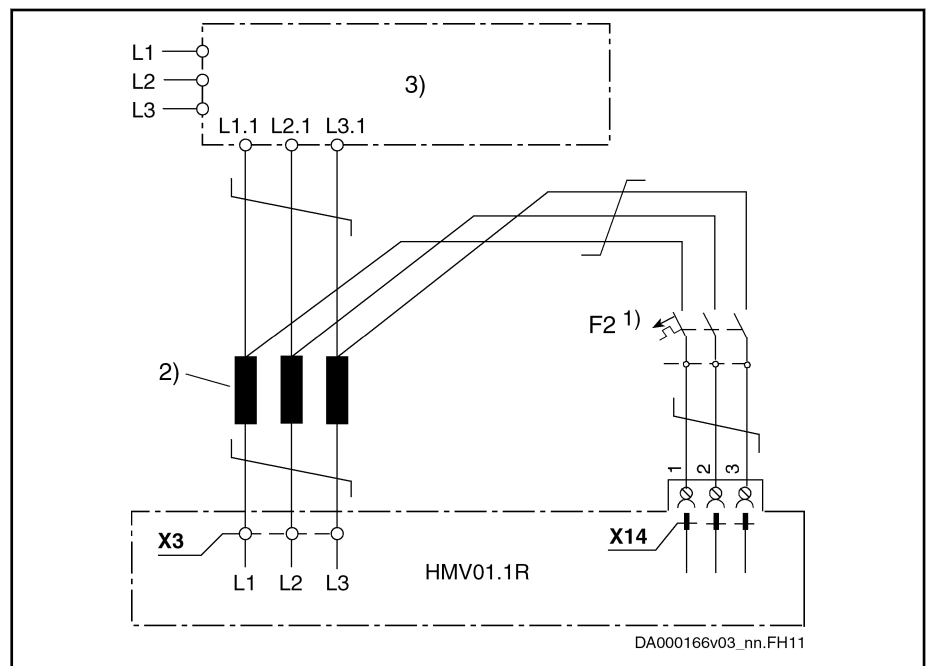

- 1) Fusing of connection X14
- 2) Mains choke
- 3) Mains filter

Fig. 13-6: Synchronizing Voltage by the Example of HMV01.1R

Other circuits for the mains connection: See [chapter 9 "Circuits for the Mains Connection"](#) on page 141

Connections of the Components in the Drive System

13.1.6 Connection of the DC Bus Connections

General Information

NOTICE

Property damage in case of error caused by too small line cross section!

Observe the **current carrying capacity of the connection lines** at the DC bus connections of the components used; see chapter "DC Bus Connection (L+, L-)" in the Project Planning Manual "Rexroth IndraDrive Supply Units and Power Sections".

Install connection lines at the DC bus connections in such a way that they are protected by the line protection at the mains connection of the supply unit or by additional fuses before the connection line.

Technical Data of the Connection Point

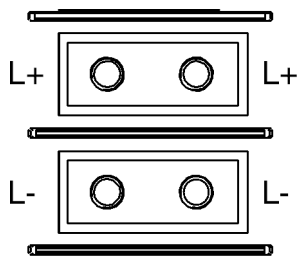
View	Identifica- tion	Function	
 DA000176v01_nn.FH11	L+	Connection points for connecting DC bus connections	
	L-		
Screw connection	Unit	Min.	Max.
M6 thread at device (terminal block)			
Tightening torque	Nm	5,5	6,5
Short circuit protection		Via fusing elements connected in the incoming circuit to the mains connection	
Overload protection		Via fusing elements connected in the incoming circuit to the mains connection	
Current carrying capacity "looping through" from L+ to L+, L- to L- (contact bars in scope of supply of accessory HAS01)			
With contact bars -072	A		220
Additionally with contact bars -042 and end piece	A		245

Tab. 13-3: Function, Pin Assignment, Properties

Single-Line Arrangement

The figure below illustrates the connection point and connection of the DC bus connections in the case of single-line arrangement **with contact bars** for the system components

- HMV01
- HMS01
- HMD01

Connections of the Components in the Drive System

- HLB01.1D
- HCS03

Design

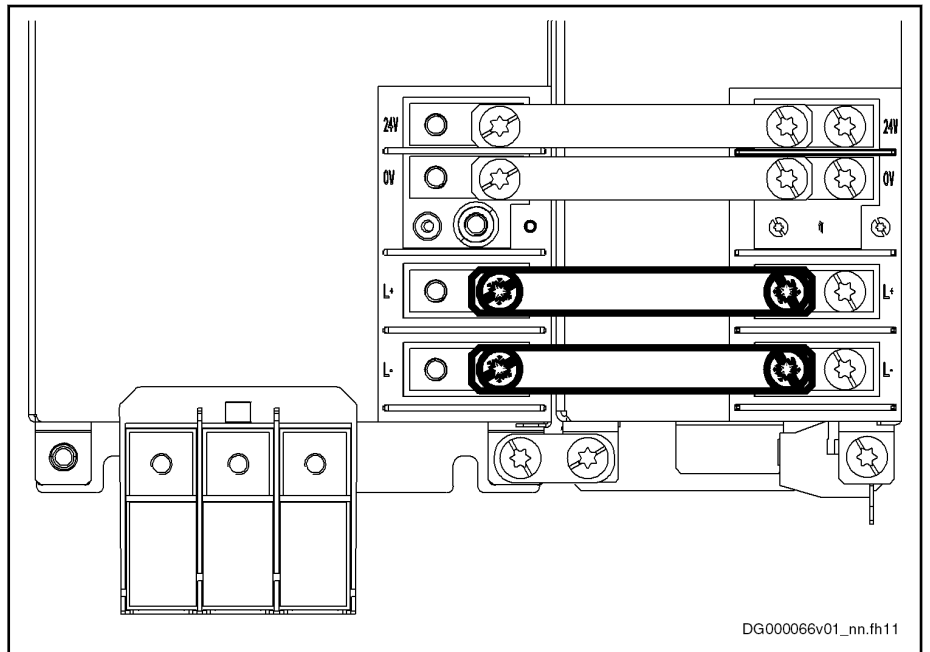

Fig. 13-7: Contact bars

Multiple-Line Arrangement

For multiple-line arrangement of drive controllers, the connection for DC bus and control voltage supply is realized **with twisted cables**.

NOTICE	Risk of damage to the drive controller!
<ul style="list-style-type: none"> • The DC bus connections of stacked drive controllers must be correctly interconnected. • Connect L+ connections only to other L+ connections and L- connections only to other L- connections. • Observe the measures regarding maximum allowed line lengths and minimum required line cross sections. 	

Minimum Requirements to Connection Lines

- | | |
|----------------------------|---|
| Dielectric Strength | <p>The connection lines from the supply unit to the drive systems and between the drive systems must have a dielectric strength of at least:</p> <ul style="list-style-type: none"> • 1000 V against each other • 700 V against ground |
| Line Cross Section | <p>Determine the minimum line cross section from supply unit to drive systems and between drive systems by means of the rated current. For rated current, use the higher value from the following calculations:</p> <ul style="list-style-type: none"> • Calculate the mains-side phase current • Calculate the current in the branch with the greatest DC bus power |



Minimum cross section UL

Use in the scope of UL requires the line cross section $A \geq 35 \text{ mm}^2$ (AWG2).

Connections of the Components in the Drive System



For connecting line cross sections of **35 mm²** (AWG2) and **50 mm²** (AWG1/0), use the accessory **HAS05.1-004**.

Routing

Routing of the connection lines from the supply unit to drive systems and between the drive systems:

- **Twist** the lines with the minimum possible length of lay, but 120 mm as a maximum
- With minimum mechanical distance to ground potential
- With a distance of at least 200 mm to control voltage lines

The figures below illustrate the correct DC bus connection for stacked drive controllers. The illustrated way of connection keeps bare wire sections from being situated directly vis-à-vis. This avoids voltage arcing.

Maximum Allowed Line Length at DC Bus Connection

The line length at the DC bus connection is limited to protect the devices. For the maximum allowed line lengths between the electrical connections, see table below.

Allowed line length / m								
From	To							
	HMV01	HMV02	HCS03	HCS02	HMS01 / HMD01	HMS02	HLB01	HLC01
HMV01	0,5	--	--	--	2 ¹⁾	--	0,35	0,35
HMV02	--	0,5	--	--	--	0,35	0,35	0,35
HCS03	--	--	0,5	--	2 ¹⁾	--	--	0,35
HCS02	--	--	--	0,5	2 ¹⁾	0,35	0,35	0,35
HMS01 / HMD01	--	--	--	--	2 ¹⁾	--	0,35	0,35
HMS02	--	--	--	--	--	2 ¹⁾	0,35	0,35
HLB01	--	--	--	--	--	--	0,35	0,35
HLC01	--	--	--	--	--	--	--	0,35
HLL02	-	2	-	-	-	2	-	-

¹⁾ Additional lateral distance requires the module bus connection RKB0001

Tab. 13-4: *Maximum Allowed Line Lengths at DC Bus*

**Line length > 2 m between supply unit and drive controller**

For arrangements of supply units which supply, for example, drive controllers over line lengths > 2 m, take special measures:

- Use HLC01 DC bus capacitor units at every drive system.
- Dimension the minimum size of HLC01 according to the projected continuous power of the respective drive system: 47 µF per kilowatt [kW] of continuous power.

Example: 50 kW calculated continuous power in DC bus requires 2350 µF at this system, thus at least 1 HLC01.1D-02M4.

Connections of the Components in the Drive System



Maximum length between drive systems and drive controllers

Multiple-line arrangement or distance between the devices requires the accessory **RKB0001** for the **module bus connection** between the devices.

The maximum length of the accessory RBK0001 limits the length of the DC bus connection to be achieved between drive systems.

Cable Routing to the Left

NOTICE

Damage caused by voltage arcing!

Insulate ring terminals and connection lines with a heat-shrinkable sleeve. Afterwards, only strip the insulation of the contact surface of the ring terminal. Make connections according to figure.

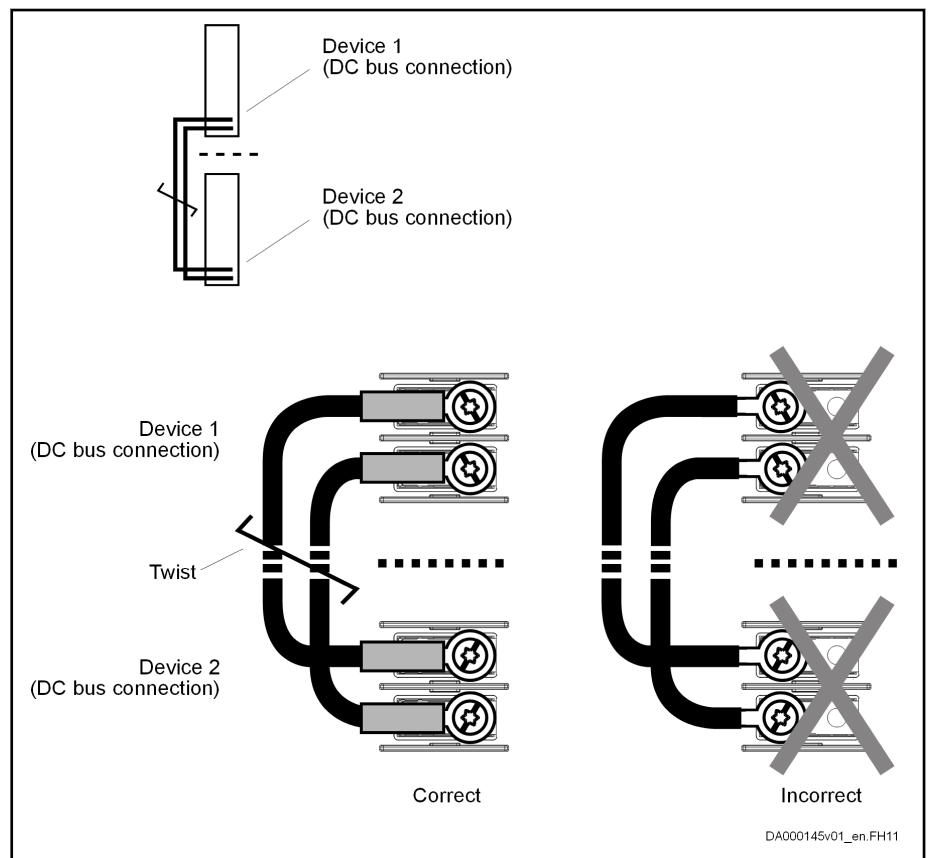

Fig.13-8: DC Bus Connections for Cable Routing to the Left

Cable Routing to the Right

NOTICE

Damage caused by voltage arcing!

Insulate ring terminals and connection lines with a heat-shrinkable sleeve. Afterwards, only strip the insulation of the contact surface of the ring terminal.

Connections of the Components in the Drive System

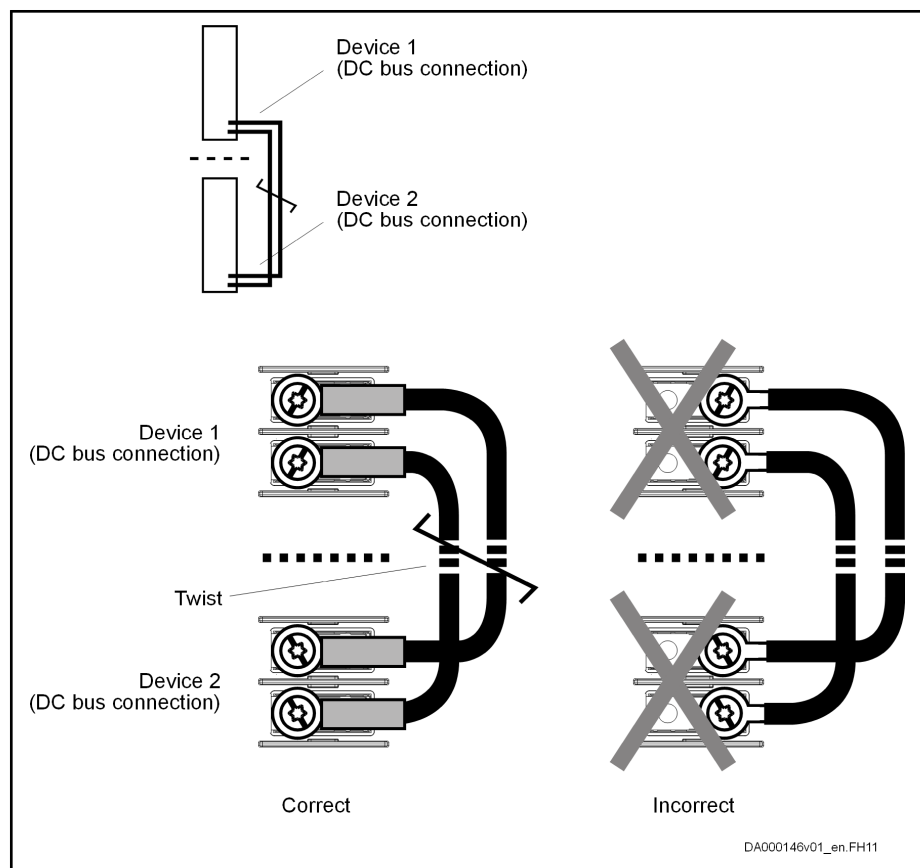

Fig. 13-9: DC Bus Connections for Cable Routing to the Right

13.1.7 Connection of the Control Voltage Connections

General Information

NOTICE

Property damage in case of error caused by too small line cross section!

Make use of the contact bars provided to loop-through.

Observe the current carrying capacity of the connections for 24V supply at the devices used; see sections "Terminal Block, 24 - 0V (24V Supply)" and "X13, Control Voltage" in the "Project Planning Manual "Rexroth IndraDrive Supply Units and Power Sections"".



Connect the connections X13 of components with connector for 24V supply individually and in star-shaped form to the 24V supply in the control cabinet.

Connections of the Components in the Drive System

Technical Data of the Connection Point

View	Identifica- tion	Function	
<p>DA000175v01_nn.FH11</p>	+24V	Power supply Connection to neighboring devices with contact bars from accessory HAS01.1	
	0V	Reference potential for power supply Connection to neighboring devices with contact bars from accessory HAS01.1	
Screw connection	Unit	Min.	Max.
M6 thread at device (terminal block)			
Tightening torque	Nm	5,5	6,5
Power consumption	W	P _{N3} (see technical data)	
Voltage load capacity	V	U _{N3} (see technical data)	
Polarity reversal protection		Within the allowed voltage range by internal protective diode	
Current carrying capacity "looping through" from 24V to 24V, 0V to 0V (contact bars in scope of supply of accessory HAS01)			
With contact bars -072	A	220	

Tab. 13-5: Function, Pin Assignment, Properties

Single-Line Arrangement

The figure below illustrates the connection point and connection of the control voltage connections for devices HMV01, HMV02, HMS01, HMS02, HMD01 HLB01.1D and HCS03 in single-line arrangement.

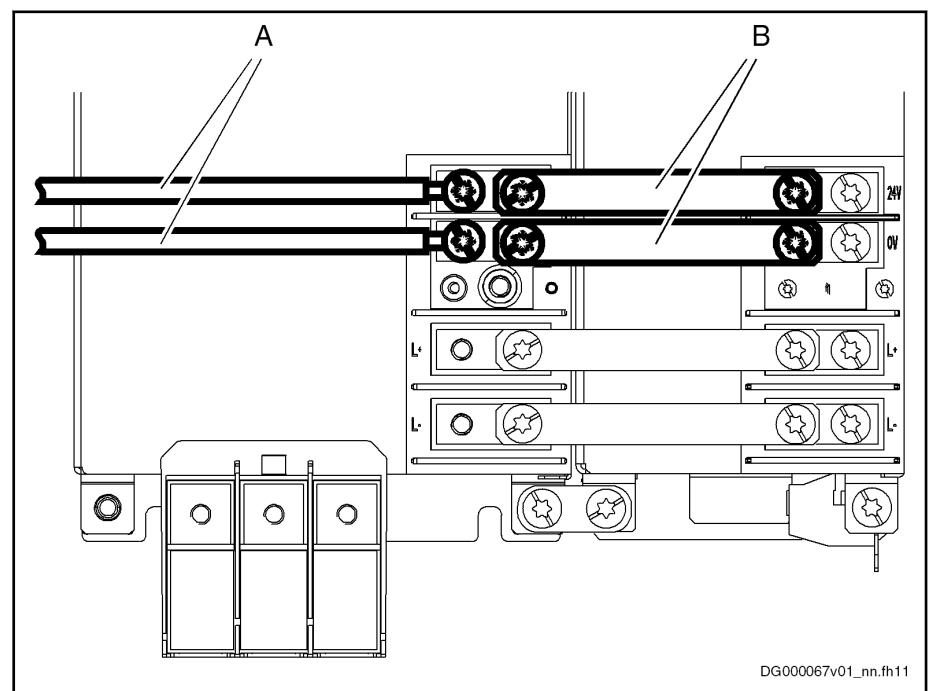

- A Cable (to source of control voltage supply)
- B Contact bars

Fig. 13-10: Connection Points and Connections of Control Voltage

Connections of the Components in the Drive System

Multiple-Line Arrangement The following figures show the correct control voltage connection for stacked drive controllers. The illustrated way of connection ensures that the touch guard can be correctly mounted and the required clearances and creepage distances can be complied with.

The cables must be twisted.

Cable Routing to the Left

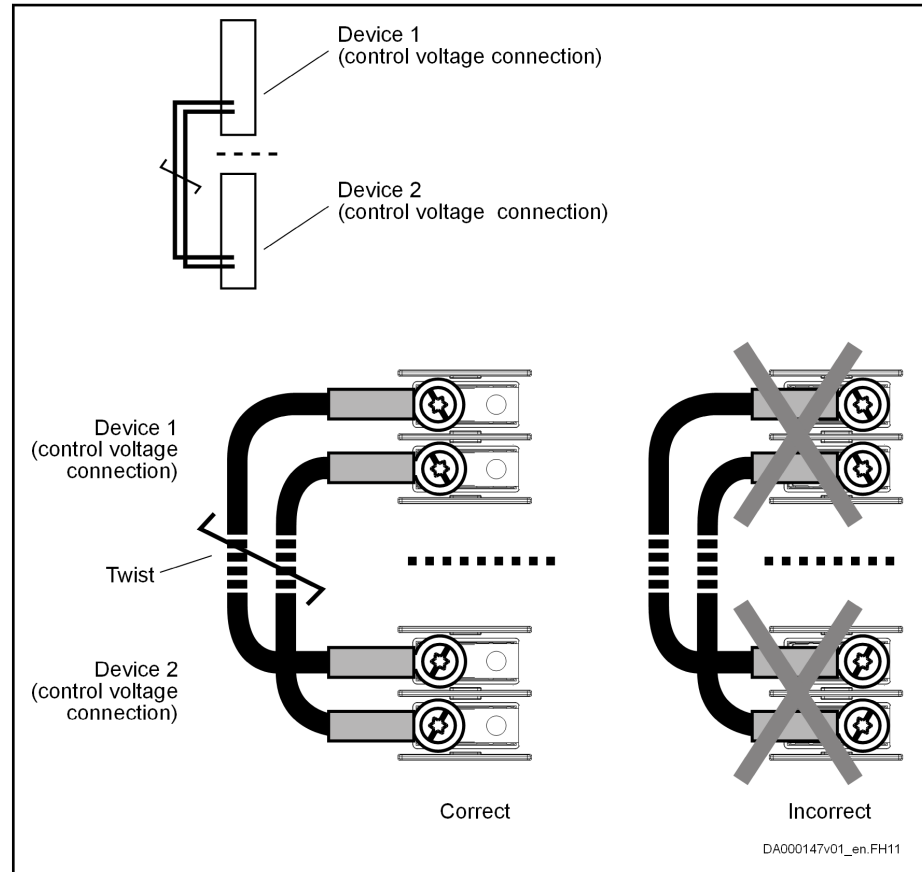

Fig.13-11: Control Voltage Connections for Cable Routing to the Left

Connections of the Components in the Drive System

Cable Routing to the Right

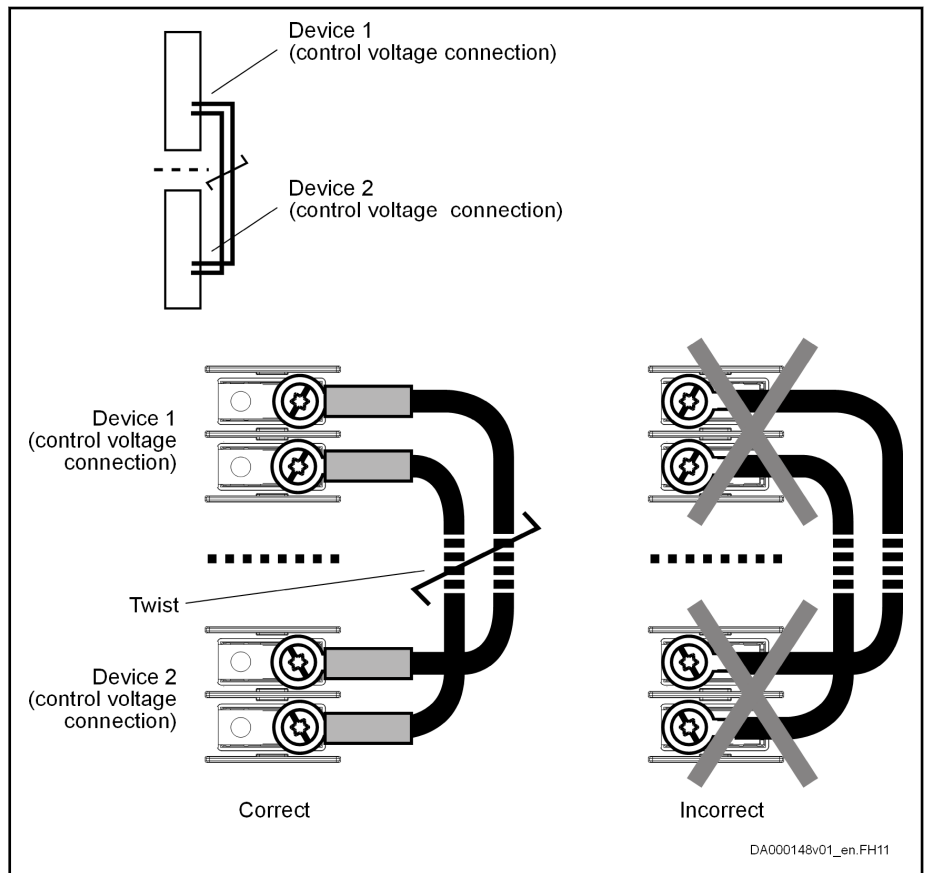

Fig.13-12: Control Voltage Connections for Cable Routing to the Right

13.1.8 Module Bus Connection X1

The module bus connection is used for signal exchange within the drive system and takes place via the supplied ribbon cables.

Graphic Representation

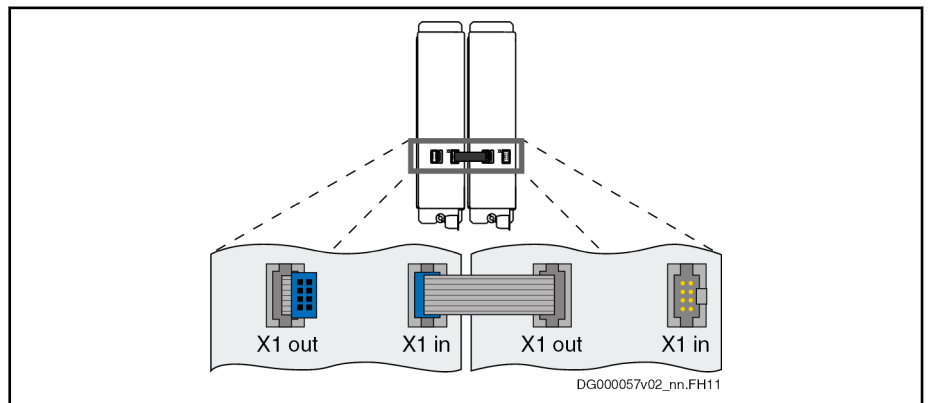

Fig.13-13: X1



When extension cables are used for the module bus, they must be **shielded**. Their total length mustn't exceed a **maximum of 40 m**.

To extend the module bus connection, the accessory **RKB0001** is available.

Connections of the Components in the Drive System

13.1.9 Connection of Motor to Drive Controller

General Information

The connection to the motor is made with Rexroth motor power cables.

The motor power cables contain:

Connection X5 (power)

- Outputs to motor A1, A2, A3
- Equipment grounding conductor connection
- Overall shield

Connection X6 (control contacts)

- Motor temperature monitoring with partial shield
- Motor holding brake with partial shield

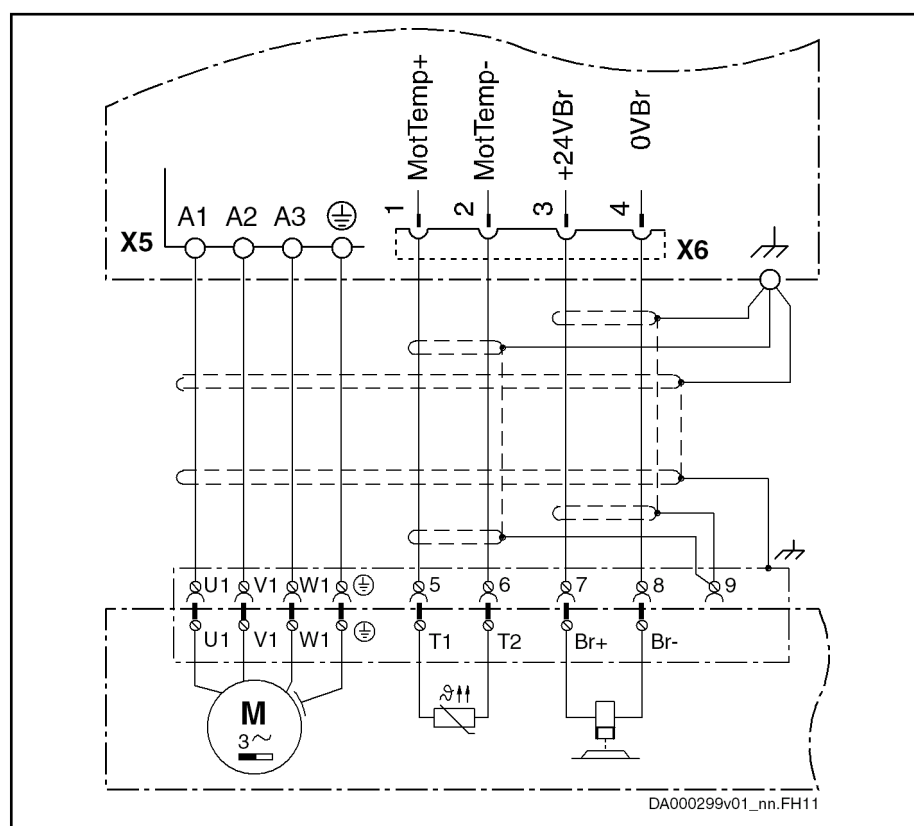



Fig. 13-14: Motor connection

 For detailed information, particularly on suitable additional parts, such as control cabinet ducts and extensions, see documentation "Rexroth Connection Cables".

Minimum requirements for connecting the motor power cables to the drive controller:

- Connect the shield of the motor power cable **over the largest possible surface area (with low impedance)** to the drive controller. The connection of cable shields by means of round wires (so-called "pig tails") at the cable ends to ground and housing is normally insufficient.
- Make sure there is sufficient **strain relief** for the motor power cable itself.

According to the individual connection properties, these requirements can be fulfilled with or without the HAS02 accessory.

Connections of the Components in the Drive System

Shield Connection with Accessory HAS02

Using the optional accessory HAS02 with connection over a large surface area directly to the device is the best solution for shield connection. The figure below illustrates this **by the example of HCS02 drive controllers**:

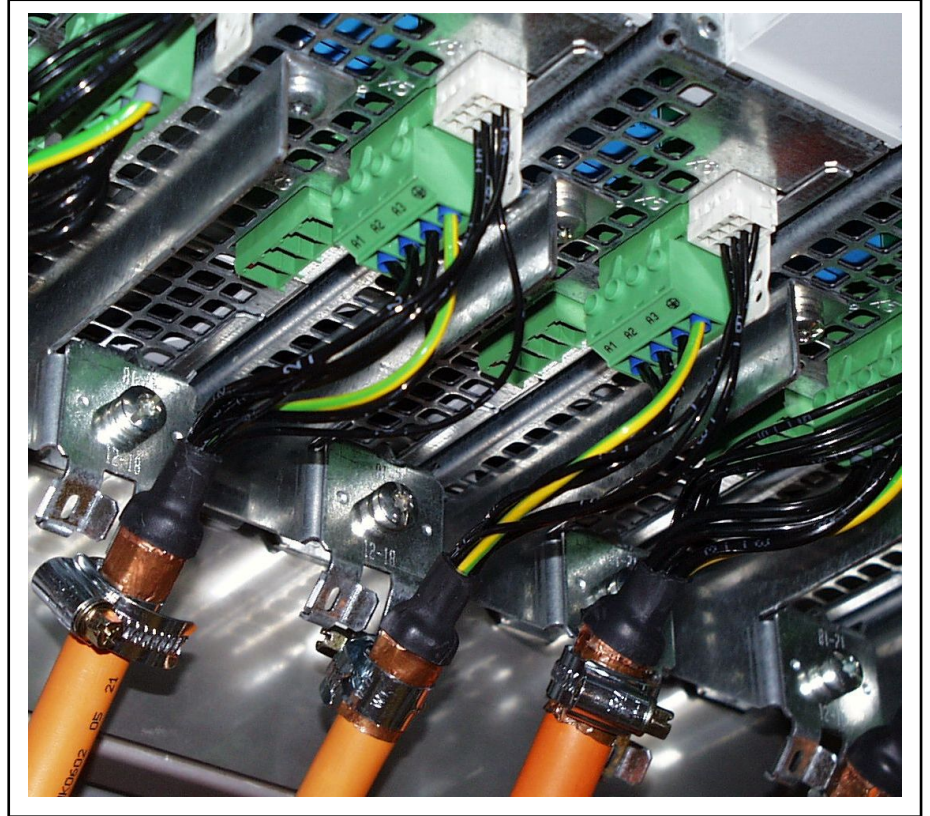



Fig. 13-15: Connecting HAS02 to HCS02

 For information on the available accessory HAS02 and how to mount it, see Project Planning Manual "Rexroth IndraDrive Additional Components and Accessories".

Shield Connection without Accessory HAS02

For shield connection without HAS02 accessory, connect the cable shield with the lowest possible impedance to the drive controller.

The following paragraphs describe two basic alternatives of this kind of connection.

- Alternative 1** Connect cable shield to a ground bus. The maximum distance between ground bus and device connection is 100 mm. For this purpose, take the given length of the single strands at the cable end into account for ready-made Rexroth motor power cables.

Connections of the Components in the Drive System

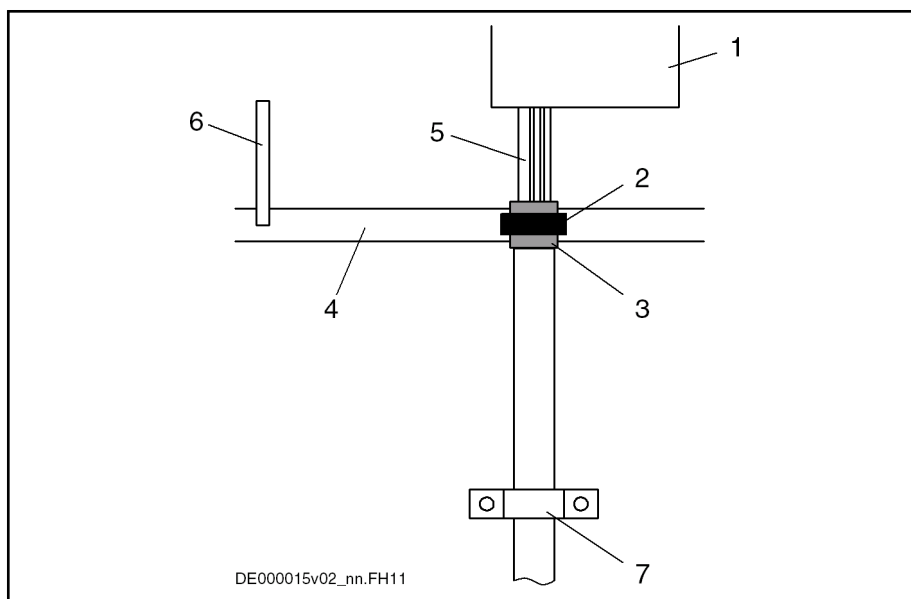

- | | |
|---|--|
| 1 | Drive controller |
| 2 | Clip for shield contact |
| 3 | Overall shield of the motor power cable folded back |
| 4 | Ground bus in control cabinet |
| 5 | Single strands of motor power cable |
| 6 | Connection of ground bus to supplying device |
| 7 | Strain relief (as near as possible to exit point from control cabinet) |

Fig. 13-16: Shield Connection, Alternative 1

- With a clip (2), connect overall shield of motor power cable (3) to ground bus (4). (If you use your own cable, make sure the shields of the two inner pairs of wires are in contact with the overall shield.)
- With a cable (6) (line cross section: at least 10 mm²), connect ground bus (4) to ground connection at supplying device (Rexroth IndraDrive supply unit or Rexroth IndraDrive drive controller HCS).

Alternative 2 Connect cable shield to a ground bus. The cable length between device and ground bus mustn't be more than a maximum of 1 m. For this purpose, prepare the motor cable in accordance with the description below:

Connections of the Components in the Drive System

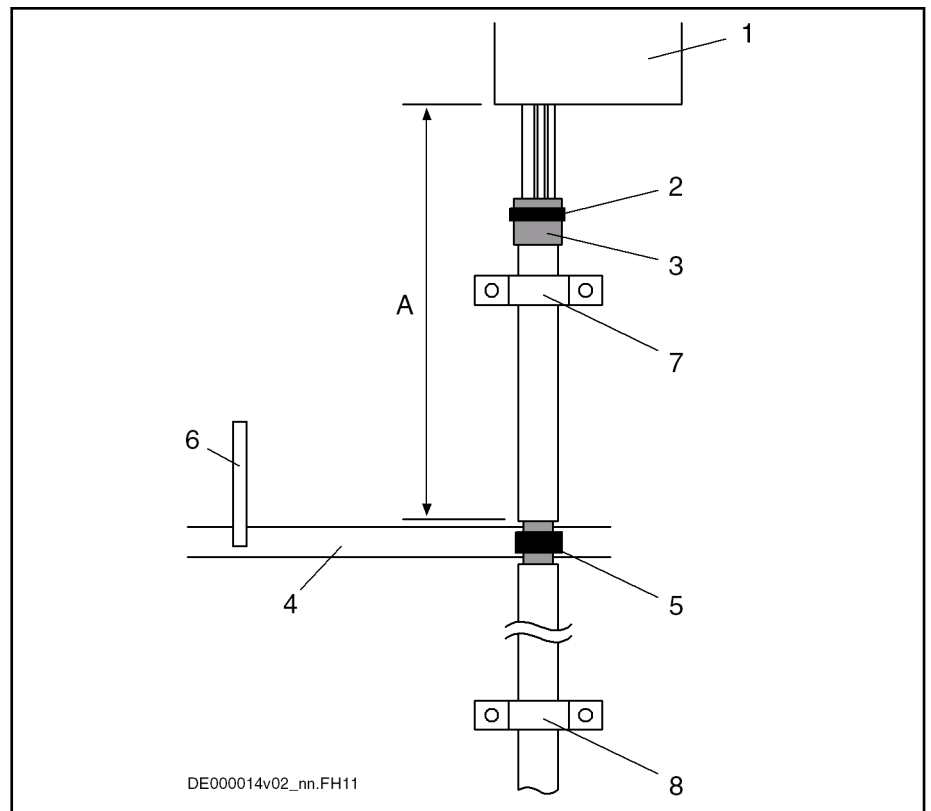

- | | |
|---|---|
| 1 | Drive controller |
| 2 | Cable tie |
| 3 | Overall shield of the motor power cable folded back |
| 4 | Ground bus in control cabinet |
| 5 | Connection between overall shield of motor power cable laying bare and ground bus |
| 6 | Connection of ground bus to supplying device |
| 7 | Strain relief (as near as possible to the drive-side cable end) |
| 8 | Strain relief (as near as possible to exit point from control cabinet) |
| A | Cable length between ground bus and device: < 1 m |

Fig. 13-17: Shield Connection, Alternative 2

- With a cable tie (2), press drive-side cable end in such a way that shields of two inner pairs of wires (motor temperature, holding brake) have good contact with overall shield of motor power cable (3). (If you use your own cable, make sure the shields of the two inner pairs of wires are in contact with the overall shield.)
- On level of ground bus in control cabinet, remove a piece of cable sheath from motor power cable in order to lay bare the overall shield (5).
- Connect overall shield (5) to ground bus in control cabinet with an appropriate connection (clip). The connection must have a cross section of at least 10 mm².
- With a cable (6) (line cross section: at least 10 mm²), connect ground bus (4) to ground connection at supplying device (Rexroth IndraDrive supply unit or Rexroth IndraDrive drive controller HCS).
- Make sure there is sufficient strain relief for motor power cable as near as possible to drive-side cable end (7).
- In addition, make sure there is sufficient strain relief for motor power cable as near as possible to exit point from control cabinet of motor power cable (8).

Connections of the Components in the Drive System



Do not remove the shield of the motor cable between ground bus and device.

If the motor power cables are routed to the control cabinet via flange sockets, directly connect the shield to the wall of the control cabinet over a large surface area via the housing of the flange socket. Make sure there is sufficient separate strain relief.

Bonding Conductor

Bad ground connection between motor housing and control cabinet housing, as well as long motor cables, can require additional routing of a bonding conductor of a cross section of normally 10 mm² between control cabinet housing and motor housing.



For cable lengths of more than 50 m, the cross section should be at least 35 mm².

Shield Connection of Kit Motors

For kit motors, make sure that the connection lines are run in shielded form or under metal between winding and terminal box, if the terminal box is not directly mounted on the spindle case.

Shield Connection of Linear Motors

For linear motors, connect the shield of the connection cable between primary part and terminal box via clips to machine housing or metal shell.

Shielding of Motor Temperature Monitoring and Motor Holding Brake

The inner shields of motor temperature monitor and motor holding brake in the motor cable are connected to the drive controller at one end.

13.2 Overall Connection Diagrams of Drive Systems

Overall connection diagrams of Rexroth IndraDrive systems: See [chapter 9 "Circuits for the Mains Connection"](#) on page 141.

To draw up the overall connection diagrams there are **ePlan macros** of the devices available. Please ask our sales representative.

14 Third-Party Motors at Rexroth IndraDrive Controllers

14.1 General Information on Third-Party Motors

14.1.1 Why Use Third-Party Motors at Rexroth IndraDrive Controllers?

Today, machine axes are mainly moved with electric drives. Motors of standard design are used in most cases, as this is the most cost-efficient solution.

Special Requirements

Due to special requirements at machine axes, constructional or safety-related aspects, it may be necessary for the machine manufacturer to use a motor construction diverging from the standard.

Motor Designs not Included in Product Range

For these cases, there is the demand on drive suppliers to realize drives with motors that are not included in their own product ranges due to the special design.

Check Before Using Third-Party Motors

At drive controllers of the Rexroth IndraDrive range, it is possible to use third-party motors. For this purpose, check whether the third-party motor complies with the requirements of use.

The Functional Description of the firmware contains forms for motor data. Procure the completed forms for the performance test of a third-party motor.

14.1.2 Which are the Important Directives?

In accordance with the legal regulations (EU Directive EMC 89/336/EEC and the German EMC laws), installations and machines must be designed and built in accordance with the present state-of-the-art of standardization.

In order to comply with the machine directives regarding "electromagnetic compatibility (EMC)", a conformity test of the drive system (motor with controller and connection design) must be carried out. The machine manufacturer must guarantee the test of the drive system and compliance with the directives.

14.1.3 Third-Party Motors to be Controlled

Motor Types

The following motor types can be controlled:

- Asynchronous motors, rotary
- Asynchronous motors, linear
- Synchronous motors, rotary
- Synchronous motors, linear

These motors can be operated within the scope of the technical data of the selected Rexroth IndraDrive controller. If motors have been provided with a holding brake, it should be controlled via the drive controller. Make sure that the relevant technical data of the motor holding brake are complying with those of the holding brake output!



For third-party motors Rexroth, as a matter of principle, does not assume the guarantee for the power data at the motor shaft!

Synchronous Motors

For synchronous motors, the commutation offset must be set during commissioning. The drive firmware provides several methods for determining this offset so that it is possible to determine the value for different motor characteristics.

Third-Party Motors at Rexroth IndraDrive Controllers



Observe the restrictions in conjunction with the commutation offset determination when using synchronous motors! See firmware documentation, chapter "Drive Control", "Commutation Setting".

Possibly available reluctance property cannot be used for synchronous third-party motors! For third-party motors, it is impossible to determine fail-safe motor parameter values for using the reluctance property. The respective bit of "P-0-4014, Type of construction of motor" therefore mustn't be set!

14.2 Requirements on Third-Party Motors

14.2.1 General Information

For successful and fail-safe use of a third-party motor, check

- whether the third-party motor to be controlled satisfies the voltage loads
- which controller, including supply, is suitable due to the motor power to be delivered
- whether the third-party motor has the required minimum inductance
- whether the motor can be protected against inadmissible temperature rise in the case of overload (temperature evaluation)
- whether the mounted position measuring system can be evaluated by the drive controller or which position measuring system can be selected for kit motors

14.2.2 Voltage Load of the Third-Party Motor

The voltage load of the insulation system of a motor occurring in practical application is mainly influenced by the following characteristics:

- The output variables of the drive controller which is used (feed the transmission distance)
- Cable parameters depending on cable design and length (determine the properties of the transmission distance, such as the attenuation)
- The motor design regarding capacitive and inductive properties (form the end of the transmission distance)

As a result of the variables, the insulation system of the third-party motor, as regards voltage, is loaded by the following values:

- Peak voltage U_{pp} and
- Voltage change dv/dt

The occurring peak voltages at the motor are caused by reflections in the motor cable. The insulation of the motor is thereby loaded with other peak voltages and voltage changes than the ones occurring at the output of the power section.



Determine the occurring voltage load at the **terminals** of the third-party motor in the application with all involved components.

Using the HMF Motor Filter

Use voltage-reducing components (e.g. motor filter HMF), if one of the following criteria applies:

- Allowed voltage change (dv/dt) of third-party motor: **< 5 kV/μs**
- Allowed peak voltage (crest value) of third-party motor between phase-phase and phase-housing: **< 1,500 V**

Third-Party Motors at Rexroth IndraDrive Controllers

- Both values (voltage change, peak voltage) are influenced by:
 - **DC bus voltage:**
The higher the DC bus voltage at which the drive system is operated, the higher the value of the voltage change and the occurring peak voltage.
 - **Length and electrical properties of the motor cable:**
The shorter the motor cable, the less the attenuation effects.
The longer the motor cable, the higher the degree of voltage overshoot at the motor-side cable end.
 - For a motor cable length $l < 25 \text{ m}$ and mains voltage $U_{N3} > \text{AC } 440 \text{ V}$, it is recommended that you use voltage-reducing components.



Apart from the nominal current I_N , especially take the maximum allowed switching frequency of the power output stage (f_s) into account with which the motor filter HMF may be operated.

Verify the success of the voltage-reducing measures.

14.2.3 Minimum Inductance of Third-Party Motor

Depending on the drive controller used, the motor has to have a minimum value for inductance. The actually available inductance of a motor can be measured directly between two motor terminals by means of an inductance measuring bridge. The measurement has to be made for a complete motor wired for normal operation but not yet connected. During the measurement, one motor terminal remains open! For asynchronous motors, the measured value can only be used if the rotor doesn't have closed slots!

Drive controller	Minimum required motor inductance
HCS at 3 × AC 230 V	$L_{U-V} = 60 \times 4 / (\sqrt{2} \times I_{Typ} \times f_s)$ (in mH)
HMS, HMD at HMV (3 × AC 400 V) HMS, HMD at HCS (3 × AC 400 V) HCS at 3 × AC 400 V	$L_{U-V} = 80 \times 4 / (\sqrt{2} \times I_{Typ} \times f_s)$ (in mH)
HMS, HMD at HMV (3 × AC 480 V) HMS, HMD at HCS (3 × AC 480 V) HCS at 3 × AC 480 V	$L_{U-V} = 116 \times 4 / (\sqrt{2} \times I_{Typ} \times f_s)$ (in mH)

I_{Typ} Maximum current of drive controller according to type code (rms value)

f_s Desired switching frequency in kHz

Tab. 14-1: Minimum Inductances Depending on Drive Controller Data, Supply Units and Supply Voltage

Install a three-phase choke in the motor feed wire, if the inductance of the third-party motor is smaller than indicated in the table above. This choke has to increase the inductance that can be measured between two motor terminals to the minimum value.

Third-Party Motors at Rexroth IndraDrive Controllers



When the inductance is measured, different inductance values can be determined at different rotor positions within one pole pair distance of the motor. The average value is relevant for the check of the minimum value.

Correct values can only be determined when the motor is **in standstill!**

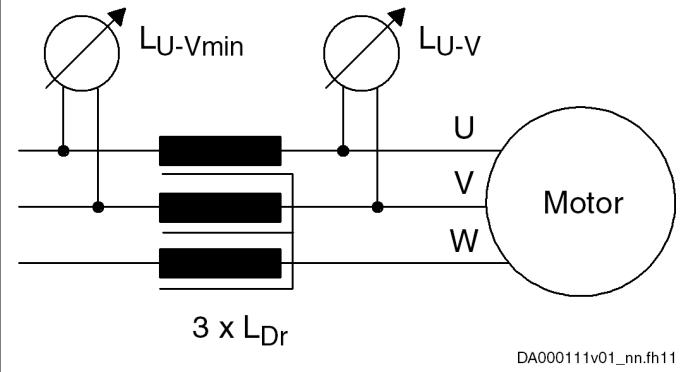
Available third-party motor	Planned third-party motor
 <p style="text-align: center;">$3 \times L_{Dr}$</p> <p style="text-align: right; font-size: small;">DA000111v01_nn.fh11</p>	<p>Calculate the leakage inductance (asynchronous motor) or inductance (synchronous motor) of the third-party motor by means of the single-phase equivalent circuit diagram (manufacturer's specification!).</p> <p>Determine choke by means of calculation, if necessary.</p> <p>It is recommended that you contact Rexroth!</p>
<p>$L_{Dr} = 0.5 \times (L_{U-Vmin} - L_{U-V})$ (inductance measurement with 1 kHz)</p> <p><i>Fig. 14-1: Mounting of $3 \times L_{Dr}$ (Three-Phase Choke)</i></p>	
<p>Requirements on the choke:</p> <ul style="list-style-type: none"> • $I_{n_Dr} \geq I_{n_Mot}$ The rated current of the choke has to be greater than or equal to the rated motor current. • Depending on the maximum speed, the choke is loaded with the respective output frequency and the PWM frequency of the drive controller. • The insulation class has to correspond at least to that of the motor or has to be sized for higher temperatures. • The voltage load of the choke depends on the drive controller used. 	

Tab. 14-2: Data for Possibly Required Choke

14.2.4 Temperature Evaluation of Third-Party Motor

Only operate such motors with incorporated temperature sensor at Rexroth IndraDrive controllers so that the motor can be thermally monitored by the drive controller and protected against destruction by too high temperature rise (see "P-0-0512, Temperature sensor").

When, in exceptional cases, you would like to operate third-party motors without temperature sensor at Rexroth IndraDrive controllers, you must determine the thermal time constants of motor housing (P-0-4035) and motor winding (P-0-4034, P-0-4037). By means of its temperature model, the firmware can correctly reflect the cooling situation of the motor.



In case the motor housing or fan is dirty, this worsens the cooling situation of the motor and protection against thermal overload is therefore insufficient!

14.3 Requirements on the Encoder of the Third-Party Motor

14.3.1 Motor Encoder of Asynchronous Third-Party Motor

Asynchronous motors can also be controlled by Rexroth IndraDrive controllers in "open-loop" operation (without motor encoder). In "closed-loop" operation (with motor encoder), a relative measuring system is sufficient for asynchronous motors.

14.3.2 Motor Encoder of Synchronous Third-Party Motor

For fail-safe drives with synchronous third-party motors at Rexroth IndraDrive controllers, the following possible combinations or restrictions have to be taken into account when selecting the measuring system:

Drive range	Motor measuring system	Synchronous third-party motor
Rexroth IndraDrive	Absolute	■
	Relative	□

- Advantageous combination
- Combination is possible (restrictions specific to application), commissioning may be more complicated!

Tab. 14-3: Possible Combinations of Synchronous Third-Party Motor and Motor Measuring System



The control section integrated in the drive controller can evaluate measuring systems as a motor encoder, if they are contained in "P-0-0074, Encoder type 1 (motor encoder)" (see also Project Planning Manual "Rexroth IndraDrive Drive Controllers Control Sections").

For information on absolute and relative measuring systems, see section "Measuring Systems" of firmware documentation!

14.3.3 Motor Encoder Resolver - Notes on Selection

For operating "resolver" encoder types, there is the optional module EN1 available (see also Project Planning Manual "Rexroth IndraDrive Drive Controllers Control Sections").

Observe:

- Data of resolver system to be compared must be available at 4 kHz
- Ratio
- Current consumption
- DC resistance of stator
- Number of poles
- Phase shift

You can get more detailed information on request.

14.4 Notes on Selection and Commissioning

14.4.1 Selecting the Controller as Regards Continuous Current

The drive controller required for the respective motor and the supply unit are determined by comparing the motor data to the data of these devices (see

Third-Party Motors at Rexroth IndraDrive Controllers

Project Planning Manual "Rexroth IndraDrive Supply Units and Power Sections").



The continuous current of the drive controller should be greater than the one of the motor. The continuous power of the supply must be greater than the sum of all average powers of the axes of the drive system!

14.4.2 Selecting the Connection Technique

For the available power cables and encoder cables, see documentation "Rexroth Connection Cables".

14.4.3 Notes on Commissioning



For further information, notes on commissioning and supporting documents (e.g., forms for entering the required data) see firmware documentation.

15 Calculations

15.1 Determining the Appropriate Drive Controller

15.1.1 Introduction

Supply for the drive system Rexroth IndraDrive takes place by means of compact HCS converters or HMV supply units. According to the drive task, design of drive controller and operating conditions, chokes, additional capacitors, braking resistors, transformers, etc., may be required.

The drive controller or supply unit has to supply the DC bus continuous power and for acceleration the DC bus peak power. With regenerative operation, they must be able to absorb the continuous recovery power and peak recovery power.

Before the drive controller or supply unit and the additional components can be selected, the motors and drive controllers to be used must be defined.

To ensure correct sizing of the drive system, you should do the calculations in the order described in the following chapters.

15.1.2 DC Bus Continuous Power

The DC bus continuous power is calculated from the mechanical power, taking the following aspects into consideration:

- Motor and controller efficiency
- Simultaneity Factors

Mechanical Power

$$P_m[W] = M \times \omega = \frac{M \times n \times 2\pi}{60}$$

$$P_m[kW] = \frac{M \times n}{9550}$$

P_m Mechanical power
 M Torque [Nm]
 ω Angular velocity [min^{-1}]
 n Motor speed [min^{-1}]

Fig. 15-1: Mechanical Power

Mechanical Continuous Power for Servo Drives

To calculate the mechanical continuous power of a servo drive, you need the effective motor torque and the average motor speed.

The effective motor torque can be taken from the servo drive calculation. The average motor speed is determined as follows:

Average Motor Speed

For servo drive tasks at common NC machine tools, the average motor speed is approx. 25% of the rapid traverse speed. In some cases, however, this rough estimation is not sufficient. An exact calculation of the average motor speed is required.

Average Speed With Run-Up and Braking Times not Taken Into Account

If the period during which the motor is run at constant speed is significantly greater than the run-up and braking time, the following applies:

Calculations

$$n_{av} = \frac{n_1 \times t_1 + n_2 \times t_2 \dots + n_n \times t_n}{t_1 + t_2 \dots + t_n}$$

n_{av} Average motor speed [min^{-1}]

$n_1 \dots n_n$ Motor speed [min^{-1}]

$t_1 \dots t_n$ Duty cycle [s]

Fig. 15-2: Average Speed; Effects of Run-Up and Braking Times not Taken Into Account

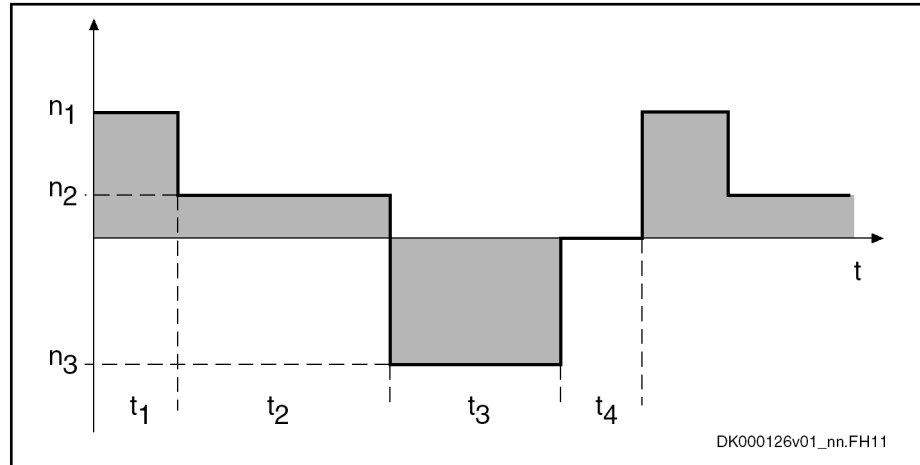

Fig. 15-3: Speed Characteristic; Effects of Run-Up and Braking Times not Taken Into Account

In dynamic applications with short cycle times, e.g. roll feeds and nibbling machines, run-up and braking times must be taken into account.

NOTICE**Damage to the drive controller!**

- The DC bus capacitors in the drive controller have been dimensioned for loading with continuous power.
- If loaded with cyclic charging and discharging processes of high energy content, the DC bus capacitors can be overloaded, especially with decreasing mains connection voltage.

Operate additional capacitors at the DC bus.

Average Speed With Run-Up and Braking Times Taken Into Account

$$n_{av} = \frac{\frac{n}{2} \times t_H + n \times t_1 + \frac{n}{2} \times t_B}{t_H + t_1 + t_B + t_2}$$

n_{av} Average motor speed [min^{-1}]

n Motor speed [min^{-1}]

t Time [s]

t_H Run-up time [s]

t_B Braking time [s]

Fig. 15-4: Average Speed; Effects of Run-Up and Braking Times Taken Into Account

Calculations

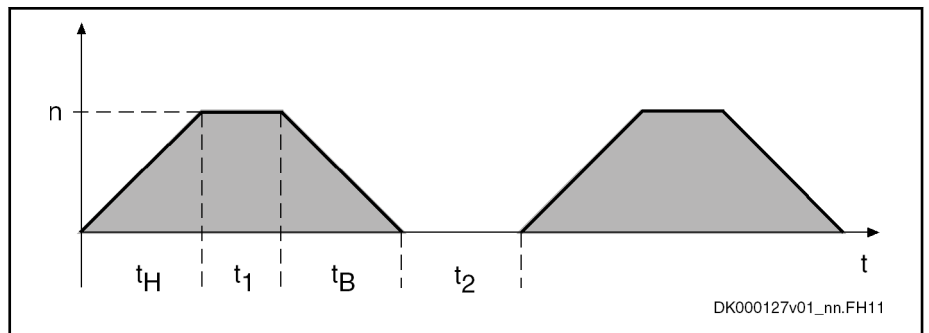

Fig. 15-5: Average Speed; Effects of Run-Up and Braking Times Taken Into Account

Mechanical Power for Servo Drives

$$P_{mSe} = \frac{M_{eff} \times n_{av}}{9550}$$

P_{mSe} Mechanical continuous power for servo drives [kW]

M_{rms} Effective motor torque [Nm]

n_{av} Average motor speed [min^{-1}]

Fig. 15-6: Mechanical Power for Servo Drives

Mechanical Power for Main Drives

Main drives are drives which are mainly used in the constant power speed range. Thus, nominal power is decisive for sizing the mains supply. The mechanical nominal power of the main drives can be taken from the operating characteristic or calculated from nominal speed and nominal torque.

$$P_{mHa} = \frac{M_n \times n_n}{9550}$$

P_{mHa} Mechanical nominal power for main drives (shaft output) [kW]

M_n Nominal motor torque [Nm]

n_n Nominal motor speed [min^{-1}]

Fig. 15-7: Mechanical Power for Main Drives

DC Bus Continuous Power for Servo Drives

The drive controller or the group of drive controllers has to make available the DC bus power. However, in most applications, simultaneous loading of all drives will not occur; thus, only the simultaneously occurring power must be considered for calculating the DC bus continuous power to be made available for servo drives. To calculate the DC bus continuous power to be made available for typical NC feed axes at machine tools, inclusion of a so-called simultaneity factor has proved to be favorable in practical application:

Number of axes	1	2	3	4	5	6	7	$n = n + 1$
Simultaneity factor (F_G)	1	1,15	1,32	1,75	2,0	2,25	$F_G=2,5$	$F_{Gn} = F_G + 0,25$

Tab. 15-1: Simultaneity Factors

Calculations

$$P_{ZWDSe} = \frac{(P_{mSe1} + P_{mSe2} \dots + P_{mSen}) \times 1,25}{F_G}$$

P_{ZWDSe}	DC bus continuous power for servo drives [kW]
$P_{mSe1} \dots$	Mechanical continuous power for servo drives [kW]
P_{mSen}	
F_G	Simultaneity factor
1,25	Constant for motor and controller efficiency
<i>Fig. 15-8:</i>	<i>DC Bus Continuous Power for Servo Drives</i>

DC Bus Continuous Power for Main Drives

If several main drives are operated at one DC bus, the simultaneously required DC bus continuous powers must be added:

$$P_{ZWHa} (P_{mHa1} + P_{mHa2} \dots + P_{mHan}) \times 1,25$$

P_{ZWHa}	DC bus continuous power for main drives [kW]
$P_{mHa1} \dots$	Mechanical continuous power for main drives [kW]
P_{mHan}	
1,25	Constant for motor and controller efficiency
<i>Fig. 15-9:</i>	<i>DC Bus Continuous Power for Main Drives</i>

Chokes and additional capacitors have to be selected in accordance with the actually required DC bus continuous power. It is determined by the nominal power of the main drives.



When selecting the drive controllers, make sure that their maximum DC bus continuous power will not restrict the short-time operation power of the main drives.

DC Bus Continuous Power for Main and Servo Drives

When main and servo drives are operated at a drive controller, the required DC bus continuous powers must be added.

At a typical NC machine tool, the required DC bus continuous power will be primarily defined by the main drive. Accordingly, the following equation is to be used for such applications:

$$P_{ZWD} = [P_{mHa} + 0,3 \times (P_{mSe1} + P_{mSe2} \dots + P_{mSen})] \times 1,25$$

0,3	Empirical value for standard machine tools
1,25	Constant for motor and controller efficiency
P_{ZWD}	DC bus continuous power [kW]
$P_{mSe1} \dots$	Mechanical continuous power for servo drives [kW]
P_{mSen}	
P_{mHa}	Nominal power for main drive (shaft output) [kW]
<i>Fig. 15-10:</i>	<i>DC Bus Continuous Power for Main and Servo Drives at NC Machine Tools</i>

$$\sum P_{ZWD, Anlage} \leq \sum P_{ZWD, Geräte}$$

$P_{ZWD, Anlage}$	Generated DC bus continuous power of the installation
$P_{ZWD, Geräte}$	Allowed DC bus continuous power of the devices
<i>Fig. 15-11:</i>	<i>Supply Condition: DC Bus Continuous Power</i>

15.1.3 DC Bus Peak Power

The drive controller or combination of drive controllers has to produce DC bus peak power for example when several axes of a machine tool simultaneously accelerate to rapid traverse rate after a tool change, approaching the workpiece.

NOTICE

Damage due to supply unit overload!

To avoid damage to the drive controller, the sum of peak powers of all drives mustn't exceed the DC bus peak power of the supplying drive controller (central supply).

$$P_{ZWS} = \frac{(M_{NC} \pm M_G) \times n_{eil} \times 1,25}{9550}$$

M_{NC}	Acceleration torque in the drive [Nm]
M_G	Torque due to weight for vertical axes [Nm]
n_{eil}	Speed at rapid traverse rate [min ⁻¹]
P_{ZWS}	DC bus peak power [kW]
1,25	Constant for motor and controller efficiency
Fig. 15-12:	DC Bus Peak Power per Drive

$$\sum P_{ZWS, Anlage} \leq \sum P_{ZWS, Geräte}$$

$P_{ZWS, Anlage}$	Generated DC bus peak power of the installation
$P_{ZWS, Geräte}$	Allowed DC bus peak power of the devices
Fig. 15-13:	Supply Condition: DC Bus Peak Power

15.1.4 Regenerative Power

When all main and servo drives connected to a drive controller or combination of drive controllers brake simultaneously, the generated regenerative power must not be greater than the maximum regenerative power of the drive controller or combination of drive controllers. If this is not taken into consideration in sizing the system, thermal destruction of the braking resistors in the drive controllers may occur.

NOTICE

Destruction due to braking resistor overload!

Do the project planning for drive controllers or combinations of drive controllers in such a way that the resulting regenerative power can be absorbed when all main and servo drives connected to the drive controller or combination of drive controllers brake simultaneously.

$$W_{rot} = \frac{J_G}{2} \times \left(n_{eil} \times \frac{2p}{60} \right)^2$$

W_{rot}	Rotary energy [Ws]
n_{eil}	Speed at rapid traverse rate [min ⁻¹]
J_G	Motor inertia and load inertia reduced to the motor shaft [kgm ²]
Fig. 15-14:	Regenerative Power per Drive

Calculations

$$\sum W_{R, Anlage} \leq \sum W_{R, Geräte}$$

$W_{R, Anlage}$ Generated regenerative power of the installation

$W_{R, Geräte}$ Allowed regenerative power of the devices

Fig. 15-15: Supply Condition: Regenerative Power



Influence of efficiency

The energy absorption occurring in the steady-state condition in the majority of cases is less than the calculated energy absorption, because all involved components (such as load, gear, motor, cables) absorb a part of the regenerative power.

Only reduce the generated regenerative power when the efficiency behavior is known.

Energy Absorption of Braking Resistor

Within the minimum cycle time T_{cycl} , the braking resistor dissipates the electrically absorbed energy to its environment as heat. The braking resistor makes available the energy absorption during its duty cycle. The energy absorption is calculated as follows:

$$W_R = t_{on} \times P_{BS}$$

$$W_R = P_{BD} \times (T_{cycl} - t_{on})$$

W_R Absorbed regenerative power

t_{on} Allowed duty cycle

P_{BS} Allowed peak power of braking resistor

P_{BD} Allowed continuous power of braking resistor

T_{cycl} Allowed cycle time

Fig. 15-16: Energy Absorption of Braking Resistor



Energy absorption capacity with long cycle times

For cycles with " $T > 5 \times T_{cycl}$ ", the indicated maximum regenerative power to be absorbed $W_{R,max}$ can be used.



Several braking resistors (e.g. HLR) at common DC bus

With several braking resistors at the DC bus, the available energy absorption is determined as the sum of the individual energy absorptions. For this purpose, the same switch-on threshold must take effect for all involved braking resistors.



Adjustment of switch-on threshold!

For the adjustment of the switch-on threshold, see also the following parameters:

- P-0-0833, Braking resistor threshold
- P-0-0858, Data of external braking resistor

15.1.5 Reduction of Generated Power Dissipation - Additional External Capacitors at DC Bus

When the drive brakes, the rotary energy present in the mechanical system is released as regenerative power in the DC bus of the drive controller or group of drive controllers. It can

Calculations

- be converted into dissipation heat via the braking resistor integrated in the drive controller or the additional braking resistor

or

- be stored as energy in the drive controllers and possibly available additional capacitors and reused for following acceleration processes. This reduces the power dissipation generated in the control cabinet and lowers the energy consumption.

The following applies to successful use of additional capacitors to avoid unnecessary power dissipation in the control cabinet:

$$\sum W_{R, Anlage} \leq \sum W_{ZW, Geräte}$$

$W_{R, Anlage}$ Generated regenerative power of the installation

$W_{ZW, Geräte}$ Storable energy of the DC bus capacitors

Fig. 15-17: Condition to Avoid Power Dissipation From the Regenerative Power

Additional Capacitors as Energy Stores

Many acceleration and deceleration processes are typical for applications with servo drives (e.g. nibbling machines or roll feeds). This is why it can be useful for such applications to connect additional capacitors to the DC bus of the drive controllers. This provides the following advantages:

- For drive controllers without mains regeneration function, this prevents the braking resistor in the drive controller from being switched on when the drives brake. The dissipation heat in the control cabinet is considerably reduced.
- The energy stored in the DC bus capacitors can be used for acceleration. The energy demand of the installation is reduced.

Storable Energy in DC Bus

The specific energy absorption capacity of the drive controllers can be determined with the formula below.

$$W_{DC} = \frac{(C_{DC} + C_{DCext})}{2} \times (U_{R_DC_On}^2 - U_{DC}^2)$$

W_{DC} Storable energy in DC bus

C_{DC} DC bus capacitance in device [F]

C_{DCext} External DC bus capacitance [F]

$U_{R_DC_On}$ Braking resistor switch-on threshold

U_{DC} DC bus voltage

Fig. 15-18: Storable Energy in DC Bus

The additional capacitor has to be sized in such a way that it can store the rotary drive energy:

$$C_{DCext} \geq \frac{2W_{rot}}{(U_{R_DC_On}^2 - U_{DC}^2)} - C_{DC}$$

$U_{R_DC_On}$ Braking resistor switch-on threshold

U_{DC} DC bus voltage

W_{rot} Rotary energy [Ws]

C_{DC} Internal capacitance [F]

C_{DCext} Required external DC bus capacitance [F]

Fig. 15-19: Required Additional Capacitance [F]

Calculations

NOTICE

Property damage caused by overload of HMV and HCS devices!

Comply with maximum allowed external DC bus capacitances! See electrical data of the HMV and HCS components.

NOTICE

Property damage caused by overload of the additional external capacitors!

- Only use allowed components.
- The properties of the additional capacitors have to comply with minimum requirements:
 - Min. **dielectric strength**: DC 900 V
 - Max. **discharge time**: 30 min
 - Take measures against fire in the case of overload, e.g. by **housing** the capacitors.
- **Connect correct polarity**: Connect L+ to positive pole and L- to negative pole of the additional capacitors.



- For additional external capacitors, observe that the series connection of these units can require a balancing device.
- Size additional capacitors at the DC bus for 10% overvoltage at the mains connection.
- As the supply voltage increases the storable energy in the DC bus decreases, because the differential voltage between braking resistor switch-on threshold U_B and DC bus voltage U_{ZW} (crest value of supply voltage) is reduced.
- Take the service life of external capacitors into account.

The figure below illustrates the characteristic of the storable energy in the DC bus versus mains voltage with fixed braking resistor switch-on threshold U_B by the example of HCS02.1E devices.

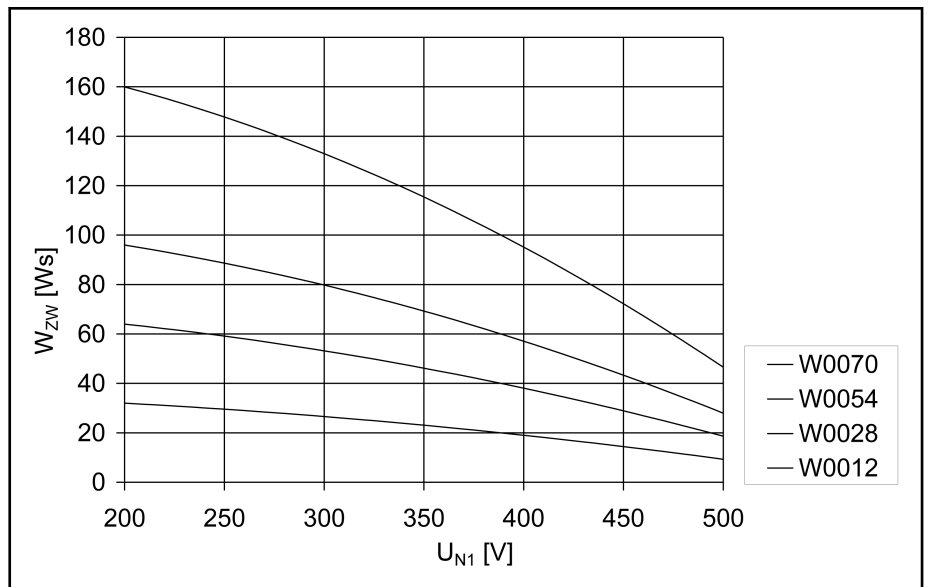

Fig. 15-20: Storable Energy in DC Bus

15.1.6 Continuous Regenerative Power



In terms of average period of time, the sum of the continuous regenerative power of all drives mustn't exceed the allowed continuous power of the regenerative device (regeneration of supply units or braking resistors of converters).

In applications with servo drives at typical NC machine tools, machining time is relatively long relative to the cycle time. Accordingly, the continuous regenerative powers are small. For this type of applications, exact calculation is not required. It is sufficient to make sure that the regenerative peak power is not exceeded.

Exact calculation is required, for example, for one of the following applications:

- Applications with servo drives which are characterized by many acceleration and deceleration processes (e.g. nibbling machines or roll feeds)
- Machine tools with modular main drive
- Applications which involve lowering of large masses, e.g. loading bridges, warehousing and transport systems

Before the continuous regenerative power can be calculated, the rotary energy of the drives and the potential energy of non-balanced masses must be calculated.

$$W_{rot} = \frac{J_g}{2} \times \left(n_{eil} \times \frac{2\pi}{60} \right)^2 \times z$$

W_{rot}	Rotary energy [Ws]
n_{eil}	Speed at rapid traverse rate [min ⁻¹]
J_g	Inertia (motor + load) [kgm ²]
z	Number of braking processes per cycle

Fig. 15-21: Rotary Energy of the Drives

Calculations

$$W_{pot} = m \times g \times h \times z$$

W_{pot}	Potential energy [Ws]
m	Load mass [kg]
g	Gravitational acceleration = 9.81 m/s ²
h	Lowering height [m]
z	Number of lowering processes per cycle

Fig. 15-22: Potential Energy of Non-Balanced Masses

$$P_{RD,Anlage} = \frac{W_{pot} + W_{rotg}}{t_z}$$

$$\sum P_{RD,Anlage} \leq \sum P_{BD,Geräte}$$

$P_{RD,Anlage}$	Generated continuous regenerative power [kW]
$P_{BD,Geräte}$	Allowed braking resistor continuous power [kW]
t_z	Cycle time [s]
W_{potg}	Sum of potential energies [kWs]
W_{rotg}	Sum of rotary energies [kWs]

Fig. 15-23: Continuous Regenerative Power

**Influence of efficiency**

The continuous regenerative power occurring in the steady-state condition in the majority of cases is less than the calculated energy absorption, because all involved components (such as load, gear, motor, cables) absorb a part of the regenerative energy.

Only reduce the generated continuous regenerative power when the efficiency behavior is known.

Continuous Power of Braking Resistor

Continuous power of the braking resistor:

$$P_{BD} = \frac{t_{on} \times P_{BS}}{T_{cycl}}$$

P_{BD}	Allowed continuous power of braking resistor
t_{on}	Allowed duty cycle
P_{BS}	Allowed peak power of braking resistor
T_{cycl}	Allowed cycle time

Fig. 15-24: Braking Resistor Continuous Power

**Several braking resistors (e.g. HLR) at common DC bus**

With several braking resistors at the DC bus, the available continuous power is less than the sum of the individual continuous powers.

Relative Duty Cycle of Braking Resistor

$$\sum P_{BD} = f \times (P_{BD_1} + P_{BD_2} + \dots + P_{BD_n})$$

P_{BD_1} , Data sheet data of the braking resistors

P_{BD_2} , P_{BD_n}

f Balancing factor for PDB ($f = 0.8$ (guide value)); see also technical data of converter and supply unit)

Fig. 15-25: Sum of Braking Resistor Continuous Powers

The quotient of t_{on} and T_{cycl} is understood by the duty cycle ED. The maximum allowed relative duty cycle ED_{max} is calculated from the nominal data for HLR braking resistors:

$$ED_{max} = \frac{t_{on}}{T_{cycl}}$$

ED_{max} Maximum allowed relative duty cycle

t_{on} Allowed duty cycle

T_{cycl} Allowed cycle time

Fig. 15-26: Relative Duty Cycle of Braking Resistor



Braking times

Within the indicated minimum cycle time T_{cycl} , the braking resistor may be switched on, as a maximum, for the time t_{on} .

15.1.7 Peak Regenerative Power

Usually, peak regenerative power will occur when an E-Stop signal is triggered and all axes brake simultaneously.

NOTICE Risk of damage due to extended braking times and distances!

Select the supply unit such that the sum of peak regenerative powers of all drives does not exceed braking resistor peak power of the supply unit.

See the respective motor selection data for the peak regenerative powers.

Peak regenerative power can be roughly calculated by the following equation:

$$P_{RS} = \frac{M_{max} \times n_{max}}{9550 \times 1,25}$$

$$\sum P_{RS, Anlage} \leq \sum P_{RS, Ger\ddot{a}te}$$

$P_{RS,Anlage}$ Generated peak regenerated power [kW]

$P_{RS,Ger\ddot{a}te}$ Allowed braking resistor peak power [kW]

M_{max} Maximum drive torque [Nm]

n_{max} Maximum NC useful speed [min⁻¹]

1,25 Constant for motor and controller efficiency

Fig. 15-27: Peak Regenerative Power

Calculations

Peak Power of Braking Resistor

The braking resistor makes available the peak power during its duty cycle. The peak power is calculated as follows:

$$P_{BS} = \frac{U_{R_DC_on}^2}{R_{DC_bleeder}}$$

P_{BS} Effective peak power

$U_{R_DC_on}$ Switch-on threshold

$R_{DC_bleeder}$

Fig. 15-28: Braking Resistor Peak Power

**Several braking resistors (e.g. HLR) at common DC bus**

With several braking resistors at the DC bus, the available peak power is determined as the sum of the individual peak powers. For this purpose, the same switch-on threshold must take effect for all involved braking resistors.

**Adjustment of switch-on threshold!**

For the adjustment of the switch-on threshold, see also the following parameters:

- P-0-0833, Braking resistor threshold
- P-0-0858, Data of external braking resistor

15.1.8 Calculating the Control Factor

The control factor of an inverter is the ratio of its output voltage to a reference output voltage.

The reference output voltage is the output voltage of the inverter at mains input voltage without overload.

$$\alpha = \frac{U_{out}}{U_{out_ref}} = \frac{U_{out}}{U_{LN}}$$

U_{out} Output voltage of inverter

U_{out_ref} Reference output voltage

U_{LN} Mains voltage

Fig. 15-29: Control Factor

Calculating U_{out} :

$$U_{out} = K_{EMK_1000} \times \frac{rpm}{1000}$$

U_{out} Output voltage of inverter

K_{EMK_1000} Voltage constant [V/min⁻¹]

rpm Speed

Fig. 15-30:

If several inverters have effect on one supply unit at the same time, you have to consider the so-called mean control factor scaled with the axis power.

Calculations

$$\bar{a} = \frac{1}{n \times P_{ZWD}} \times \sum_{i=1}^n (a_i \times P_{mi} \times 1,25)$$

n	Number of inverters
a_i	Several control factors
P_{ZWD}	DC bus continuous power [kW]
P_{mi}	Mechanical continuous power [kW]
<i>Fig. 15-31:</i>	<i>Mean, Scaled Control Factor</i>

When the control factor falls below the given value (see data P_{DC_cont} in the technical data of the corresponding supply unit), additional wattless power occurs. The additional wattless power can be compensated with additional capacitors in the DC bus. The required additional capacitance can be approximately calculated with the following formula.

Applies to $a \leq a_0$!

$$C_{DC_ext} = (a_0 - \bar{a}) \times P_{DC_nenn} \times k_a$$

C_{DC_ext}	Required additional capacitance in DC bus in μF
a_0	Minimum required control factor
a	Calculated mean control factor
P_{DC_nenn}	Nominal power of supply unit [kW]
k_a	200 (preliminary); factor capacitance [μF] / nominal power [kW]
<i>Fig. 15-32:</i>	<i>Required Additional Capacitances When Control Factor Falls Below Minimum Value</i>

Calculations

15.2 Calculations for the Mains Connection

15.2.1 Calculating the Mains-Side Phase Current

The mains-side phase current is required for the following cases:

- Selecting mains contactor
- Determining fuses in the mains connection
- Determining line cross section
- Selecting other components in the mains connection (mains filter, mains choke)

Operation Under Rated Conditions

For data on mains contactor, fuses and cross section in operation under rated conditions, see technical data of the respective component.

Operation at Partial Load

Operation at partial load can lead to smaller mains contactors, fuses and line cross sections.

If defined data for operation at partial load are available, the mains-side phase current can be determined as follows:

1. Determine **motor power**

Take power of drive controller-motor combination from Rexroth Indra-Size or calculate it.

$$P_{mHa} = \frac{M_n \times n_n}{9550}$$

P_{mHa} Mechanical nominal power for main drives (shaft output) [kW]

M_n Nominal motor torque [Nm]

n_n Nominal motor speed [min⁻¹]

2. Determine **DC bus power** from motor power and efficiency

$$P_{DC} = \frac{M_{eff} \times n_m \times 2\pi}{60} \times k$$

P_{DC} Required DC bus continuous power [W]

M_{rms} Effective torque in Nm

n_m Average speed in min⁻¹

k Factor for motor and controller efficiency = 1.25

3. Add **powers of all axes** at common DC bus and put them into relation to rated power of supply unit

⇒ Partial load of P_{DC_cont} is available

4. Determine **power factor TPF** for partial load (TPF = Total Power Factor)

For the value **TPF** at rated power and **TPF₁₀** (at 10% of rated power), see technical data (mains voltage) of the component.

5. Calculate **mains connected load**

$$S_{LN} = \frac{P_{DC}}{TPF}$$

S_{LN} Mains connected load [VA]

P_{DC} DC bus continuous power [W]

TPF Total Power Factor λ

6. Calculate **mains-side phase current**

3-phase:
$$I_{LN} = \frac{S_{LN}}{U_{LN} \sqrt{3}}$$

1-phase:
$$I_{LN} = \frac{S_{LN}}{U_{LN}}$$

I_{LN} Mains-side phase current in [A]

S_{LN} Mains connected load [VA]

U_{LN} Voltage between phases of mains [V]

7. Select **mains contactor**

8. Determine **mains circuit breaker and line cross section**

See [chapter 15.3.5 "Dimensioning the Line Cross Sections and Fuses"](#) on page 266

15.2.2 Calculating the Inrush Current

For calculating the inrush current, take all devices connected to mains voltage into account. The resulting inrush current is the sum of the inrush currents of the individual devices.

 For the data of the **inrush current** $I_{L_trans_max_on}$, see Project Planning Manual "Rexroth IndraDrive Supply Units and Power Sections" → Chapter of the respective device → "Technical Data" → "Basic Data" → table "Data for Mains Voltage Supply".

Duration of Inrush Current

For components with resistance charge, the inrush current profile is according to an exponential function. After the delay t_d is over, the charging process is completed.

Data for calculating the delay t_d : See [chapter 15.4.1 "Charging the DC Bus"](#) on page 276

15.2.3 Calculations for the Mains Harmonics

Harmonic Load THD

The harmonic load of the mains is described by the THD (total harmonic distortion):

$$THD = \sqrt{\sum_{n=2}^{40} \left(\frac{I_n}{I_1}\right)^2}$$

- I_n Harmonic current of the n-th harmonic
- I_1 rms value of the 1st harmonic (fundamental wave)
- I_2 rms value of the 2nd harmonic
- I_n rms value of the n-th harmonic

Fig. 15-33: THD (Total Harmonic Distortion)

Harmonic Content / Distortion Factor k

The harmonic content of, for example, the mains current is described by the distortion factor k. The distortion factor contains all alternating components, both those of the fundamental wave (I_1) and of the harmonics (I_k). Direct components (I_0) are not contained.

Calculations

$$k_i = \frac{\sqrt{\sum_{k=2}^n I_k^2}}{\sqrt{\sum_{k=1}^n I_k^2}} = \sqrt{\frac{I_2^2 + I_3^2 + \dots}{I_1^2 + I_2^2 + I_3^2 + \dots}}$$

k_i	Distortion factor or harmonic content
I_k	Harmonic current of the k-th harmonic
I_1	rms value of the 1st harmonic (fundamental wave)
I_2	rms value of the 2nd harmonic

Fig. 15-34: Distortion Factor k or Harmonic Content**Power Factor $\cos\phi_1$ or DPF for Calculating the Wattless Power Load of the Mains**

The power factor $\cos\phi_1$ or DPF (distortion power factor) is used to calculate the wattless power load of the mains:

$$DPF = \cos\phi_1 = \frac{P_{\text{netz}}}{S_{1LN}}$$

P_{netz}	Effective mains power
S_{1LN}	Apparent mains power of fundamental wave

Fig. 15-35: Power Factor $\cos\phi_1$ / DPF**Power Factor $\cos\phi$ or TPF (λ)**

The power factor $\cos\phi$ or TPF is used for dimensioning mains components (transformer, fuse, etc.):

$$TPF = \lambda = \cos\phi = \frac{P_{\text{netz}}}{S_{LN}}$$

P_{netz}	Effective mains power
S_{LN}	Apparent mains power

Fig. 15-36: Power Factor $\cos\phi$ / TPF / λ 

Only for sinusoidal values does the power factor $\cos\phi$ equal the total power factor TPF (λ).

15.2.4 Mains Voltage Unbalance

The voltage unbalance is described by a three-phase system consisting of the combination of the following systems:

- Clockwise AC system (positive-sequence system U_m)
- Counter-clockwise AC system (negative-sequence system U_g)
- DC system (U_0)

$$\frac{|U_x - U_{AVE}|}{U_{AVE}} \times 100\%$$

U_x Phase-to-phase voltage with highest deviation from average value
 U_{AVE} = $(U_{12} + U_{23} + U_{31}) / 3$; U_{12} , U_{23} , U_{31} being voltages between the phases

Fig. 15-37: Definition of Voltage Unbalance

15.2.5 Calculating the Allowed Continuous Power in the Common DC Bus

By interconnecting the DC bus connections of several HCS02 and HLB01 drive controllers, the regenerative power and continuous power generated in the common DC bus are equally distributed to all IndraDrive C devices with braking resistor.

Distribution to the involved devices takes place with high balancing factor.

For Central Supply and Group Supply with DC Bus Connection

$$\sum P_{BD, Geräte} = \sum (P_{BD, HCS} + P_{BD, HLB}) \times f$$

$P_{BD, Geräte}$ Braking resistor continuous power that all devices at common DC bus can process in continuous operation, in kW
 $P_{BD, HCS02}$ Braking resistor continuous power that the drive controller can process in continuous operation, in kW
 $P_{BD, HLB01}$ Braking resistor continuous power that the additional braking resistor module can process in continuous operation, in kW
 f Balancing factor for parallel operation

Fig. 15-38: Available Braking Resistor Continuous Power at Common DC bus

$$\sum P_{ZW, Geräte} = \sum P_{ZW} \times f$$

$P_{ZW, Geräte}$ Available DC bus continuous power at common DC bus, in kW
 P_{ZW} DC bus continuous power of the individual devices, in kW
 f Balancing factor for parallel operation

Fig. 15-39: Available DC Bus Continuous Power at Common DC Bus

Calculations

15.3 Determining Components in the Mains Connection

15.3.1 Determining the Mains Choke

When using mains chokes, take their effect on the connected drive controllers into account. Due to their inductance, mains chokes have a smoothing effect on the current and thereby reduce harmonics.

Take the nominal current of the mains choke into account to have the inductance of the mains choke available.

Some mains chokes are assigned to certain drive controllers (see technical data of the drive controller "Data for mains voltage supply → Assigned type of mains choke").

15.3.2 Determining the Mains Filter

Criteria for Selecting the Mains Filter

Take the following criteria into account for selecting the appropriate mains filter:

- EMC limit value class on site
- Ambient conditions on site
- Harmonics on mains voltage on site
- Loading by mains voltage and mains frequency on site
- Loading by harmonics on site
- Loading by mains-side phase current
- Total length of connected power cables
- Sum of leakage capacitances
- Clock frequency of drive controller

How to Proceed for Selecting the Mains Filter

The selection of the mains filter is significantly determined by the operating conditions. How to proceed for selecting the mains filter:

1. Determine the required EMC limit value class for the application.
2. Determine the maximum applied mains voltage.
Observe that not all Rexroth IndraDrive mains filters are suited for a mains voltage of 3 AC 500 V.
Check whether the mains voltage of the mains filter is loaded with harmonics and still allowed for the mains filter.
Allowed operating data depending on existing harmonics: See [chapter 18.3 "Emitted Harmonics on Mains Current and Mains Voltage" on page 290](#)
If necessary, reduce the harmonics on site.
3. Determine the kind of mains connection, such as central supply, group supply etc. (to do this, it is useful to outline the involved components and their interaction).
4. Calculate the **mains-side phase current** of the mains filter.
Procedure for calculating the mains-side phase current: See [chapter 15.2.1 "Calculating the Mains-Side Phase Current" on page 260](#)
For selecting the components, calculate the effective rms value.
Check or determine the maximum occurring ambient temperature. Select a mains filter with higher nominal current, when the ambient temperature is above 45 °C.
5. Select a mains contactor the nominal current of which does not exceed nominal current of the mains filter.

6. Determine the number of drive axes.
An HMD drive controller, for example, counts as two drive axes.
7. Determine the total length of the connected power cables.
8. Determine the sum of the leakage capacitances on the load side of the mains filter. The sum of the leakage capacitances results from the number of operated axes and the length of the connected power cables.
Procedure for determining the leakage capacitance: See [chapter 15.3.6 "Determining the Leakage Capacitance" on page 272](#)
9. Select the appropriate mains connection (supply unit/converter, mains choke, mains filter) from the corresponding tables in [chapter 8.3 "Mains Connection Supply Units and Converters" on page 106](#).

The **capacity of the mains filters** regarding the maximum allowed number of drive controllers and the maximum allowed total power cable length depends on whether you use an HMV supply unit or supply other drive controllers with HCS drive controllers. For supply by an HMV supply unit, the allowed number and allowed total length are higher.

Notes on Installation



When using HNF01, NFD03, HNS02 or HNK01 mains filters at **mains grounded via outer conductor**, install an isolating transformer between mains and mains filter.

15.3.3 Determining Mains Transformer DLT



When using HNF01, NFD03, HNS02 or HNK01 mains filters at **mains grounded via outer conductor**, install an isolating transformer between mains and mains filter.

How to Proceed for Selecting the Mains Transformer

The selection of the mains transformer is significantly determined by the conditions at the connection point and the supply unit used.

Procedure

1. Determine S_{k_min} (minimum short circuit power of the mains for failure-free operation) of the supply unit used.
See Project Planning Manual "Rexroth IndraDrive Supply Units and Power Sections", "Data for Mains Voltage Supply"
2. In the table "Mains Classified According to Mains Short Circuit Power and Mains Internal Resistance", read the inductance L_{k_min} of the mains phase in row of S_{k_min} .
3. Determine the short circuit power S_k present at the connection point.
4. In the table "Mains Classified According to Mains Short Circuit Power and Mains Internal Resistance", read the inductance of the mains phase in row of S_k .
5. Calculate difference L : $L_{k_min} - L_k$
6. Calculate apparent power S_{Trafo} :
$$S_{Trafo} = (U_{LN}^2 \times u_k) / (L \times 6.28 \times f_{LN})$$

Relative short-circuit voltage u_k of DLT transformers is approx. 4%.

15.3.4 Mains Contactor and Fusing

To protect the supply mains and the components in the supply feeder (lines, mains contactor, mains filter, mains choke, converter, supply unit, etc.) for the case of a short circuit, install fuses in the supply feeder.

Calculations

Operation Under Rated Conditions

In operation under rated conditions, the component is operated in individual supply with the rated power P_{DC_cont} .

 For the data of **mains contactor, fusing** and the required **connection cross section** in operation under rated conditions, see Project Planning Manual "Rexroth IndraDrive Supply Units and Power Sections" → Chapter of the respective device → "Technical Data" → "Basic Data" → table "Data for Mains Voltage Supply".

Operation at Partial Load

If several drive controllers are to be operated at partial load (power smaller than rated power) at one mains circuit breaker and one mains contactor only, add the mains-side phase currents and inrush currents calculated for the individual drives and therefor determine the mains circuit breaker.



Dimensioning the fuse for operation at partial load

The nominal current of the selected fuse before the drive system mustn't be greater than the mains circuit breaker of the smallest converter or supply unit.

Use more powerful converters or supply units in the drive system.

For dimensioning line cross sections and fuses, see also [chapter 15.3.5 "Dimensioning the Line Cross Sections and Fuses "](#) on page 266.

Fusing Branches within the Control Cabinet

In the wiring of the drive system devices, there are branches run from main lines to short circuit protection devices.

In accordance with EN 60204-1:2005, 7.2.8, such supply lines to short circuit protection devices branching off main lines do not need to be especially protected against short circuit, when the following requirements have been fulfilled:

- The supply lines to the short circuit protection device have at least the cross section of the conductors continuing the line from the short circuit protection device (line cross sections from and to motor circuit breaker have the same size).
- No supply line to the short circuit protection device is longer than 3 m.
- The lines are protected against external influence by a housing or a wiring duct.
- The lines are not run close to combustible material.

15.3.5 Dimensioning the Line Cross Sections and Fuses

Dimensioning the line cross sections and fuses in the supply feeder and branches to the drive system:

1. Determine current in supply feeder of drive system and correct it with correction factors for [ambient temperature](#) and [bundling](#).
(In the technical data of the components in section "Data for Mains Voltage Supply", you can find standardized data for connection cross section and mains circuit breaker at operation under rated conditions.)
2. Determine country of use ("international except for USA/Canada" or "USA/Canada")
3. Determine installation type (e.g. B1 or B2)
4. In table row "Current I", select value immediately above the value determined in the first step
5. In table row "Nominal current fuse", read corresponding fuse

Calculations

6. In table row "Cross section A ...", read corresponding required cross section

Country of use: International except for USA/Canada		
Current I	Nominal current fuse	Cross section A for installation type B1
A	A	mm ²
1,6	2	1,5
3,3	4	Minimum cross section acc. to EN 60204-1:2006, table 5 (Main circuits; outside of hous- ings; permanently installed; sin- gle-core lines; stranded wire de- sign class 2)
5,0	6	
8,6	10	
10,3	16	
13,5	16	
18,3	20	2,5
22	25	4
28	32	6
31	40	6
35	40	10
44	50	10
59	63	16
77	80	25
96	100	35
117	125	50
149	160	70
180	200	95
208	250	120
227	250	150
257	315	185
301	355	240
342	400	300

Tab. 15-2: Line Cross Sections and Fuses, B1 According to EN 60204-1:2006, Table 6, as of 150mm² DIN IEC 60364-5-52:2004, Table B.52-4

Calculations

Country of use: International except for USA/Canada		
Current I	Nominal current fuse	Cross section A for installation type B2
A	A	mm ²
1,6	2	0,75
3,3	4	Minimum cross section acc. to EN 60204-1:2006, table 5 (Main circuits; outside of hous- ings; permanently installed; mul- ti-core lines)
5,0	6	
8,5	10	
10,1	16	1,0
13,1	16	1,5
17,4	20	2,5
23	25	4
28	32	6
30	40	6
35	40	10
40	50	10
54	63	16
70	80	25
86	100	35
103	125	50
130	160	70
156	200	95
179	200	120
195	224	150
221	250	185
258	315	240
294	355	300

Tab. 15-3: Line Cross Sections and Fuses, B2 According to EN 60204-1:2006, Table 6, as of 150mm² DIN IEC 60364-5-52:2004, Table B.52-4

Calculations

Country of use: International except for USA/Canada		
Current I	Nominal current fuse	Cross section A for installation type E
A	A	mm ²
1,6	2	0,75
3,3	4	Minimum cross section acc. to EN 60204-1:2006, table 5 (outside of housings; perma- nently installed; multi-core lines)
5,0	6	
8,3	10	
10,4	16	
12,4	16	1
16,1	20	1,5
22	25	2,5
28	32	4
30	40	4
37	40	6
44	50	10
52	63	10
70	80	16
88	100	25
110	125	35
133	160	50
171	200	70
207	250	95
240	315	120
277	355	150
316	400	185
374	425	240
432	500	300

Tab. 15-4: Line Cross Sections and Fuses, E According to EN 60204-1:2006, Table 6, as of 150mm² DIN IEC 60364-5-52:2004, Table B.52-10

Calculations

Country of use: USA/Canada		
Current I	Nominal current fuse	Cross section A
A	A	AWG
1,6	2	14 Minimum cross section acc. to UL 508 A:2007, chapter 29.6
3,3	4	14
5,0	6	14
8,3	10	14
13	15	14
15	20	14
20	25	12
30	40	10
50	70	8
65	80	6
85	100	4
100	110	3
115	125	2
130	150	1
150	175	1/0
175	200	2/0
200	225	3/0
230	250	4/0
255	300	250 kcmil
285	300	300 kcmil
310	350	350 kcmil
335	350	400 kcmil
380	400	500 kcmil
420	450	600 kcmil

Tab. 15-5: Line Cross Sections and Fuses According to UL508A:2007, Table 28.1

Dimensioning variables of the table values

1. Ambient temperature T_A of routed lines ≤ 40 °C
2. Temperature T_L at conductor at nominal current: 90 °C for UL-listed lines (USA/Canada) or 70 °C for PVC lines
3. The nominal current of the fuse is approx. 10-20% above the nominal current I_{LN} of the converter/supply unit or the determined current of the drive system.
4. Installation types:

Calculations

- B1 in accordance with IEC 60364-5-52, e.g. stranded wires routed in cable duct
- B2 in accordance with IEC 60364-5-52, e.g. multi-core line routed in cable duct
- E in accordance with EN 60204-1, e.g. multi-core line routed on open cable tray
- In accordance with NFPA 79 (external wiring), UL508A (internal wiring), NEC, NFPA 70:
 - 1 cable with 3 conductors, 1 neutral conductor and 1 equipment grounding conductor
 - Routed in pipe on the wall

Internal wiring: Routing inside of control cabinet or inside of devices

External wiring: Routing outside of control cabinet

Field wiring: Data of cross sections of terminal connectors wired by the user (in the field)

5. Recommendation for design of the fuses:

- **International except for USA/Canada:**
 - Fuse-link in accordance with IEC 60269-1, characteristic gG (fuses)
 - Circuit breakers in accordance with IEC 60898-1/2, type B or C
 - Circuit breakers in accordance with IEC 60947-2/6-2
- **USA / Canada:**
 - Class J; 600 V



Correction factors

For deviating dimensioning variables, the corresponding standards specify correction factors.

Below you can find the correction factors for ambient temperature and numbers of routed lines and circuits. If necessary, multiply the determined current in the supply feeder with these factors.

Correction Factor Ambient Temperature

Ambient temperature T_A / °C	30	35	40	45	50	55	60
Correction factor according to EN 60204-1:2006, table D.1	0,87	0,93	1,00	1,1	1,22	1,41	1,73
Correction factor according to NFPA 79:2007, table 12.5.5(a)	0,88	0,94	1,00	1,1	1,18	1,32	1,52

Tab. 15-6: Correction Factor Ambient Temperature in Accordance with EN 60204-1:2006 and NFPA 79:2007

Calculations

Correction Factor for Bundling of Lines (Installation Methods B2 and E) and Circuits (Installation Method B1¹⁾)

Number of lines	1	2	3	4	5
Correction factor according to EN 60204-1:2006, table D.2	1	1,25	1,43	1,54	1,67
Correction factor according to NFPA 79:2007, table 12.5.5(b)	1	1,25			

1) Three single cores (L1, L2, L3) for mains supply of a device are to be considered as one circuit.

Tab. 15-7: Correction Factor for Bundling of Lines and Circuits in Accordance with EN 60204-1:2006 and NFPA 79:2007

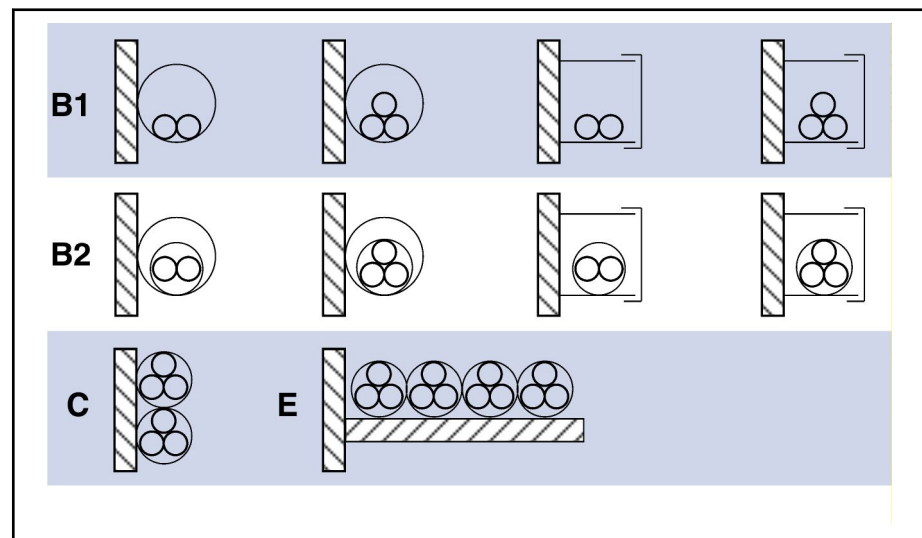

B1 Conductor in installation pipes and in installation channels to be opened

B2 Cables or lines in installation pipes and in installation channels to be opened

C Cables or lines on walls

E Cables or lines on open cable trays.

Fig. 15-40: Installation methods (compare IEC 60364-5-52; VDE0298-7; EN 60204-1)

15.3.6 Determining the Leakage Capacitance

The capacitances which generate so-called leakage currents against ground at the outputs of inverters are regarded as leakage capacitance C_{ab} . The decisive values for the total value C_{ab_g} of the leakage capacitance are:

- Capacitances of output filters
- Capacitances of power cables (capacitance per unit length against shield and ground wire)
- Capacitances of motors (winding capacitance against housing)



The capacitance per unit length of the hybrid cable of Rexroth IndraDrive Mi is insignificant for determining the leakage capacitance, because the hybrid cable is at the DC bus and not at the output of the inverter.

The leakage capacitance consists of the values of power cable and motor of all individual drives operated at the mains filter.

Calculation:

$$C_{ab_g} = C_{ab_Mg} + C_{ab_Kg}$$

C_{ab_g} Total value of leakage capacitance
 C_{ab_Mg} Total value of leakage capacitance of motor
 C_{ab_Kg} Total value of leakage capacitance of cable

Fig. 15-41: Total Leakage Capacitance

The total capacitance C_{ab_Mg} results from the sum of capacitances of the individual motors. For these individual capacitances, see documentation of the motor. For a list of selected values, see Appendix of this documentation under [chapter 18.2 "Leakage Capacitances" on page 287](#).

$$C_{ab_Mg} = C_{ab(Motor_1)} + C_{ab(Motor_2)} \dots + C_{ab(Motor_n)}$$

$C_{ab(motor)}$ Leakage capacitance of a motor
Fig. 15-42: Total Leakage Capacitance of Motor

$$C_{ab_Kg} = C_{Y_K\ typ (K1)} \times l_{(K1)} + C_{Y_K\ typ (K2)} \times l_{(K2)} \dots + C_{Y_K\ typ (Kn)} \times l_{(Kn)}$$

$C_{Y_K\ typ}$ Capacitance per unit length of cables
 C_{ab_Kg} Total leakage capacitance of cables

Fig. 15-43: Total leakage capacitance of cables

The total capacitance C_{ab_Kg} consists of the sum of capacitances of the individual power cables. For the individual capacitances per unit length, see the technical data of the power cables. For a list of selected values, see Appendix of this documentation under [chapter 18.2 "Leakage Capacitances" on page 287](#).

15.3.7 Determining the Allowed Operating Data of Mains Filters

Reducing Allowed Operating Voltage Depending on Actual Temperature Rise Due to Harmonics

The mains filters may only be operated in the allowed mains voltage range. Harmonics (f_n) at the system voltage cause additional temperature rise of the dielectric of the capacitors used in the filter. Calculating the temperature rise:

$$\Delta T_n = \frac{10 \times (U_{Mn})^2}{(U_{Gn})^2} [K]$$

U_{Mn} Measured voltage value at frequency f_n (harmonic)
 U_{Gn} Voltage limit value for frequency f_n
 ΔT_n Calculated temperature rise of the dielectric for frequency f_n

Fig. 15-44: Calculating the Temperature Rise of the Dielectric

The temperature rises have to be added up for all frequencies $f_n \geq f_k$ (f_k : frequency at which the voltage derating of the filter starts):

Calculations

$$\Delta T_{ges} = \sum_{v=1}^{\infty} \Delta T_v = \sum_{v=1}^{\infty} \frac{10 \times (U_{Mv})^2}{(U_{Gv})^2} [K] \leq 10 [K]$$

U_{Mv} Voltage value at frequency f_v

U_{Gv} Voltage limit value for frequency f_v

ΔT_{ges} Calculated temperature rise of the dielectric for all frequencies

Fig. 15-45: Calculating the Temperature Rise of the Dielectric for all Frequencies

With the above formulas and the measured voltages, it is possible to determine the real load of a filter with voltages of higher frequencies. To this end, the rms value of the voltage on the mains side of the filter with all occurring frequencies (higher than f_k) must be measured by means of a Fourier analysis for all combinations of line/line and line/PE. You always have to measure the voltages under conditions of operation at the nominal working point, the filter having been installed. By means of the measured values, it is then possible to calculate the temperature rise. To do this, the limit values of the following diagram are read at the respective frequency and used in the formula together with the measured value.

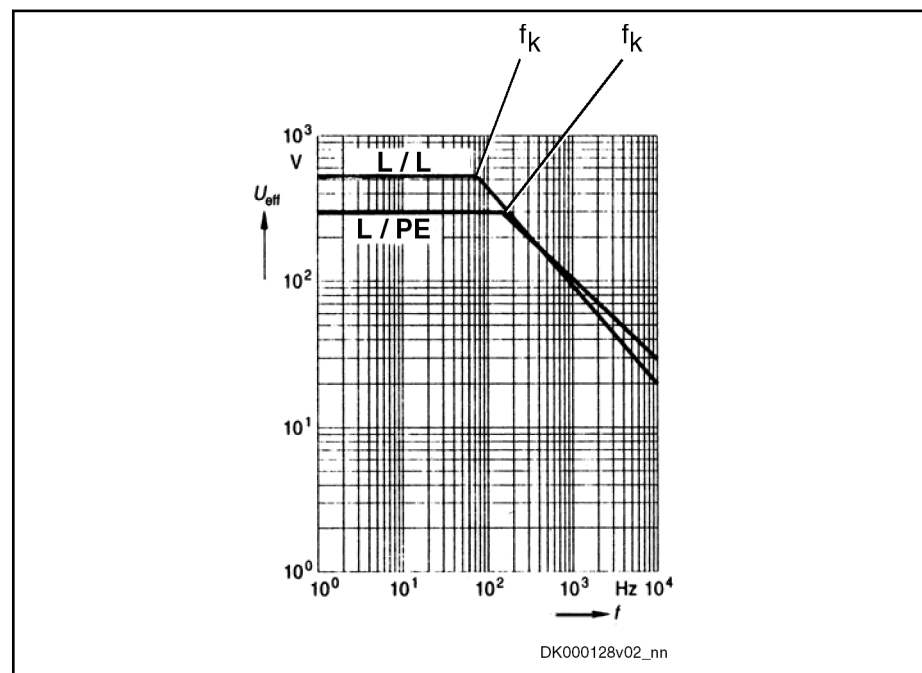

L / L Line / line

L / PE Line / PE

Fig. 15-46: Derating

If the total of the temperature values is greater than 10 K, the harmonics have to be reduced by means of appropriate measures.

Current Reduction in the Case of Overtemperature

The mains filters recommended by Rexroth have been sized for an ambient temperature of 45 °C.

For higher temperatures, reduce the mains current according to the following formula:

Calculations

$$I = I_{Netz} \times \sqrt{\frac{85 - T_{amb}}{40}}$$

 I_{Netz}

Nominal current of filter at 45 °C

 T_{amb}

Ambient temperature on site

*Fig. 15-47:**Current Reduction in the Case of Overtemperature*

Calculations

15.4 Other Calculations

15.4.1 Charging the DC Bus

To **estimate** the delay t_d which a supply unit or a converter needs to charge the DC bus, this applies:

Delay time t_d is the time which passes from connection of mains voltage to the device (from status "ready for operation") to status "drive ready".

(See also parameter "P-0-0115, Device control: status word" or "S-0-0135, Drive status word")

Delay t_d

$$t_d = R_{\text{lade}} \times 1,2 \times C_{\text{DC}} \times 3 + 200\text{ms}$$

t_d	Delay
R_{lade}	Effective charging resistance
C_{DC}	Effective DC bus capacitance
200 ms	Waiting time until charging process is completed

Fig. 15-48: Delay for Three-Phase Operation

The interrelation applies to three-phase mains connection. For single-phase mains operation, take the double time or control following processes via the status "P-0-0115, Device control: status word".

Delay t_d for HCS02

In HCS02 converters, the DC bus is charged via the **integrated** braking resistor $R_{\text{DC_Bleeder}}$.

The delay t_d is approx. 2 seconds, **independent** of the DC bus capacitance.

Effective Charging Resistance with Several Mains Supplies

Effective charging resistance of all drive controllers at common DC bus connected to mains voltage:

$$\frac{1}{R_{\text{lade}}} = \frac{1}{R_{\text{lade}_1}} + \frac{1}{R_{\text{lade}_2}} \dots + \frac{1}{R_{\text{lade}_n}}$$

Fig. 15-49: Several Charging Resistances

Effective Charging Resistance with One Mains Supply

Effective charging resistance of one drive controller at common DC bus connected to mains voltage:

$$R_{\text{lade}} = \frac{U_{\text{LN}}}{I_{\text{L_trans_max}}(on)}$$

U_{LN}	Applied mains voltage
$I_{\text{L_trans_max}}(on)$	Inrush current at applied mains voltage

Fig. 15-50: Charging Resistance



Charging resistance of HCS03 converters

In HCS03.1E-W0070...0150 converters, the DC bus is charged via **integrated** resistors for charging current limitation, and in HCS03.1E-W0210 converters, it is charged via a thyristor circuit:

$$R_{indep} = \frac{U_{LN}}{I_{L_trans_max_on}}$$

The charging ability is limited by the properties of the integrated resistor; its resistance value clearly rises with increasing thermal load.



For the data of the **inrush current** $I_{L_trans_max_on}$ and the **mains voltage** U_{LN} , see Project Planning Manual "Rexroth IndraDrive Supply Units and Power Sections" → Chapter of the respective device → "Technical Data" → "Basic Data" → table "Data for Mains Voltage Supply".

Resulting DC Bus Capacitance

Effective DC bus capacitance of all devices at common DC bus:

$$C_{DC} = C_{DC1} + C_{DC2} \dots + C_{DCn} + C_{DCent}$$

C_{DC} Capacitance in DC bus

Fig. 15-51: DC Bus Capacitance



For the data of the **capacitance in DC bus** C_{DC} , see Project Planning Manual "Rexroth IndraDrive Supply Units and Power Sections" → Chapter of the respective device → "Technical Data" → "Basic Data" → table "Data of Power Section - DC bus".

15.4.2 Calculating Speed Characteristic and Braking Time With DC Bus Short Circuit (ZKS)

Components equipped with the ZKS function (e.g HLB01) short-circuit the DC bus via the braking resistor when the DC bus short circuit (ZKS) is active. At synchronous motors with permanent magnet excitation, the short circuit causes speed-dependent braking torque.

The braking torque and the braking time can be estimated with the following formulas.



The calculation formulas below can only be applied to rotary motors for which, in addition, the relation L_d / L_q must be approx. 1.

Basic Formula 1

$$\omega_0 = 2\pi \frac{n_0}{60}$$

ω_0 [Initial angular velocity motor] = s^{-1}

n_0 [Motor speed at beginning of ZKS] = min^{-1}

Fig. 15-52: Initial Angular Velocity

Calculations

Basic Formula 2

$$R' = R_S + \frac{R_{DC_Bleeder} \pi^2}{18}$$

R' [Transformed resistance] = Ω
 R_S [Winding resistance motor] = Ω ; see P-0-4048 *0.5
 $R_{DC_Bleeder}$ [Effective braking resistance with ZKS] = Ω
 Fig.15-53: *Transformed Resistance*

Occurring Torque

$$M_{\max} = \frac{K_M^2}{6 * Z_p * L}$$

M_{\max} Maximum occurring torque (friction not taken into account)
 K_M [Torque constant motor] = Nm/A; see P-0-0051
 L [Winding inductance motor] = H; see P-0-4016
 Z_p Number of pole pairs motor; see P-0-0018
 Fig.15-54: *Occurring Torque*

Braking Torque vs. Angular Velocity

$$M(\omega) = \frac{K_M^2 * \omega * R'}{3(R'^2 + L^2 * Z_p^2 * \omega^2)}$$

K_M [Torque constant motor] = Nm/A; see P-0-0051
 ω [Angular velocity motor] = s^{-1}
 R' [Transformed resistance] = Ω
 L [Winding inductance motor] = H; see P-0-4016
 Z_p Number of pole pairs motor; see P-0-0018
 Fig.15-55: *Braking Torque Depending on Angular Velocity*

Braking Torque vs. Speed

$$M(n) = \frac{K_M^2 * \pi * n * R'}{90 * \left(R'^2 + \frac{L^2 * Z_p^2 * n^2 * \pi^2}{900} \right)}$$

K_M [Torque constant motor] = Nm/A; see P-0-0051
 n [Motor speed] = min^{-1}
 R' [Transformed resistance] = Ω
 L [Winding inductance motor] = H; see P-0-4016
 Z_p Number of pole pairs motor; see P-0-0018
 Fig.15-56: *Braking Torque Depending on Motor Speed*

Braking Time From Initial Velocity to Determined Speed

$$t_s(X) \approx \frac{3 * J_{red}}{R' * K_M^2} * \left[\frac{z_p^2 * L^2 * \omega_0^2}{2} * \left(\frac{X^2}{10^4} - 1 \right) + R'^2 * \ln \left(\frac{X}{100} \right) \right]$$

t_s	[Braking time] = s
J_{red}	[Inertia from load and motor at motor shaft] = kgm ²
R'	[Transformed resistance] = Ω
K_M	[Torque constant motor] = Nm/A; see P-0-0051
z_p	Number of pole pairs motor; see P-0-0018
L	[Winding inductance motor] = H; see P-0-4016
ω_0	[Initial angular velocity motor] = s ⁻¹
X	[Part of initial speed] = %

Fig. 15-57: Duration From Initial Speed to Speed X

Calculation with $X = 0$ results in infinite braking time, because the theoretical speed characteristic is an asymptote tending to 0. The motor nevertheless comes to standstill, because in practical application a friction torque takes effect in addition to the braking torque due to ZKS (DC bus short circuit).



Check calculation by means of measurement

The calculation provides a result which can be used for the first estimation of the braking behavior. Other influences, such as energy balance in the DC bus, tolerances and environmental influences, take effect on the actually occurring braking behavior.

Measure the actually occurring braking time in the installation!

16 Environmental Protection and Disposal

16.1 Environmental Protection

Production Processes	The products are made with energy- and resource-optimized production processes which allow re-using and recycling the resulting waste. We regularly try to replace pollutant-loaded raw materials and supplies by more environment-friendly alternatives.														
No Release of Hazardous Substances	Our products do not contain any hazardous substances which may be released in the case of appropriate use. Normally, our products will not have any negativ influences on the environment.														
Significant Components	Basically, our products contain the following components: <table> <tr> <td>Electronic devices</td> <td>Motors</td> </tr> <tr> <td>• steel</td> <td>• steel</td> </tr> <tr> <td>• aluminum</td> <td>• aluminum</td> </tr> <tr> <td>• copper</td> <td>• copper</td> </tr> <tr> <td>• synthetic materials</td> <td>• brass</td> </tr> <tr> <td>• electronic components and modules</td> <td>• magnetic materials</td> </tr> <tr> <td></td> <td>• electronic components and modules</td> </tr> </table>	Electronic devices	Motors	• steel	• steel	• aluminum	• aluminum	• copper	• copper	• synthetic materials	• brass	• electronic components and modules	• magnetic materials		• electronic components and modules
Electronic devices	Motors														
• steel	• steel														
• aluminum	• aluminum														
• copper	• copper														
• synthetic materials	• brass														
• electronic components and modules	• magnetic materials														
	• electronic components and modules														

16.2 Disposal

Return of Products	Our products can be returned to our premises free of charge for disposal. It is a precondition, however, that the products are free of oil, grease or other dirt. Furthermore, the products returned for disposal must not contain any undue foreign material or foreign components. Send the products "free domicile" to the following address: Bosch Rexroth AG Electric Drives and Controls Buergermeister-Dr.-Nebel-Strasse 2 97816 Lohr am Main, Germany
Packaging	The packaging materials consist of cardboard, wood and polystyrene. These materials can be recycled anywhere without any problem. For ecological reasons, please refrain from returning the empty packages to us.
Batteries and Accumulators	Batteries and accumulators can be labeled with this symbol.  The symbol indicating "separate collection" for all batteries and accumulators is the crossed-out wheeled bin. The end user within the EU is legally obligated to return used batteries. Outside the validity of the EU Directive 2006/66/EC keep the stipulated directives. Used batteries can contain hazardous substances, which can harm the environment or the people's health when they are improper stored or disposed of. After use, the batteries or accumulators contained in Rexroth products have to be properly disposed of according to the country-specific collection.
Recycling	Most of the products can be recycled due to their high content of metal. In order to recycle the metal in the best possible way, the products must be disassembled into individual modules.

Environmental Protection and Disposal

Metals contained in electric and electronic modules can also be recycled by means of special separation processes.

Products made of plastics can contain flame retardants. These plastic parts are labeled according to EN ISO 1043. They have to be recycled separately or disposed of according to the valid legal requirements.

17 Service and Support

Our worldwide service network provides an optimized and efficient support. Our experts offer you advice and assistance should you have any queries. You can contact us **24/7**.

Service Germany Our technology-oriented Competence Center in Lohr, Germany, is responsible for all your service-related queries for electric drive and controls.

Contact the **Service Helpdesk & Hotline** under:

Phone: **+49 9352 40 5060**
Fax: **+49 9352 18 4941**
E-mail: service.svc@boschrexroth.de
Internet: <http://www.boschrexroth.com>

Additional information on service, repair (e.g. delivery addresses) and training can be found on our internet sites.

Service worldwide Outside Germany, please contact your local service office first. For hotline numbers, refer to the sales office addresses on the internet.

Preparing information To be able to help you more quickly and efficiently, please have the following information ready:

- Detailed description of malfunction and circumstances resulting in the malfunction
- Type plate name of the affected products, in particular type codes and serial numbers
- Your contact data (phone and fax number as well as your email address)

18 Appendix

18.1 System Elements - Product Overview, Short Designations

Short designation	System element / product	Description
CSB01.1	Control section single-axis	Scope of functions BASIC
CDB01.1	Control section double-axis	
CSH01.1, CSH01.2, CSH01.3	Control section single-axis	Scope of functions ADVANCED
CSB02.1	Control section single-axis (2nd generation)	Scope of functions BASIC
CDB02.1	Control section double-axis (2nd generation)	
CSH02.1	Control section single-axis (2nd generation)	Scope of functions ADVANCED
CSE02.1	Control section single-axis (2nd generation)	Scope of functions ECONOMY
CZ 1.2	Additional capacitor	Capacitor with touch guard
DLT	Isolating transformer	
DST	Matching transformer	
HAT01	Control unit for motor holding brake	Is used for the "Safe braking and holding system"
HAB01	Fan unit	Blower to be mounted to certain HMV01 and HMS01
HAC01	Housing for control sections	
HAS01	Basic accessory	Accessories for connecting the components (contact bars, fixing material ...)
HAS02	Shield connection	Accessory for connecting shielded motor cables to power sections
HAS03	Control cabinet adapter	Accessory for adjusting the mounting depth
HAS04	Capacitor	Accessory DC bus capacitors against ground potential
HAS05	Cables, connectors, adapters	Accessories to adjust electrical interfaces
HAS06	Closure coupling, closure fitting, tube piece	Connection accessories for liquid cooling
HCS02.1	Drive controller	Converter
HCS03.1	Drive controller	Converter
HLB01.1C	DC bus resistor unit	For IndraDrive C
HLB01.1D	DC bus resistor unit	For IndraDrive M
HLC01.1C	DC bus capacitor unit	For IndraDrive C
HLC01.1D	DC bus capacitor unit	For IndraDrive M
HLR01	Braking resistor	
HMD01.1	Drive controller	Power section, double-axis
HMF01.1	Motor filter	
HMS01.1	Drive controller	Power section, single-axis

Appendix

Short designation	System element / product	Description
HMS02.1	Drive controller	Power section, single-axis
HMV01.1E	Supply unit	Supply unit, infeeding
HMV01.1R	Supply unit	Supply unit, infeeding and regenerative
HMV02.1R	Supply unit	Supply unit, infeeding and regenerative
HMV02.1E	Supply unit	Supply unit, infeeding
HNH01.1	Mains filter	
HNL01.1	Mains choke	Designs for infeeding systems (E) Regenerative systems (R) in current-compensated design
HNL02.1	Mains choke	Mains choke with housing for control cabinet mounting
HNS02.1	Mains filter	Mains filter with integrated switch-disconnector and motor circuit breaker
HNK01.1	Mains filter	Mains filter with integrated mains choke, variant for mounting
KCU01	Drive connection box	Additional component of IndraDrive Mi product range, to connect KSM01 or KMS01 to HMV supply units or HCS converters
KCU02	Drive connection box	Additional component of IndraDrive Mi product range, to connect KSM02 or KMS02 to HMV supply units or HCS converters
KSM01 KSM02	Motor-integrated servo drive	Motor-integrated servo drive of IndraDrive Mi product range
KMS01 KMS02	Near motor servo drive	Near motor servo drive of IndraDrive Mi product range
MPB	Firmware	Scope of functions BASIC
MPD	Firmware	Scope of functions BASIC, double-axis
MPH	Firmware	Scope of functions ADVANCED
MSK	Synchronous motor	
NFD03.1	Mains filter	
RKL	Ready-made cable	Ready-made motor power cable
RKS	Ready-made cable	Ready-made control cable
RKG	Ready-made cable	Ready-made encoder cable
RKH	Ready-made cable	System cable of IndraDrive Mi product range
VCP01	Comfort operator terminal	Variant to be plugged on
VCP02	Operator terminal	Variant for assembly
VCP05	Operator terminal	Variant for assembly
VCP08	Operator terminal	Variant for assembly

Short designation	System element / product	Description
VCP20	Operator terminal	Variant for assembly
VCP25	Operator terminal	Variant for assembly

Tab. 18-1: Product Short Designations

18.2 Leakage Capacitances

18.2.1 Leakage Capacitance of Motors

The data of the typical leakage capacitance refer to the total capacitance of the power connections U, V, W against the motor housing. The tables below contain excerpts from the technical data of motors:

Leakage Capacitance

Type	Leakage capacitance of the component	
	C_{ab} nF	
MSM019A-0300-NN-__-__	0,3	
MSM019B-0300-NN-__-__	0,7	
MSM031B-0300-NN-__-__	0,7	
MSM031C-0300-NN-__-__	1,4	
MSM041B-0300-NN-__-__	1,3	

Last modification: 2008-11-20

Tab. 18-2: MSM019A-0300-NN, MSM019B-0300-NN

Type	Leakage capacitance of the component	
	C_{ab} nF	
MSK030B-0900-NN-__-__-__	0,7	
MSK030C-0900-NN-__-__-__	1,3	
MSK040B-0450-NN-__-__-__	1,3	
MSK040C-0450-NN-__-__-__	2,0	
MSK043C-0600-NN-__-__-__	2,1	
MSK050B-0300-NN-__-__-__	2,1	
MSK050C-0300-NN-__-__-__	2,6	
MSK060B-0300-NN-__-__-__	2,1	
MSK060C-0300-NN-__-__-__	2,1	
MSK061B-0300-NN-__-__-__	1,8	
MSK061C-0300-NN-__-__-__	2,4	
MSK070C-0150-NN-__-__-__	3,8	

Last modification: 2008-12-10

Appendix

Type	Leakage capacitance of the component
	C_{ab} nF
MSK070D-0150-NN-__-__-__	5,0
MSK070E-0150-NN-__-__-__	6,3
MSK071C-0200-FN-__-__-__	4,6
MSK071D-0200-FN-__-__-__	6,9
MSK071E-0200-FN-__-__-__	8,9
MSK075C-0200-NN-__-__-__	
MSK075D-0200-NN-__-__-__	4,6
MSK075E-0200-NN-__-__-__	5,8
MSK076C-0300-NN-__-__-__	6,5
MSK100A-0200-NN-__-__-__	4,8
MSK100B-0200-NN-__-__-__	10,3
MSK100C-0200-NN-__-__-__	12,8
MSK100D-0200-NN-__-__-__	17,6
MSK101C-0200-FN-__-__-__	6,2
MSK101D-0200-FN-__-__-__	13,2
MSK101E-0200-FN-__-__-__	15,2
MSK103A-0300-NN-__-__-__	1,5
MSK103B-0300-NN-__-__-__	2,1
MSK103D-0300-NN-__-__-__	6,0
MSK131B-0200-NN-__-__-__	14,3
MSK131D-0200-NN-__-__-__	27,7

Last modification: 2008-12-10

Tab. 18-3: MSK - Leakage Capacitance (Excerpt)

See also Rexroth IndraDyn - Technical Data.

18.2.2 Leakage Capacitance of Power Cables

The power cables (bulk cables) of the "RKL" line by Rexroth have the capacitances per unit length listed below. The values refer to the sum of the single capacitances of power cores 1, 2 and 3 against the overall shield.

For power cables of the "RKH" line (hybrid cable of IndraDrive Mi), the value refers to the power cores L+, L- against the overall shield.

See also Rexroth Connection Cables - Data Sheet Bulk Cables.

Data Sheet Excerpt- Bulk Cables

Type	Cross section of power core	Leakage capacitance
	mm ²	$C_{Y_K,typ}$ nF/m
INK0653	1,0	0,6
INK0650	1,5	0,8
INK0602	2,5	0,7
INK0603	4,0	0,8
INK0604	6,0	0,8
INK0605	10,0	1,0
INK0606	16,0	1,2
INK0607	25,0	1,1
INK0667	35,0	1,2
INK0668	50,0	1,3

Last modification: 2007-11-08

Tab. 18-4: INK - Technical Data (Excerpt)

Data Sheet Excerpt- Bulk Cables

Type	Cross section of power core	Leakage capacitance
	mm ²	$C_{Y_K,typ}$ nF/m
REH0800	2,5	0,2

Tab. 18-5: REH - Technical Data (Excerpt)



Approximate calculation is allowed with the following values:

- Cross section 1 ... 6 mm²: 1 nF/m
- Cross section 10 ... 50 mm²: 1.2 nF/m

Appendix

18.3 Emitted Harmonics on Mains Current and Mains Voltage

18.3.1 General Information

Due to their electric design, the drive controllers and supply units generate harmonics in the mains current and on the mains voltage during operation at the mains. Using appropriate mains chokes decisively influences power factors and mains harmonics.

18.3.2 Harmonics of Mains Current

Harmonics of Supply Units, In-feeding (HMV...E and HCS)



The harmonics of the mains current are decisively reduced by the use of mains chokes.



For mains with mains frequency $f_{LN} = 60$ Hz, the values accordingly are multiples of $f_{LN} = 60$ Hz.

Formulas see chapter "Calculations".

		Without mains choke			With HNL Mains choke			With mains choke of higher inductance 1.7 x L_N of HNL		
		5%	50%	100%	5%	50%	100%	5%	50%	100%
k	I_{L_cont} f Hz	Ik/I1 %	Ik/I1 %	Ik/I1 %	Ik/I1 %	Ik/I1 %	Ik/I1 %	Ik/I1 %	Ik/I1 %	Ik/I1 %
1	50	100%	100%	100%	100%	100%	100%	100%	100%	100%
2	100	3	2	1	2	1	0,2	2	1	0,5
3	150	9	3	2	8	2	1	7	2	1
4	200	1	2	1	1	1	0,2	1	1	0,5
5	250	95	90	85	84	70	61	71	55	38
6	300	3	2	1	2	2	0,5	2	1	0,5
7	350	85	80	75	71	40	36	58	28	13
8	400	3	3	1	1	2	0,5	1	2	0,5
9	450	2	2	1	6	1	1	5	1	0,5
10	500	1	1	1	1	1	0,5	1	1	0,5
11	550	70	60	50	40	6	4,2	27	7	6,5
12	600	1	1	1	1	1	0,5	1	1	1
13	650	46	55	45	28	5	5,1	17	5	3
14	700	2	2	1	1	1	1	2	1	1
15	750	2	1	1	1	1	1	2	1	1
16	800	1	1	1	1	1	0,5	2	1	1
17	850	30	25	20	1	0,5	0,5	6	3	2,5
18	900	1	1	1	1	0,5	0,5	1	1	1
19	950	20	13	10	1	0,5	0,5	7	1	2

Appendix

		Without mains choke			With HNL Mains choke			With mains choke of higher inductance 1.7 x L _N of HNL		
		5%	50%	100%	5%	50%	100%	5%	50%	100%
	I _{Lcont}									
k	f	Ik/I1	Ik/I1	Ik/I1	Ik/I1	Ik/I1	Ik/I1	Ik/I1	Ik/I1	Ik/I1
	Hz	%	%	%	%	%	%	%	%	%
THD	%	173,08	156,32	144,86	120,86	81,18	71,24	98,08	62,61	41,12
ki		0,87	0,84	0,82	0,77	0,63	0,58	0,70	0,53	0,38

k = 1: Fundamental wave; k ≥ 2: Harmonics number
 I_{Lcont} Maximum input current (mains input continuous current), see technical data of device - Data for Mains Voltage Supply
 ki Distortion factor or harmonic content
 I_k Harmonic current of the k-th harmonic
 I₁ rms value of the 1st harmonic (fundamental wave)
 THD Total Harmonic Distortion
 Tab. 18-6: Harmonics HMV...E and HCS

Harmonics of Supply Units, Regenerative (HMV...R)



In the end application, the harmonics values are within the minimum and maximum values listed below. The harmonics values depend on

- Load distribution
- Conditions in the mains
- Mains pollution which other devices feed in the mains

If the degree of mains pollution generated by other devices is low, the resulting values of the harmonics in the mains current of the drive system are minimum values. If there is a high degree of mains pollution generated by other devices, the maximum values of the table can be reached in the worst case.

k	f	Ik/I1		
		Min.	Typ.	Max.
	Hz	%	%	%
1	50	100%	100%	100%
2	100	2,5	4	25
3	150	2	5	25
4	200	2	3	25
5	250	2	17	35
6	300	2	2	30
7	350	1,6	7	30
8	400	1	2	12
9	450	1	2	10
10	500	1	2	8
11	550	1	5	12

Appendix

k	f	Ik/I1		
		Min.	Typ.	Max.
	Hz	%	%	%
12	600	1	2	7
13	650	1	2	6
14	700	1	2	3
15	750	1	2	3
16	800	0,5	2	3
17	850	0,5	2	3
18	900	0,5	2	3
19	950	0,5	2	3
20	1000	0,5	2	2
21	1050	0,5	1	2
22	1100	0,5	1	2
23	1150	0,5	1	2
24	1200	0,5	1	2
25	1250	0,5	1	2
26	1300	0,5	1	1
27	1350	0,5	1	1
28	1400	0,5	1	1
29	1450	0,5	1	1
30	1500	0,5	0,5	1
31	1550	0,5	0,5	1
32	1600	0,5	0,5	1
33	1650	0,5	0,5	0,5
34	1700	0,5	0,5	0,5
35	1750	0,5	0,5	0,5
36	1800	0,5	0,5	0,5
37	1850	0,5	0,5	0,5
38	1900	0,5	0,5	0,5
39	1950	0,5	0,5	0,5
40	2000	0,5	0,5	0,5
41	2050	0,5	0,5	0,5
42	2100	0,5	0,5	0,5
43	2150	0,5	0,5	0,5
44	2200	0,5	0,5	0,5
45	2250	0,5	0,5	0,5

Appendix

		Ik/I1		
k	f	Min.	Typ.	Max.
	Hz	%	%	%
46	2300	0,5	0,5	0,5
47	2350	0,5	0,5	0,5
48	2400	0,5	0,5	0,5
49	2450	0,5	0,5	0,5
50	2500	0,5	0,5	0,5
THD	%	6,45	21,89	74,34
ki		0,06	0,21	0,60

Min. Values in the case of a low degree of mains pollution by other devices

Typ. Values in the case of standard applications in industrial mains

Max. Values in the case of a high degree of mains pollution by other devices

k k = 1: Fundamental wave; k ≥ 2: Harmonics number

I_{L_cont} Maximum input current (mains input continuous current), see technical data of device - Data for Mains Voltage Supply

ki Distortion factor or harmonic content

I_k Harmonic current of the k-th harmonic

I_1 rms value of the 1st harmonic (fundamental wave)

THD Total Harmonic Distortion

Tab. 18-7: Harmonics HMV01.1R

18.3.3 Harmonics on Mains Voltage

The voltage harmonics depend on the structure of the mains, especially on the mains inductance or the mains short-circuit power at the connection point. At different mains and mains connection points, one device can cause different voltage harmonics.

For a normal mains, the harmonics content of the mains voltage when operating drives generally is below 10%. Short-time drops in mains voltage are below 20%.

More precise values can only be calculated with exact knowledge of the mains data (mains topology), such as line inductance and line capacitance related to the connection point.

These values, however, can temporally vary quite strongly, according to the switch status of the mains. The harmonics of the mains voltage thereby change, too.

Rough estimated values of the mains data are not sufficient for pre-calculation of the harmonics, as mainly the resonance points always present in the mains have a strong influence on the harmonics content.

In order to keep the degree of mains voltage harmonics as low as possible, you should, if possible, not connect capacitors or compensation units (capacitor batteries) directly to the mains. If capacitors or compensation units are absolutely required, you should only connect them to the mains via chokes.

18.4 Voltage Pulse for Test According to EN61000

The figure below shows the voltage pulse for defining the impulse withstand voltage according to EN61000.

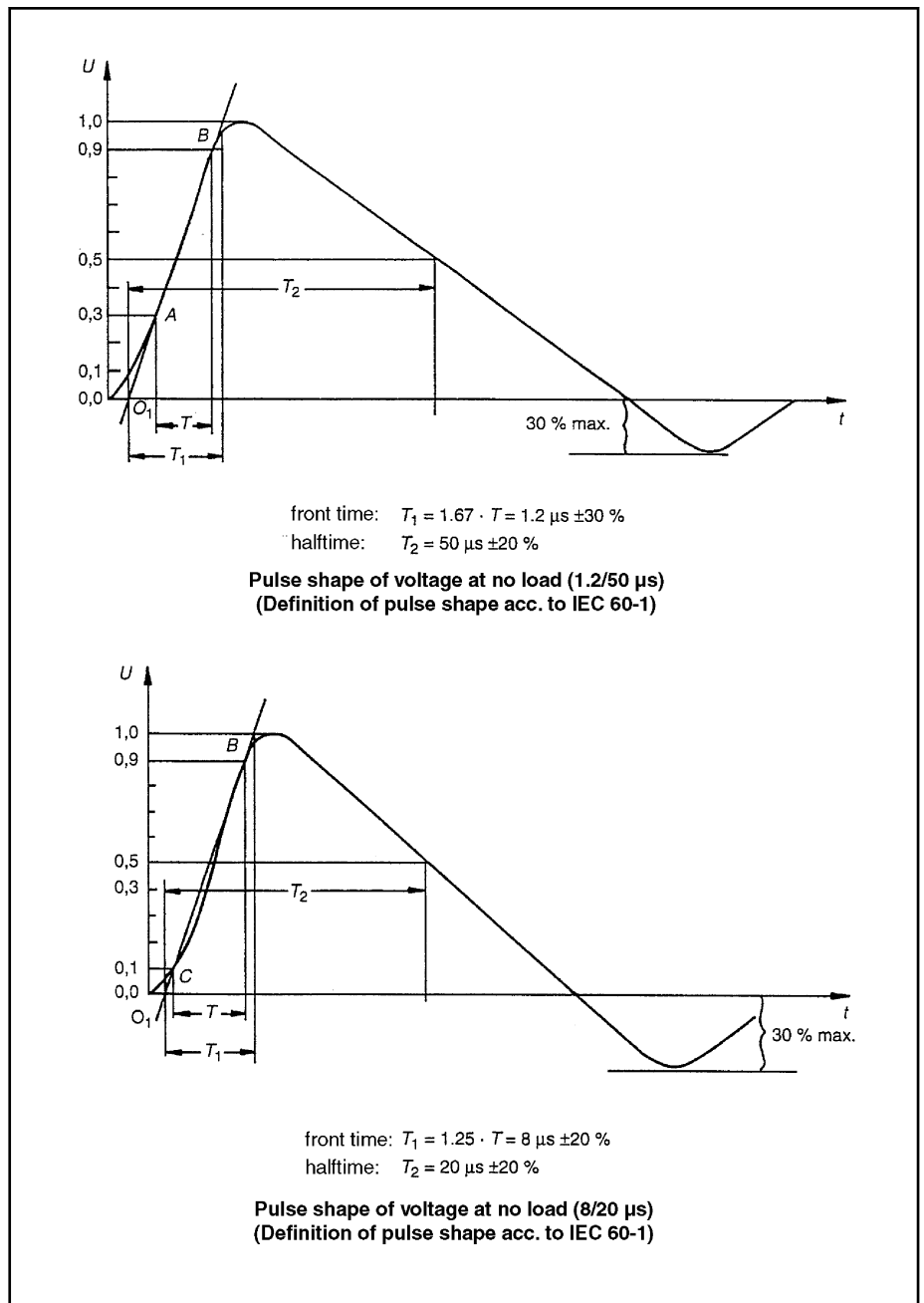

Fig.18-1: Impulse Withstand Voltage 1.2 / 50 μs and 8 / 20 μs According to EN 61000

Appendix

18.5 Discharging of Capacitors

18.5.1 Discharging DC Bus Capacitors

Capacitors as Energy Stores In the drive system Rexroth IndraDrive, capacitors are used in the DC bus as energy stores. In drive controllers and particularly in supply units, such capacitors have already been integrated.

Energy stores maintain their energy even when the supply voltage has been cut off and have to be discharged before somebody gets in contact with them.

If additional capacitors (such as DC bus capacitor units) are connected, these capacitors, too, have to be discharged before somebody gets in contact with them.

Discharge Time Discharging devices have been integrated in the components of the drive system Rexroth IndraDrive; within the indicated discharge time, these devices discharge the voltage below the allowed 50 V.

Due to the operating principle, the discharge time is the longer

- the bigger the energy store (the capacitance value)
- the higher the voltage to which the energy store has been charged
- the greater the resistance for discharging the capacitors

Components of the drive system Rexroth IndraDrive have been dimensioned in such a way that after the supply voltage was cut off, the voltage value falls below 50 V within a discharge time of a maximum of **30 minutes**.

HMV01 and ZKS When using HMV01 supply units (exception: HMV01.1R-W0120), you can take the following measure to shorten the waiting time until the voltage has fallen below 50 V:

Activate the "ZKS" function (ZKS = DC bus short circuit)

Glossary, Definitions of Terms, Abbreviations

Accessories

The accessories are assigned to the corresponding device in order to support its functioning. For example, the basic accessories belong to each drive controller and supply unit to fasten them and connect them electrically.

Additional components

Additional components complement supply units, converters and inverters. Typical additional components are mains chokes, mains filters and braking resistors, for example.

Basic control section circuit board

The basic control section circuit board is the main part of the control section. It has its own interfaces and, in the case of configurable control sections, additional optional slots for optional modules.

Brake chopper

Electronics used to control a braking resistor.

Braking resistor

During deceleration, a braking resistor converts the kinetic energy of a motor into thermal energy. When the response voltage is exceeded, the braking resistor is connected to the DC bus voltage by the brake chopper.

Cable

A cable is a combination of several strands which is kept together by the cable jacket. A typical type of cable is the cable for the motor connection.

Capacitance against housing

Drive controllers and supply units have capacitances against housing C_y which are primarily determined by capacitors at the DC bus (L+, L-). In the drive system, these capacitors form a low-impedance path back to the device for the leakage currents.

Closed-loop (CL)

Closed-loop describes the **closed-loop-controlled** operation of motors, for example with field-oriented control. This operation is possible both in sensorless form and with encoder and is distinguished with regard to its applications.

Sensorless, i.e. without additional encoder, for **velocity** control, for example by means of observer.

With encoder, i.e. with additional encoder, for **velocity** and **position** control of synchronous motors and asynchronous motors in field-oriented operation.

Glossary, Definitions of Terms, Abbreviations

Combination

Combination refers to a combination of components which is formed via a common DC bus or common mains connection. Components such as mains choke, mains transformer and mains filter are used in common.

Common DC bus

Voltage source backed up with powerful capacitors to supply drive controllers with power voltage. "Common" means that the DC bus connections of the involved devices are interconnected.

Configuration

Configuration describes a specific combination of optional modules to form a configured control section which is ideally suited for the intended application.

Connection point of equipment grounding conductor

The connection point of the equipment grounding conductor is the connection point at which the equipment grounding conductor is fixed to the component; the connection point is identified with the symbol .

Control panel

A control panel is a unit for operating a device. A control panel has input and output elements, such as a key panel and a display.

Control section

The control section is a separate component which is plugged into the power section. The control section processes the signals of the connected components (field bus, encoder system, control panel, etc.). Control sections differ with regard to their performance, function and configuration.

Converter, frequency converter

Drive controller which generates three-phase alternating voltage with **variable** amplitude and frequency from the mains voltage with **fixed** amplitude and frequency in order to set the speed of three-phase a.c. motors, for example. Contains the fundamental stages mains rectifier, DC bus and inverter.

Display

The display is part of the control panel for visual output of information.

Drive controller

Device with which a motor can be operated. Umbrella term for converter or inverter.

Electric drive system

An electric drive system is the entirety of interconnected hardware, firmware and software components that have an influence on the sequence of motions of an installation or machine. The electric drive system consists of, for example, supply units, drive controllers, plug-in control units, motors, encoder sys-

Glossary, Definitions of Terms, Abbreviations

tems, as well as auxiliary and additional components (mains filter, mains choke, braking resistors, etc.).

Encoder

Part of an electric drive system which determines the actual value of a value to be controlled.

Equipment grounding conductor

The equipment grounding conductor establishes the conductive connection from the connection point of the equipment grounding conductor of the component to the equipment grounding system.

Equipment grounding system

The equipment grounding system is the entire equipment by which the equipment grounding conductors of components are connected to the equipment grounding conductor of the mains. In the majority of cases, an earth-circuit connector belongs to the equipment grounding system.

FMEA

Failure Mode and Effects Analysis

Hybrid cable

In a hybrid cable, both electrical signals are transmitted on copper wires and optical signals are transmitted on fiber optic cables.

Inverter

Device which generates three-phase alternating voltage with variable amplitude and frequency from the DC bus direct voltage.

Leakage capacitance

The capacitances which generate so-called leakage currents against ground at the outputs of inverters are regarded as leakage capacitance C_{ab} .

The total value of the leakage capacitance is mainly determined by the capacitances in output filters, capacitances of the motor cables (capacitance per unit length against shield and ground wire) and the capacitances of motors (winding capacitance against housing).

Line

A line consists of an electric conductor and its insulation. Sheathed lines are also called cables.

Master communication

Master communication is the specific communication between hierarchical communication levels. By means of master communication, command variables (e.g., command values) are transmitted from a higher-level control unit to receivers, and actual values, for example, are transmitted back to the control unit.

Glossary, Definitions of Terms, Abbreviations

Open-loop (OL)

Open-loop describes the **open-loop-controlled** operation of asynchronous motors at frequency converters in **V/Hz [U/f] operation** without encoder at the motor. This is the simplest operation of asynchronous motors.

Optional module

By means of optional modules, configurable control sections are equipped with various functions. For example, there are optional modules for master communications (e.g., SERCOS), encoder evaluations, I/O extensions, safety technologies, control panels and storage media.

Optional slot

Slot in the control section into which an optional module can be plugged. Only configurable control sections have optional slots.

PELV

"Protectiv **Extra Low Voltage**" circuits provide protection against electric shock and according to standard must comply with specific requirements. Among other things, live parts and exposed conductive parts of PELV circuits must be separated from the primary circuit by means of double or reinforced insulation.

Power section

The power section is a separate component which contains all the important power elements of the drive controller. Power section and control section form a drive controller.

SCCR

Short Circuit Current Ratio

SMPS

Switched Mode Power Supply

Supply unit

Device which provides power supply to drive controllers. For disconnection from the supply mains, it often contains a mains contactor or provides the signals required to control an external mains contactor.

Third-party supply unit

Supply units which do not belong to the "Rexroth IndraDrive" product range.

UPS

An uninterruptible **power supply** is used to ensure the supply of electric loads in the case of disturbances in the power network.

V/Hz [U/f] operation

Operation in which the drive controller generates variable voltage and frequency in order to set the speed of three-phase a.c. motors, for example.

Index

0 ... 9

24V control voltage supply.....	67
24V supply	
Continuous power.....	69
Determining the data for selection.....	67
Installation.....	70
Peak current.....	69
Specification.....	65

A

Abbreviations.....	285
Acceptance tests.....	55
Accessories HAS	
Brief description.....	52
Accumulators.....	281
Additional components	
Arrangement.....	202
At the DC Bus.....	120
At the motor output.....	125
For supply units and converters.....	120
Additional documentations.....	29
Additional external capacitors	
Calculations.....	252
Ambient conditions.....	58
ANAX.....	136
Applications	
Drive system Rexroth IndraDrive.....	47
Appropriate use.....	35
Applications.....	35
Approvals.....	55
Arrangement	
Performance-dependent.....	202

B

Batteries.....	281
Bb contact	
Circuit.....	141
Configuration Rel 1.....	145
Properties.....	142
Bb Contact	
Load capability limits.....	142
Bonding conductor.....	240
Boring dimensions	
For the mounting plate.....	194
Braking resistor	
Continuous power.....	256
Duty cycle.....	257
Duty cycle, relative.....	257
Energy absorption.....	252
Peak power.....	258
Braking resistor HLR01	
Brief description.....	51
Branch	
Fusing.....	266

C

C-UL-US listing.....	55
C-UR-US listing.....	56
Cables	
Capacitance.....	288
Connection cables to motor.....	137
Documentation.....	31
Leakage capacitance.....	288
Calculations.....	247
Additional external capacitors.....	252
Charging the DC bus.....	276
Continuous power in the common DC bus.....	263
Continuous regenerative power.....	255
Control factor.....	258
DC bus continuous power.....	247
DC bus peak power.....	251
Distortion factor.....	261
DPF.....	262
Harmonic content.....	261
Inrush current.....	261
Leakage capacitance.....	272
Mains choke HNL.....	264
Mains connection.....	260
Mains filter: Allowed operating data.....	273
Mains harmonics.....	261
Mains-side phase current.....	260
Peak regenerative power.....	257
Phase current.....	260
Power dissipation.....	252
Power factor $\cos\phi$	262
Power factor $\cos\phi_1$	262
Regenerative power.....	251
Speed characteristic and braking time	
with DC bus short circuit (ZKS).....	277
TPF (λ).....	262
Wattless power load.....	262
Capacitance	
Against housing C_y	113
Capacitance per unit length (motor power	
cable).....	139
Motors.....	287
Power cables.....	288
Capacitors	
Discharging.....	296
CCC, China Compulsory Certification.....	57
CDB	
Brief description.....	49
CDB control section	
Usage.....	50
CE label.....	55
Central supply	
HCS.....	99
HMV.....	96
Certifications.....	55
Changes	

Index

Documentation.....	28	Connection cables	
Characteristic		To motor.....	137
Fuses.....	271	Connection lines	
Charging resistance		Minimum requirements.....	229
HCS02.....	276	Connections	
HCS03.....	277	In the drive system.....	221
Charging the DC bus		Contactors	
Calculations.....	276	Selecting.....	265
China Compulsory Certification (CCC).....	57	Contained substances	
Circuit		see "Significant components".....	281
Deceleration in the case of disturbed		Continuous powers in the common DC bus	
electronic system of drive (DC bus short		Calculations.....	263
circuit is activated).....	155	Continuous regenerative power	
Deceleration in the case of emergency		Calculations.....	255
stop or mains failure.....	166	Control	
For mains connection of		By emergency stop relay.....	169
Rexroth IndraDrive C drive controllers.....	145	External mains contactor for HCS02 and	
For mains connection of		HCS03.....	145
Rexroth IndraDrive M supply units.....	154	Control cabinet	
For mains connection; HCS02 with DC		Area A, interference-free.....	207
bus resistor unit HLB01.1C.....	148	Area B, interference-susceptible.....	209
For mains connection; HCS03 with DC		Area C, strongly interference-susceptible....	209
bus resistor unit HLB01.1D.....	148	Arranging the components.....	189
For the mains connection.....	141	Avoiding moisture condensation.....	217
Circulation.....	193	Cooling.....	215
Combination		Cooling unit.....	216
Firmware, control section, power section....	126	Design.....	215
With components of the control range		Interference areas.....	205
Rexroth IndraControl V.....	136	Multiple-line arrangement of drive con-	
With motor filters HMF01.....	126	trollers.....	218
Commutation dips.....	74	Control circuit	
Compatibility		Deceleration in the case of disturbed	
With foreign matters.....	63	electronic system of drive (DC bus short	
Components		circuit is activated).....	155
Arranging the components in the control		Deceleration in the case of emergency	
cabinet.....	189	stop or mains failure.....	166
Documentations.....	29	For mains connection of	
Main dimensions of the system compo-		Rexroth IndraDrive C drive controllers.....	145
nents.....	189	For mains connection of	
Mounting positions.....	62	Rexroth IndraDrive M supply units.....	154
Performance-dependent arrangement.....	202	For mains connection; HCS02 with DC	
Short designations.....	285	bus resistor unit HLB01.1C.....	148
Conditions		For mains connection; HCS03 with DC	
Ambient and operating conditions.....	58	bus resistor unit HLB01.1D.....	148
Configuration Rel 1 as Bb contact.....	145	For the mains connection.....	141
Connected load		HCS02 converter and HLB01.1C.....	149
Mains, maximum.....	82	HCS02 converter and HLB01.1C and	
Connection		emergency stop relay.....	151
Control voltage.....	232	HCS03 converter.....	153
Control voltage connections.....	232	Parallel operation.....	155
DC bus.....	228	Control circuit position-controlled shutdown	
DC bus connections.....	228	HMV01.1R supply unit with integrated	
Equipment grounding conductor.....	223	mains contactor.....	168
Ground connection.....	222	Control circuit with DC bus short circuit (ZKS)	
Mains choke.....	226	HMV01.1R-W0120 supply unit with exter-	
Module bus.....	235	nal mains contactor.....	165
Motor.....	236	Supply unit HMV01.1E with integrated	
Motor and drive controller.....	236	mains contactor.....	159

Supply unit HMV01.1R with integrated mains contactor.....	161, 163	DC bus peak power	
Control circuit without DC bus short circuit (ZKS)		Calculations.....	251
HMV01.1E supply unit with integrated mains contactor.....	170	DC bus resistor unit	
HMV01.1R supply unit with integrated mains contactor.....	172	HLB01, brief description.....	51
HMV01.1R supply unit without integrated mains contactor.....	174	DC bus short circuit (ZKS)	
HMV02.1R supply unit with integrated mains contactor.....	176	Calculating speed characteristic and braking time.....	277
Control factor		DC bus short circuit ZKS.....	155
Calculations.....	258	Deceleration	
Control section		In the case of disturbed electronic system of drive (DC bus short circuit is activated)...	155
In drive controller.....	25	In the case of emergency stop; control circuit.....	166
Control sections		In the case of mains failure; control circuit...	166
Brief description.....	49	Declaration of conformity.....	55
Control voltage		Derating vs. installation altitude	
Connection.....	232	Overvoltage limiter.....	60, 61
Specification.....	65	Devices	
Supply with control voltage 24 V.....	67	Mounting positions.....	62
Control voltage supply		Short designations.....	285
Buffering, UPS.....	67	Dimensioning	
Loop-through contacts.....	71	Line cross sections and fuses.....	266
Convection.....	193	Dimensions	
Cooling system		Main dimensions of the system components.....	189
Project planning.....	215	Discharging	
Cooling unit		DC bus capacitors.....	296
Arrangement.....	216	Disposal.....	281
Corner-grounded delta mains.....	79	Distance	
CSB		Between the devices.....	190
Brief description.....	49	Lateral.....	193
CSB control section		To the bottom of the devices.....	191
Usage.....	50	To the top of the devices.....	191
CSE		Distortion factor.....	83, 290
Brief description.....	49	Calculations.....	261
CSE control section		DLT.....	265
Usage.....	50	Brief description.....	47
CSH		Selection.....	265
Brief description.....	49	Documentation	
CSH control section		Cables.....	31
Usage.....	50	Changes.....	28
Cy		Drive systems.....	29
Capacitance against housing.....	113	Firmware.....	31
D		Motors.....	30
Data		Overview.....	29
Ambient conditions.....	58	Purpose.....	28
Operating conditions.....	58	Reference documentations.....	29
DC bus		System components.....	29
Connection.....	228	DPF	
DC bus capacitor unit HLC01		Calculations.....	262
Brief description.....	52	Drive controller	
DC bus capacitors		Basic design.....	24
Discharging.....	296	Control section.....	25
DC bus continuous power		Determine appropriate drive controller.....	247
Calculations.....	247	HCS02, brief description.....	50
		HCS03, brief description.....	50
		HMD01, brief description.....	49
		HMS01, brief description.....	49

Index

HMS02, brief description.....	49	File numbers	
Power section.....	24	UL.....	55
Drive controllers		Firmware	
Multiple-line arrangement.....	218	Documentation.....	31
Drive system.....	37	KMS01.....	132
Combination of components.....	93	KMS02.....	132
Configuration.....	93	KSM01.....	132
Connections.....	221	KSM02.....	132
Rexroth IndraDrive C.....	12	Firmware version	
Rexroth IndraDrive M.....	14	Converter HCS01.....	130
Rexroth IndraDrive Mi.....	17	Converters HCS02, HCS03, HCS04.....	131
Drive system Rexroth IndraDrive		HCQ02.....	132
Applications.....	47	IndraDrive Mi.....	132
DST		Inverters HMS01, HMS02, HMD01.....	128
Brief description.....	47	KMS01.....	132
Duty cycle ED		KMS02.....	132
Relative.....	257	KSM01.....	132
		KSM02.....	132
E		Required for control section.....	127
Electric drive system.....	37	Required for motor.....	133
Electromagnetic compatibility (EMC).....	181	Required for power section.....	128
EMC		FNN2	
Declaration of EMC conformity.....	186	Supply unit.....	97
Electromagnetic compatibility.....	181	Foreign matters	
Ensuring the requirements.....	186	Compatibility.....	63
Filtering.....	187	Functions.....	28
Grounding.....	187	Fuses	
Limit values for line-based disturbances.....	183	Characteristic.....	271
Measures for design and installation.....	203	Circuit breaker.....	271
Measures to reduce noise emission.....	187	Design.....	271
Noise emission of the drive system.....	182	Dimensioning.....	266
Noise immunity.....	181	Fusing	
Requirements.....	181	And mains contactor.....	265
Shielding.....	187	Selecting.....	265
Emergency stop relay		G	
Control without DC bus short circuit (ZKS)..	169	G1, G2, G3, G4, G5	
EMI		Mounting positions.....	62
Electromagnetic interference.....	181	Glossary.....	IX
Encoder		Ground connection	
Cables.....	140	Of Housing.....	222
Optional module encoder evaluation.....	133	Ground connections.....	211
EnDat		H	
Encoder evaluation.....	133	HAB01	
Environmental protection.....	281	Brief description.....	52
ePlan macros.....	240	HAC01	
Equipment grounding conductor		Brief description.....	52
Connection.....	89, 223	Hall sensor box SHL	
Connections.....	223	Brief description.....	52
Cross section.....	225	Encoder evaluation.....	133
External wiring.....	271	Harmonic content.....	290
		Calculations.....	261
F		Harmonics	
Fan unit HAB01		Emitted.....	290
Brief description.....	52	Mains current.....	290
Field wiring.....	271	Mains voltage.....	294
Fields of application			
Drive system Rexroth IndraDrive.....	47		

HAS		Brief description.....	47
Brief description.....	52	Housing for control sections HAC01	
HAS02		Brief description.....	52
Shield connection with accessory HAS02....	237	I	
HAS04		Impulse withstand voltage.....	294
Use.....	113	Inappropriate use.....	36
Hazardous substances.....	281	Consequences, exclusion of liability.....	35
HCS		IndraDyn H.....	140
Central supply.....	99	Inductance per unit length.....	139
Parallel operation.....	104	Industrial sectors.....	47
Supply unit.....	99	Inrush current	
HCS02		Calculations.....	261
Brief description.....	50	Installation	
Supply unit for HMS/HMD.....	101	EMC measures.....	203
Supply unit for KCU and KSM/KMS.....	101	Ground connections.....	211
HCS03		Signal lines.....	212
Brief description.....	50	Installation conditions.....	58
Supply unit for HMS01/HMD01.....	102	Installation methods.....	272
Hierarchical levels		Installation type	
Rexroth IndraDrive.....	11	B1.....	267, 270
HIPERFACE.....	133	B2.....	268, 270
HLB		E.....	269, 270
Selection aid.....	122	NFPA.....	270
HLB01		UL508A.....	270
Brief description.....	51	Insulation monitoring.....	66
HLC01		Insulation monitoring devices.....	92
Brief description.....	52	Insulation resistance test.....	64
HLR		Internal wiring.....	271
Selection aid.....	122	ISCCR	
HLR01		Short-circuit current ratio.....	80
Brief description.....	51	Isolating transformer	
For HCS02.....	124	DLT.....	265
For HCS03.....	124	IT mains type.....	77
HMD01		K	
Brief description.....	49	k	
HMF01		Distortion factor.....	290
Motor filter, assignment.....	126	KCU02	
Motor filter, brief description.....	52	Supplied by HCS02.....	101
HMS01		L	
Brief description.....	49	Leakage capacitance.....	299
HMS02		Calculations.....	272
Brief description.....	49	Determining.....	272
HMV		Motors.....	287
Central supply.....	96	Power cables.....	288
HMV01		Leakage currents	
Brief description.....	49	Cause.....	90
HMV02		Limit values	
Brief description.....	49	For line-based disturbances.....	183
HNF		For noise immunity.....	182
Brief description.....	47	Line	
HNF01		Correction factor.....	271
HAS04 required.....	113	Cross sections, dimensioning.....	266
Minimum capacitance.....	113	Fuses, dimensioning.....	266
HNK		Listing	
Brief description.....	47		
HNL			
Brief description.....	48		
HNS02			

Index

C-UL-US.....	55	Calculations.....	261
C-UR-US.....	56	Emitted.....	290
M		Mains overvoltages	
Mains		Maximum allowed.....	75
Grounded via outer conductor.....	79	Mains short circuit	
Maximum connected load.....	82	Mains short circuit ratio.....	82
Measures for compliance with allowed		Mains short-circuit current.....	80
THD or distortion factor.....	83	Mains short-circuit power.....	80
Selecting mains connection components.....	84	Mains transformer	
Mains choke		Selection.....	265
Brief description.....	48	Mains transformers	
Connection.....	226	Brief description.....	47
Determining.....	264	Mains types.....	76
Selection.....	264	Mains voltage	
Mains circuit breaker		Harmonics.....	294
Selecting.....	265	Mains voltage unbalance.....	262
Mains classes.....	80	Mains-side phase current	
Mains connection		Calculating.....	260
Calculations.....	260	Master-slave.....	155
Circuit.....	141	Measures of radio interference suppression	
Circuit for Rexroth IndraDrive C drive		For relays, contactors, switches, chokes,	
controllers.....	145	inductive loads.....	212
Circuit for Rexroth IndraDrive M drive		Minimum capacitance	
controllers.....	154	At the DC bus.....	113
Control circuit.....	141	Use of HNF01.....	113
Control circuit for Rexroth IndraDrive C		Minimum inductance.....	81
drive controllers.....	145	Module bus	
Control circuit for Rexroth IndraDrive M		Connection.....	235
drive controllers.....	154	Moisture condensation	
HCS converters.....	113	Avoiding.....	217
HMV supply units.....	109	Motor	
Mains connected load.....	81	Capacitance.....	287
Project planning.....	73	Connection.....	236
Protection systems.....	84	Documentation.....	30
Requirements.....	73	Encoder evaluation.....	133
Transformer, mains filter, mains choke.....	106	IndraDyn H.....	140
With HNL mains chokes, HNF mains fil-		Leakage capacitance.....	287
ters and HNK mains chokes.....	106	Third-party motors.....	241
Mains contactor		Motor cable	
Additional.....	144	Allowed length.....	138
And Fusing.....	265	Connection at drive controller.....	236
Circuit.....	141	Power cable selection.....	138
Control of external mains contactor for		Motor cables	
HCS02 und HCS03.....	145	Capacitance per unit length.....	139
Redundant.....	144	Connected in parallel.....	139
Selecting.....	265	Inductance per unit length.....	139
Suppressor circuit.....	143	Selection of encoder cables.....	140
Mains filter		Unshielded.....	139
Brief description.....	47	Motor cables connected in parallel.....	139
Connection.....	226	Motor fan	
Determining.....	264	Mains filter.....	208
Motor fan.....	208	Motor filter HMF01	
Operating data, allowed.....	273	Assignment to HCS.....	126
Other loads.....	208	Brief description.....	52
Selection.....	264	With IndraDyn.....	126
Mains harmonics.....	74	Motor holding brake	
		Voltage drop.....	139
		Motor output	

Additional components.....	125	Power consumption	
Motor paint coat		Maximum.....	69
Additional paint coat.....	64	Typical.....	69
Mounting		Power dissipation	
Boring dimensions for the mounting plate....	194	Calculations.....	252
Mounting position		Power factor $\cos\phi$	
Definition (G1, G2, G3, G4, G5).....	62	Calculations.....	262
IM B5.....	63	Power factor $\cos\phi_1$	
IM V1.....	63	Calculations.....	262
IM V3.....	63	Power factors.....	290
Motor-integrated servo drive.....	63	Power supply	
Multiple-line arrangement of drive controllers...	218	Switching off.....	143
		Switching on.....	143
N		Power voltage	
NFD		Power voltage supply.....	73
Brief description.....	47	Production processes.....	281
NFE		Products	
Brief description.....	47	Short designations.....	285
Noise emission		Project planning	
Measures for reduction.....	187	Of cooling system.....	215
Of the drive system.....	182	Project Planning Manuals.....	29
Noise immunity		Protection systems	
Limit values.....	182	At the mains connection.....	84
Noise immunity in the drive system.....	181	Protective extra-low voltage.....	41
Number of axes		Protective grounding.....	85
At HMV01.....	111		
At HMV02.....	112	R	
Capacitance against housing C_y	95	RCCB.....	89
HCS02.....	114	RCD.....	89
HCS03.....	117	RD500	
Orientation guide.....	95	Supply unit.....	105
		Recycling.....	281
O		Reference documentations.....	29
Operating conditions.....	58	Regenerative power	
Operation at partial load.....	260, 266	Calculations.....	251
Operation under rated conditions.....	266	Rel 1	
Operator terminals		Configuration as Bb contact.....	145
VCP.....	136	Residual-current-operated circuit breakers.....	89
Overvoltage limitation		Resolver.....	133
Note on project planning.....	75	Return of products.....	281
Overvoltage limiter		Rexroth IndraDrive	
Derating vs. installation altitude.....	60, 61	Hierarchical levels.....	11
Overvoltage limiters.....	75	System platform.....	11
		System presentation.....	11
P		Rexroth IndraDrive C	
Packaging.....	281	Drive system.....	12
Parallel operation		Rexroth IndraDrive M	
HCS02 with HCS02.....	102	Drive system.....	14
HCS03 with HCS03.....	102	Rexroth IndraDrive Mi	
HMV.....	98	Drive system.....	17
HMV01, control circuit.....	155		
Number of components HCS.....	104	S	
Peak regenerative power		Safety instructions for electric drives and	
Calculations.....	257	controls.....	37
PELV.....	41	Selection aid	
Phase current		HLB.....	122
Calculating.....	260	HLR.....	122

Index	
sercos analog converter.....	136
Shield connection	
Motor cable.....	236
SHL	
Brief description.....	52
Hall sensor box.....	133
Short designations.....	285
Short-circuit current	
Symmetrical.....	80
Short-time interruptions.....	74
Signal lines	
Installation.....	212
Signal sequence	
When switching on and off.....	177
Significant components.....	281
Simultaneity factor.....	249
Smart Energy Mode	
Supply unit.....	97
Specifications	
Of the components.....	55
Standard motors	
Voltage load.....	126
State-of-the-art.....	35
Storage	
Of the components.....	58
Supply	
With control voltage 24 V.....	67
With mains voltage.....	73
With power voltage.....	73
Supply unit	
FNN2 design.....	97
HMV01, brief description.....	49
HMV02, brief description.....	49
Smart Energy Mode.....	97
Support	
See service hotline.....	283
Switching off	
Power supply.....	143
Signal sequence.....	177
Switching on	
Power supply.....	143
Signal sequence.....	177
System connections.....	221
Position.....	222
System elements	
Product overview.....	285
Short designations.....	285
System impedance.....	80
System platform.....	11
System presentation.....	11
T	
Test	
Factory-side.....	64
Insulation resistance.....	64
Voltage test.....	64
THD.....	83, 261, 290
Third-party motors	
At drive controllers.....	241
Third-party supply units.....	105
Time behaviour	
When switching on and off.....	177
TN-C mains type.....	76
TN-S mains type.....	76
Total Harmonic Distortion (THD).....	261
TPF (λ)	
Calculations.....	262
Transport	
Of the components.....	57
TT system.....	78
Type current.....	26
Type of supply	
For power sections.....	93
Type performance.....	26
U	
UL	
File numbers.....	55
Listing.....	55, 56
Requirement SCCR.....	80
Ungrounded mains.....	77
UPS	
Control voltage supply.....	67
Use	
Appropriate use.....	35
Inappropriate use.....	36
V	
VCP	
Operator terminals.....	136
Voltage dips.....	74
Voltage drop	
Connection to motor holding brake.....	139
Voltage pulse.....	294
Voltage test.....	64
W	
Wattless power load	
Calculations.....	262
Z	
ZKS	
DC bus short circuit.....	155

Notes

Bosch Rexroth AG
Electric Drives and Controls
P.O. Box 13 57
97803 Lohr, Germany
Bgm.-Dr.-Nebel-Str. 2
97816 Lohr, Germany
Tel. +49 9352 18 0
Fax +49 9352 18 8400
www.boschrexroth.com/electrics



R911309636

DOK-INDRV*-SYSTEM*****-PR06-EN-P