

# Rexroth MKE Synchronous Motors for Potentially Explosive Areas acc. to ATEX and UL/CSA

R911297663  
Edition 06

Project Planning Manual



**Title** Rexroth MKE Synchronous Motors  
for Potentially Explosive Areas  
acc. to ATEX and UL/CSA

**Type of Documentation** Project Planning Manual

**Document Typecode** DOK-MOTOR\*-MKE\*GEN2\*\*\*-PR06-EN-P

**Internal File Reference** RS-e18d46620a6846ac01e65e1ec364402b-3-en-US-9

**Record of Revision**

Edition	Release Date	Notes
DOK-MOTOR*-MKE*GEN2***-PR01-EN-P	06/2003	First edition
DOK-MOTOR*-MKE*GEN2***-PR02-EN-P	02/2004	Revision
DOK-MOTOR*-MKE*GEN2***-PR03-EN-P	03/2004	Revision
DOK-MOTOR*-MKE*GEN2***-PR04-EN-P	08/2007	Introduction IndraDrive Encoder, revision
DOK-MOTOR*-MKE*GEN2***-PR05-EN-P	11/2010	Standards EN 60079 ff.
DOK-MOTOR*-MKE*GEN2***-PR06-EN-P	07/2012	Standards EN 60079:2009.

**Copyright** © Bosch Rexroth AG 2012

Copying this document, giving it to others and the use or communication of the contents thereof without express authority, are forbidden. Offenders are liable for the payment of damages. All rights are reserved in the event of the grant of a patent or the registration of a utility model or design (DIN 34-1).

**Validity** The specified data is for product description purposes only and may not be deemed to be guaranteed unless expressly confirmed in the contract. All rights are reserved with respect to the content of this documentation and the availability of the product.

**Published by** Bosch Rexroth AG  
Electric Drives and Controls  
Bgm.-Dr.-Nebel-Str. 2 ■ 97816 Lohr a. Main, Germany  
Phone +49 9352 18 0 ■ Fax +49 9352 18 8400  
<http://www.boschrexroth.com/electrics>  
Dept. DC-IA/EDM3 (jw/mb)

**Note** This document has been printed on chlorine-free bleached paper.

# Table of Contents

	Page
<b>1 Introduction to the Product.....</b>	<b>5</b>
1.1 MKE.....	5
1.1.1 General Information.....	5
1.1.2 Design.....	7
1.2 About this Documentation.....	8
<b>2 Important Instructions on Use .....</b>	<b>11</b>
2.1 Intended Use .....	11
2.1.1 Introduction.....	11
2.1.2 Areas of Use and Application.....	11
2.2 Inappropriate Use.....	12
<b>3 Safety Instructions for Electric Drives and Controls.....</b>	<b>13</b>
3.1 Definitions of Terms.....	13
3.2 General Information.....	14
3.2.1 Using the Safety Instructions and Passing Them on to Others.....	14
3.2.2 Requirements for Safe Use.....	14
3.2.3 Hazards by Improper Use.....	15
3.3 Instructions with Regard to Specific Dangers.....	16
3.3.1 Protection Against Contact With Electrical Parts and Housings.....	16
3.3.2 Protective Extra-Low Voltage as Protection Against Electric Shock .....	17
3.3.3 Protection Against Dangerous Movements.....	18
3.3.4 Protection Against Magnetic and Electromagnetic Fields During Operation and Mounting.....	19
3.3.5 Protection Against Contact With Hot Parts.....	20
3.3.6 Protection During Handling and Mounting.....	20
3.3.7 Battery Safety.....	20
3.3.8 Protection Against Pressurized Systems.....	21
3.4 Explanation of Signal Words and the Safety Alert Symbol.....	21
<b>4 Technical Data .....</b>	<b>23</b>
4.1 Characteristics.....	23
4.1.1 General Information.....	23
4.1.2 Operating Modes.....	23
4.1.3 Duty Cycle.....	23
4.1.4 Definition of Parameters.....	24
4.2 UL File Number.....	27
4.3 Technical Data Encoder for MKE Motors.....	28
4.4 Technical Data Holding Brakes.....	29
4.5 MKE037B Technical Data.....	30
4.6 MKE047B Technical Data.....	32
4.7 MKE098B Technical Data.....	34
4.8 MKE118B Technical Data.....	38
4.9 MKE118D Technical Data.....	42

## Table of Contents

	Page
<b>5 Specifications</b> .....	<b>47</b>
5.1 MKE037 Specifications.....	47
5.2 MKE047 Specifications.....	50
5.3 MKE098 Specifications.....	53
5.4 MKE118 Specifications.....	56
<b>6 Type Codes</b> .....	<b>59</b>
6.1 Description.....	59
6.2 MKE037.....	61
6.3 MKE047.....	62
6.4 MKE098.....	63
6.5 MKE118.....	64
<b>7 Accessories and Options</b> .....	<b>65</b>
7.1 Motor Encoder.....	65
7.2 Holding Brakes.....	66
7.3 Gearboxes.....	67
<b>8 Connection Technique</b> .....	<b>69</b>
8.1 Variants.....	69
8.2 Motor Connection According to European Standard (EN).....	72
8.3 Connection According to American Standard (UL).....	73
<b>9 Operating Conditions and Application Notes</b> .....	<b>75</b>
9.1 Permitted Areas of Use for MKE Motors.....	75
9.1.1 Motors with Housing Design "E".....	75
9.1.2 Application Conditions ATEX Device Group II, Category 2.....	76
9.1.3 Motors with Housing Design "U",.....	78
9.2 Installation Altitude and Ambient Temperature.....	79
9.3 Degree of Protection.....	79
9.4 Compatibility with Foreign Materials.....	79
9.5 Design and Installation Positions.....	80
9.6 Motor Paint.....	80
9.7 Vibration.....	80
9.8 Shock.....	81
9.9 Output Shaft.....	81
9.9.1 Plain Shaft.....	81
9.9.2 Output Shaft with Keyway.....	81
9.9.3 Output Shaft with Shaft Sealing Ring.....	82
9.10 Bearings and Shaft Load.....	84
9.10.1 Radial Load, Axial Load.....	84
9.10.2 Shaft Load MKE Motors.....	86
9.10.3 Bearing Lifetime.....	88
9.11 Attaching Drive Elements.....	89

## Table of Contents

	Page
9.12	Holding Brakes (Ex)..... 90
9.12.1	Holding Brake Electrically-Released..... 90
9.12.2	Holding Brakes - Notes Regarding Safety..... 90
9.12.3	System Safety for Holding Brakes ..... 91
9.12.4	Layout of Holding Brakes..... 92
9.12.5	Holding Brake–Commissioning and Maintenance Instructions ..... 92
<b>10</b>	<b>Transport and Storage..... 95</b>
10.1	Transport Instructions..... 95
10.2	Storage Instructions..... 97
10.2.1	Storage Conditions..... 97
10.2.2	Storage Times..... 98
<b>11</b>	<b>Delivery Status, Identification, Handling..... 99</b>
11.1	State of Delivery..... 99
11.1.1	General Information..... 99
11.1.2	Inspection at the Factory..... 99
11.1.3	Test Realized by the Customer..... 99
11.2	Identification ..... 100
11.2.1	Scope of Delivery..... 100
11.2.2	Rating Plate..... 100
11.3	Handling..... 103
<b>12</b>	<b>Installation..... 105</b>
12.1	Safety..... 105
12.2	Skilled Personnel..... 106
12.3	Mechanical Mounting – Motor Assembly..... 107
12.3.1	Flange Assembly..... 107
12.3.2	Preparation..... 107
12.3.3	Assembly..... 108
12.4	Electrical Connection..... 109
12.4.1	Safety Instructions..... 109
12.4.2	Electric Connection MKE037, MKE047, MKE098 Housing Design "E" ..... 109
12.4.3	Electric Connection MKE118 Housing Design "E" ..... 112
12.4.4	Electric Connection Motor Types MKE037 ... 098 Housing Design "U"..... 117
12.4.5	Electric Connection MKE118 Housing Design "U"..... 118
<b>13</b>	<b>Commissioning, Operation and Maintenance ..... 119</b>
13.1	Commissioning..... 119
13.2	Operation..... 120
13.3	Maintenance / Dismantling / Repair..... 121
13.3.1	Dismantling..... 121
13.3.2	Maintenance / Repair..... 122

## Table of Contents

	Page
<b>14 Environmental Protection and Disposal .....</b>	<b>123</b>
14.1 Environmental Protection.....	123
14.2 Disposal.....	123
<b>15 Appendix.....</b>	<b>125</b>
15.1 List of Standards.....	125
15.2 Selection of Connection Cable.....	127
15.2.1 Power Cable IndraDyn S MKE.....	127
15.2.2 Encoder cable IndraDyn S MKE.....	128
15.3 Declaration of Conformity .....	129
<b>16 Service and Support.....</b>	<b>131</b>
<b>Index.....</b>	<b>133</b>

# 1 Introduction to the Product

## 1.1 MKE

### 1.1.1 General Information

The MKE servo motors fulfill the specifications according to ATEX and UL/CSA in one class. This permits the worldwide use of Rexroth MKE motors with one machine design only.

In connection with the drive devices of Rexroth, the MKE motors generates drive systems with high functionality for the use in hazardous areas.

**Performance list** MKE motors are available in the following power spectrum:

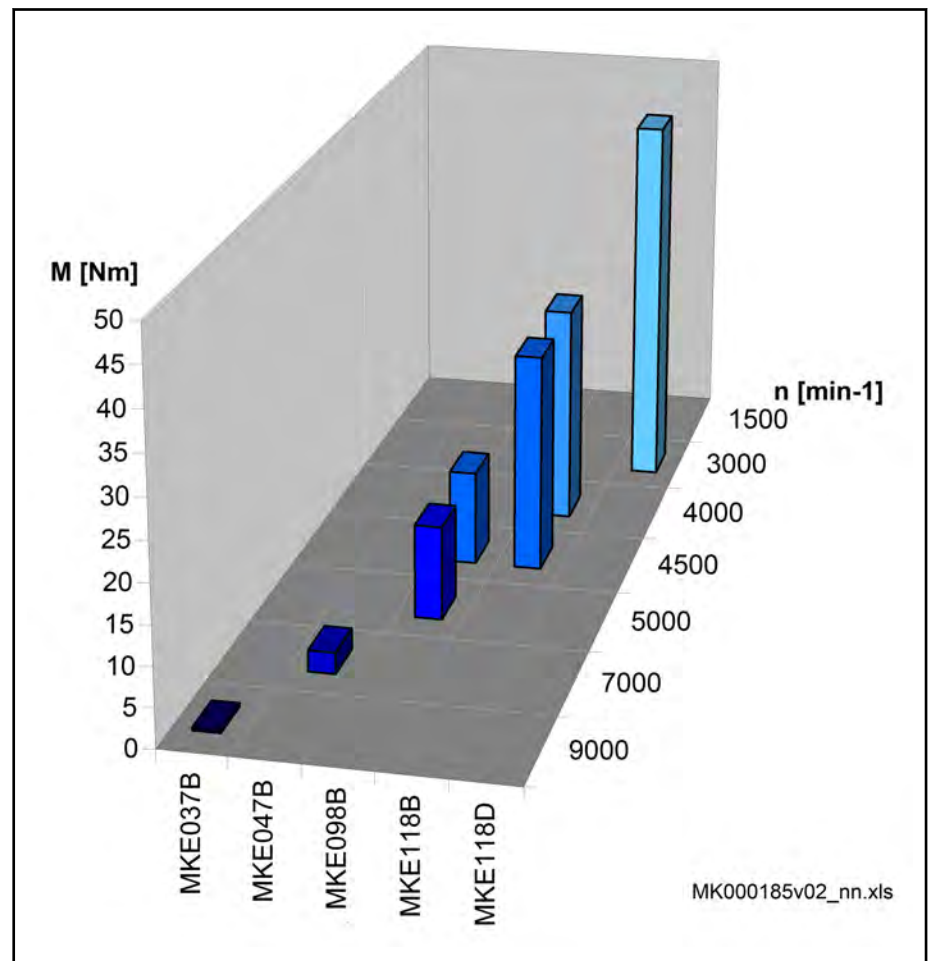

Fig. 1-1: MKE power graduation

**Performance feature** MKE motors are characterized by the following advantages:

- Motor design according to EN 60079-0, EN 60079-1, EN 60079-31
- High operational reliability
- Maintenance-free operation (owing to the brushless design and use of bearings grease-lubricated for their entire lifetime)
- Use under adverse environmental conditions is possible (owing to the completely closed motor design in IP 65 degree of protection)
- Overload protection (by means of motor-temperature control)
- High performance data

## Introduction to the Product

- High dynamics (owing to the favorable ratio of torque to inertia mass)
- High overload capability (owing to the favorable heat dissipation from the stator windings to the outside wall of the motor housing)
- Peak torque utilizable across a wide speed range (owing to electronic commutation)
- Continuous start-stop operation possible with high repeat frequencies (owing to electrical commutation)
- Easy attachment to the machine (owing to flange according to DIN 42948)
- Any installation position desired
- Simple and fast startup (by data memory)

## Design and Components

MKE motors are permanent-magnet motors with electronic commutation. Special magnet materials permit the motors to be designed with low inertia masses. The following figure shows the principal design of MKE motors.

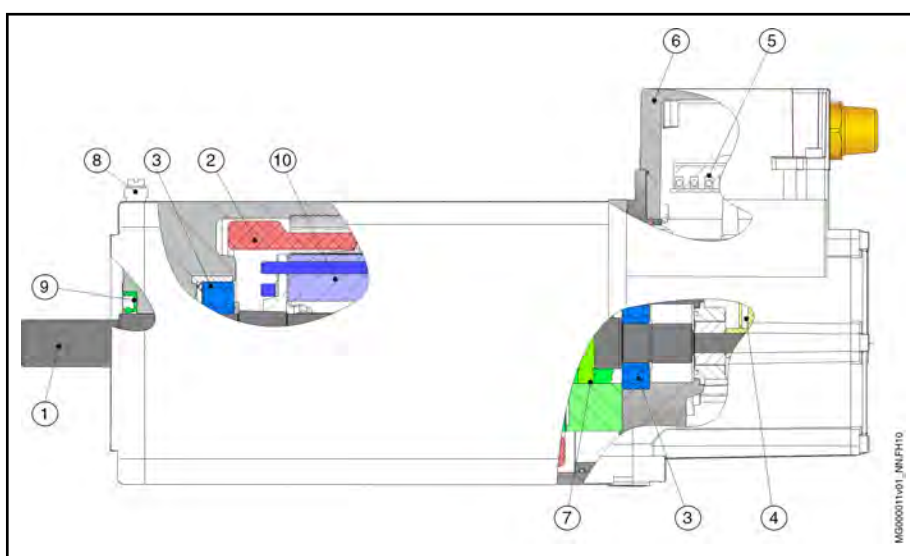

- |      |                              |
|------|------------------------------|
| (1)  | Drive shaft                  |
| (2)  | Stator with winding          |
| (3)  | Bearings                     |
| (4)  | Motor encoder                |
| (5)  | Connection unit              |
| (6)  | Terminal box lid             |
| (7)  | Holding brake (optional)     |
| (8)  | Grounding clamp              |
| (9)  | Shaft sealing ring           |
| (10) | Rotor with permanent magnets |

Fig. 1-2: Design of MKE motors



## 1.1.2 Design

MKE motors are available in various designs. Conditional upon existing national regulations and standards, the MKE motors have to be differentiated from the housing according to:

- Design "**E**" acc. to European Standard (EU with cURus conform insulation system)
- Design "**U**" according to American Standard (UL)

unterteilt werden.

The connection technology of the MKE motors is variously processed according to the national regulations.



Please heed the notes according to the valid national regulations in the chapter "Application Notes".

---

## Introduction to the Product

## 1.2 About this Documentation

### Storage



This documentation must be kept by the user during the whole period of use and lifetime of the product and be passed on in case of sale.

Save these instructions.

### Structure of this document edition

The present documentation contains safety regulations, technical data, and operating instructions for MKE motors. The individual chapters can be subdivided into the following focal points:

Chapter	Title	Content
1	Introduction to the Product	General Information
2	Important Instructions on Use	Safety
3	Safety Instructions	
4	Technical Data	Product Description (for planners and designers)
5	Specifications	
6	Type Codes	
7	Accessories and Options	
8	Connection Technique	
9	Operating Conditions and Application Notes	
10	Transport and Storage	Practice (for operating and maintenance personnel)
11	Delivery Status, Identification, Handling	
12	Installation	
13	Commissioning, Operation and Maintenance	General Information
14	Environmental Protection and Disposal	
15	Appendix	
16	Service & Support	
	Index	

Fig. 1-3: Document Structure

### Additional documentation

You might need additional documentation referring to the used devices to project the drive systems of the MKE motor unit. Rexroth provides the entire product documentation in the Bosch Rexroth media directory (in PDF format) under <http://www.boschrexroth.com/various/utilities/mediadirectory/index.jsp>.

### Standards

This documentation refers to German, European and international technical standards. Documents and sheets on standards are subject to copyright protection and may not be passed on to third parties by Rexroth. If need be, please contact the authorized sales outlets or, in Germany, directly:

BEUTH Verlag GmbH

Burggrafenstrasse 6

10787 Berlin, Germany

Phone +49-(0)30-26 01-22 60, Fax +49-(0)30-26 01-12 60

Internet: <http://www.din.de/beuth>

Email: [postmaster@beuth.de](mailto:postmaster@beuth.de)

### External systems

Documentation for external systems which are connected to Rexroth components are not included in the scope of delivery and must be ordered directly from the respective manufacturers.

### Your feedback

Your experiences are an essential part of the process of improving both the product and the documentation.

## Introduction to the Product

Please do not hesitate to inform us of any mistakes you detect in this documentation or of any modifications you might desire.

Please send your remarks to:

Bosch Rexroth AG

Dept. DC-IA/EDM3

Buergermeister-Dr.-Nebel-Strasse 2

97816 Lohr, Germany

E-mail: [dokusupport@boschrexroth.de](mailto:dokusupport@boschrexroth.de)



## 2 Important Instructions on Use

### 2.1 Intended Use

#### 2.1.1 Introduction

Rexroth products are developed and manufactured according to the state of the art. Before they are delivered, they are inspected to ensure that they operate safely.

#### **WARNING**

**Damage to persons and property due to improper product handling!**

The products are designed for industrial use and must only be used as intended. If they are inappropriately used, situations may arise resulting in injuries to property and persons.



Rexroth, as the manufacturer, does not provide any warranty, assume any liability, or pay any damages for damage caused by products not being used as intended. Any risks resulting from the products not being used as intended are the sole responsibility of the user.

Before using Rexroth products, the following condition precedent must be fulfilled so as to ensure that they are used as intended:

- Everyone who in any way whatsoever handles one of our products must read and understand the corresponding notes regarding safety and regarding the intended use.
- If the products are hardware, they must be kept in their original state, i.e. no constructional modifications must be made. Software products must not be decompiled; their source codes must not be modified.
- Damaged or improperly working products must not be installed or put into operation.
- It must be ensured that the products are installed according to the regulations specified in the documentation.

#### 2.1.2 Areas of Use and Application

Rexroth motors of MKE series are designed to be used as rotary main and servo drive motors. The following are typical fields of application:

- Machine tools
- Printing and paper-processing machines,
- Packaging and food-processing machines,
- Metal-forming machines

Device types with different driving powers and different interfaces are available for an application-specific use of the motors.

Controlling and monitoring of the motors may require connection of additional sensors and actuators.

## Important Instructions on Use



---

MKEmotors must only be used with the accessories specified in this documentation. Components that are not explicitly mentioned must neither be attached nor connected. The same is true for cables and lines.

The operation must only be carried out in the explicitly mentioned configurations and combinations of the component and with the software and firmware specified in the corresponding functional description.

---

Any connected drive control device must be programmed before startup in order to ensure that the motor executes the functions specifically to the particular application.

MKEmotors may only be operated under the assembly, mounting and installation conditions, in the normal position, and under the environmental conditions (temperature, degree of protection, humidity, EMC etc.) specified in this documentation.

## 2.2 Inappropriate Use

Any use of MKE motors outside of the fields of application mentioned above or under operating conditions and technical data other than those specified in this documentation is considered to be "inappropriate use".

MKE motors may not be used if . . .

- Ambient conditions require a higher explosion protection than indicated at the motor type plate.
- They are subject to operating conditions which do not comply with the ambient conditions described above. For example, they must not be operated under water, under extreme temperature fluctuations or extreme maximum temperatures.
- The intended application is not explicitly released by Bosch Rexroth. Please make absolutely sure that the instructions given in the general safety notes are also complied with!

## 3 Safety Instructions for Electric Drives and Controls

### 3.1 Definitions of Terms

<b>Application Documentation</b>	Application documentation comprises the entire documentation used to inform the user of the product about the use and safety-relevant features for configuring, integrating, installing, mounting, commissioning, operating, maintaining, repairing and decommissioning the product. The following terms are also used for this kind of documentation: User Guide, Operation Manual, Commissioning Manual, Instruction Manual, Project Planning Manual, Application Manual, etc.
<b>Component</b>	A component is a combination of elements with a specified function, which are part of a piece of equipment, device or system. Components of the electric drive and control system are, for example, supply units, drive controllers, mains choke, mains filter, motors, cables, etc.
<b>Control System</b>	A control system comprises several interconnected control components placed on the market as a single functional unit.
<b>Device</b>	A device is a finished product with a defined function, intended for users and placed on the market as an individual piece of merchandise.
<b>Electrical Equipment</b>	Electrical equipment encompasses all devices used to generate, convert, transmit, distribute or apply electrical energy, such as electric motors, transformers, switching devices, cables, lines, power-consuming devices, circuit board assemblies, plug-in units, control cabinets, etc.
<b>Electric Drive System</b>	An electric drive system comprises all components from mains supply to motor shaft; this includes, for example, electric motor(s), motor encoder(s), supply units and drive controllers, as well as auxiliary and additional components, such as mains filter, mains choke and the corresponding lines and cables.
<b>Installation</b>	An installation consists of several devices or systems interconnected for a defined purpose and on a defined site which, however, are not intended to be placed on the market as a single functional unit.
<b>Machine</b>	A machine is the entirety of interconnected parts or units at least one of which is movable. Thus, a machine consists of the appropriate machine drive elements, as well as control and power circuits, which have been assembled for a specific application. A machine is, for example, intended for processing, treatment, movement or packaging of a material. The term "machine" also covers a combination of machines which are arranged and controlled in such a way that they function as a unified whole.
<b>Manufacturer</b>	The manufacturer is an individual or legal entity bearing responsibility for the design and manufacture of a product which is placed on the market in the individual's or legal entity's name. The manufacturer can use finished products, finished parts or finished elements, or contract out work to subcontractors. However, the manufacturer must always have overall control and possess the required authority to take responsibility for the product.
<b>Product</b>	Examples of a product: Device, component, part, system, software, firmware, among other things.
<b>Project Planning Manual</b>	A project planning manual is part of the application documentation used to support the sizing and planning of systems, machines or installations.
<b>Qualified Persons</b>	In terms of this application documentation, qualified persons are those persons who are familiar with the installation, mounting, commissioning and operation of the components of the electric drive and control system, as well as with the hazards this implies, and who possess the qualifications their work

## Safety Instructions for Electric Drives and Controls

requires. To comply with these qualifications, it is necessary, among other things,

- 1) to be trained, instructed or authorized to switch electric circuits and devices safely on and off, to ground them and to mark them
- 2) to be trained or instructed to maintain and use adequate safety equipment
- 3) to attend a course of instruction in first aid

**User** A user is a person installing, commissioning or using a product which has been placed on the market.

## 3.2 General Information

### 3.2.1 Using the Safety Instructions and Passing Them on to Others

Do not attempt to install and operate the components of the electric drive and control system without first reading all documentation provided with the product. Read and understand these safety instructions and all user documentation prior to working with these components. If you do not have the user documentation for the components, contact your responsible Bosch Rexroth sales partner. Ask for these documents to be sent immediately to the person or persons responsible for the safe operation of the components.

If the component is resold, rented and/or passed on to others in any other form, these safety instructions must be delivered with the component in the official language of the user's country.

**Improper use of these components, failure to follow the safety instructions in this document or tampering with the product, including disabling of safety devices, could result in property damage, injury, electric shock or even death.**

### 3.2.2 Requirements for Safe Use

Read the following instructions before initial commissioning of the components of the electric drive and control system in order to eliminate the risk of injury and/or property damage. You must follow these safety instructions.

- Bosch Rexroth is not liable for damages resulting from failure to observe the safety instructions.
- Read the operating, maintenance and safety instructions in your language before commissioning. If you find that you cannot completely understand the application documentation in the available language, please ask your supplier to clarify.
- Proper and correct transport, storage, mounting and installation, as well as care in operation and maintenance, are prerequisites for optimal and safe operation of the component.
- Only qualified persons may work with components of the electric drive and control system or within its proximity.
- Only use accessories and spare parts approved by Bosch Rexroth.
- Follow the safety regulations and requirements of the country in which the components of the electric drive and control system are operated.
- Only use the components of the electric drive and control system in the manner that is defined as appropriate. See chapter "Appropriate Use".
- The ambient and operating conditions given in the available application documentation must be observed.
- Applications for functional safety are only allowed if clearly and explicitly specified in the application documentation "Integrated Safety Technolo-



## Safety Instructions for Electric Drives and Controls

gy". If this is not the case, they are excluded. Functional safety is a safety concept in which measures of risk reduction for personal safety depend on electrical, electronic or programmable control systems.

- The information given in the application documentation with regard to the use of the delivered components contains only examples of applications and suggestions.

The machine and installation manufacturers must

- make sure that the delivered components are suited for their individual application and check the information given in this application documentation with regard to the use of the components,
- make sure that their individual application complies with the applicable safety regulations and standards and carry out the required measures, modifications and complements.
- Commissioning of the delivered components is only allowed once it is sure that the machine or installation in which the components are installed complies with the national regulations, safety specifications and standards of the application.
- Operation is only allowed if the national EMC regulations for the application are met.
- The instructions for installation in accordance with EMC requirements can be found in the section on EMC in the respective application documentation.

The machine or installation manufacturer is responsible for compliance with the limit values as prescribed in the national regulations.

- The technical data, connection and installation conditions of the components are specified in the respective application documentations and must be followed at all times.

*National regulations which the user must take into account*

- European countries: In accordance with European EN standards
- United States of America (USA):
  - National Electrical Code (NEC)
  - National Electrical Manufacturers Association (NEMA), as well as local engineering regulations
  - Regulations of the National Fire Protection Association (NFPA)
- Canada: Canadian Standards Association (CSA)
- Other countries:
  - International Organization for Standardization (ISO)
  - International Electrotechnical Commission (IEC)

### 3.2.3 Hazards by Improper Use

- High electrical voltage and high working current! Danger to life or serious injury by electric shock!
- High electrical voltage by incorrect connection! Danger to life or injury by electric shock!
- Dangerous movements! Danger to life, serious injury or property damage by unintended motor movements!
- Health hazard for persons with heart pacemakers, metal implants and hearing aids in proximity to electric drive systems!

## Safety Instructions for Electric Drives and Controls

- Risk of burns by hot housing surfaces!
- Risk of injury by improper handling! Injury by crushing, shearing, cutting, hitting!
- Risk of injury by improper handling of batteries!
- Risk of injury by improper handling of pressurized lines!

## 3.3 Instructions with Regard to Specific Dangers

### 3.3.1 Protection Against Contact With Electrical Parts and Housings



---

This section concerns components of the electric drive and control system with voltages of **more than 50 volts**.

---

Contact with parts conducting voltages above 50 volts can cause personal danger and electric shock. When operating components of the electric drive and control system, it is unavoidable that some parts of these components conduct dangerous voltage.

#### **High electrical voltage! Danger to life, risk of injury by electric shock or serious injury!**

- Only qualified persons are allowed to operate, maintain and/or repair the components of the electric drive and control system.
- Follow the general installation and safety regulations when working on power installations.
- Before switching on, the equipment grounding conductor must have been permanently connected to all electric components in accordance with the connection diagram.
- Even for brief measurements or tests, operation is only allowed if the equipment grounding conductor has been permanently connected to the points of the components provided for this purpose.
- Before accessing electrical parts with voltage potentials higher than 50 V, you must disconnect electric components from the mains or from the power supply unit. Secure the electric component from reconnection.
- With electric components, observe the following aspects:
  - Always wait **30 minutes** after switching off power to allow live capacitors to discharge before accessing an electric component. Measure the electrical voltage of live parts before beginning to work to make sure that the equipment is safe to touch.
- Install the covers and guards provided for this purpose before switching on.
- Never touch electrical connection points of the components while power is turned on.
- Do not remove or plug in connectors when the component has been powered.
- Under specific conditions, electric drive systems can be operated at mains protected by residual-current-operated circuit-breakers sensitive to universal current (RCDs/RCMs).

Safety Instructions for Electric Drives and Controls

- Secure built-in devices from penetrating foreign objects and water, as well as from direct contact, by providing an external housing, for example a control cabinet.

**High housing voltage and high leakage current! Danger to life, risk of injury by electric shock!**

- Before switching on and before commissioning, ground or connect the components of the electric drive and control system to the equipment grounding conductor at the grounding points.
- Connect the equipment grounding conductor of the components of the electric drive and control system permanently to the main power supply at all times. The leakage current is greater than 3.5 mA.
- Establish an equipment grounding connection with a minimum cross section according to the table below. With an outer conductor cross section smaller than 10 mm<sup>2</sup> (8 AWG), the alternative connection of two equipment grounding conductors is allowed, each having the same cross section as the outer conductors.

Cross section outer conductor	Minimum cross section equipment grounding conductor	
	Leakage current ≥ 3.5 mA	
	1 equipment grounding conductor	2 equipment grounding conductors
1,5 mm <sup>2</sup> (AWG 16)	10 mm <sup>2</sup> (AWG 8)	2 × 1,5 mm <sup>2</sup> (AWG 16)
2,5 mm <sup>2</sup> (AWG 14)		2 × 2,5 mm <sup>2</sup> (AWG 14)
4 mm <sup>2</sup> (AWG 12)		2 × 4 mm <sup>2</sup> (AWG 12)
6 mm <sup>2</sup> (AWG 10)		2 × 6 mm <sup>2</sup> (AWG 10)
10 mm <sup>2</sup> (AWG 8)		-
16 mm <sup>2</sup> (AWG 6)	16 mm <sup>2</sup> (AWG 6)	-
25 mm <sup>2</sup> (AWG 4)		-
35 mm <sup>2</sup> (AWG 2)		-
50 mm <sup>2</sup> (AWG 1/0)	25 mm <sup>2</sup> (AWG 4)	-
70 mm <sup>2</sup> (AWG 2/0)	35 mm <sup>2</sup> (AWG 2)	-
...	...	...

Fig.3-1: Minimum Cross Section of the Equipment Grounding Connection

### 3.3.2 Protective Extra-Low Voltage as Protection Against Electric Shock

Protective extra-low voltage is used to allow connecting devices with basic insulation to extra-low voltage circuits.

On components of an electric drive and control system provided by Bosch Rexroth, all connections and terminals with voltages between 5 and 50 volts are PELV ("Protective Extra-Low Voltage") systems. It is allowed to connect devices equipped with basic insulation (such as programming devices, PCs, notebooks, display units) to these connections.

## Safety Instructions for Electric Drives and Controls

### **Danger to life, risk of injury by electric shock! High electrical voltage by incorrect connection!**

If extra-low voltage circuits of devices containing voltages and circuits of more than 50 volts (e.g., the mains connection) are connected to Bosch Rexroth products, the connected extra-low voltage circuits must comply with the requirements for PELV ("Protective Extra-Low Voltage").

### 3.3.3 Protection Against Dangerous Movements

Dangerous movements can be caused by faulty control of connected motors. Some common examples are:

- Improper or wrong wiring or cable connection
- Operator errors
- Wrong input of parameters before commissioning
- Malfunction of sensors and encoders
- Defective components
- Software or firmware errors

These errors can occur immediately after equipment is switched on or even after an unspecified time of trouble-free operation.

The monitoring functions in the components of the electric drive and control system will normally be sufficient to avoid malfunction in the connected drives. Regarding personal safety, especially the danger of injury and/or property damage, this alone cannot be relied upon to ensure complete safety. Until the integrated monitoring functions become effective, it must be assumed in any case that faulty drive movements will occur. The extent of faulty drive movements depends upon the type of control and the state of operation.

### **Dangerous movements! Danger to life, risk of injury, serious injury or property damage!**

A **risk assessment** must be prepared for the installation or machine, with its specific conditions, in which the components of the electric drive and control system are installed.

As a result of the risk assessment, the user must provide for monitoring functions and higher-level measures on the installation side for personal safety. The safety regulations applicable to the installation or machine must be taken into consideration. Unintended machine movements or other malfunctions are possible if safety devices are disabled, bypassed or not activated.

#### **To avoid accidents, injury and/or property damage:**

- Keep free and clear of the machine's range of motion and moving machine parts. Prevent personnel from accidentally entering the machine's range of motion by using, for example:
  - Safety fences
  - Safety guards
  - Protective coverings
  - Light barriers
- Make sure the safety fences and protective coverings are strong enough to resist maximum possible kinetic energy.
- Mount emergency stopping switches in the immediate reach of the operator. Before commissioning, verify that the emergency stopping equip-

## Safety Instructions for Electric Drives and Controls

ment works. Do not operate the machine if the emergency stopping switch is not working.

- Prevent unintended start-up. Isolate the drive power connection by means of OFF switches/OFF buttons or use a safe starting lockout.
- Make sure that the drives are brought to safe standstill before accessing or entering the danger zone.
- Additionally secure vertical axes against falling or dropping after switching off the motor power by, for example,
  - mechanically securing the vertical axes,
  - adding an external braking/arrester/clamping mechanism or
  - ensuring sufficient counterbalancing of the vertical axes.
- The standard equipment **motor holding brake** or an external holding brake controlled by the drive controller is **not sufficient to guarantee personal safety!**
- Disconnect electrical power to the components of the electric drive and control system using the master switch and secure them from reconnection ("lock out") for:
  - Maintenance and repair work
  - Cleaning of equipment
  - Long periods of discontinued equipment use
- Prevent the operation of high-frequency, remote control and radio equipment near components of the electric drive and control system and their supply leads. If the use of these devices cannot be avoided, check the machine or installation, at initial commissioning of the electric drive and control system, for possible malfunctions when operating such high-frequency, remote control and radio equipment in its possible positions of normal use. It might possibly be necessary to perform a special electromagnetic compatibility (EMC) test.

### 3.3.4 Protection Against Magnetic and Electromagnetic Fields During Operation and Mounting

Magnetic and electromagnetic fields generated by current-carrying conductors or permanent magnets of electric motors represent a serious danger to persons with heart pacemakers, metal implants and hearing aids.

**Health hazard for persons with heart pacemakers, metal implants and hearing aids in proximity to electric components!**

- Persons with heart pacemakers and metal implants are not allowed to enter the following areas:
  - Areas in which components of the electric drive and control systems are mounted, commissioned and operated.
  - Areas in which parts of motors with permanent magnets are stored, repaired or mounted.
- If it is necessary for somebody with a heart pacemaker to enter such an area, a doctor must be consulted prior to doing so. The noise immunity of implanted heart pacemakers differs so greatly that no general rules can be given.
- Those with metal implants or metal pieces, as well as with hearing aids, must consult a doctor before they enter the areas described above.

## Safety Instructions for Electric Drives and Controls

### 3.3.5 Protection Against Contact With Hot Parts

**Hot surfaces of components of the electric drive and control system. Risk of burns!**

- Do not touch hot surfaces of, for example, braking resistors, heat sinks, supply units and drive controllers, motors, windings and laminated cores!
- According to the operating conditions, temperatures of the surfaces can be **higher than 60 °C** (140 °F) during or after operation.
- Before touching motors after having switched them off, let them cool down for a sufficient period of time. Cooling down can require **up to 140 minutes!** The time required for cooling down is approximately five times the thermal time constant specified in the technical data.
- After switching chokes, supply units and drive controllers off, wait **15 minutes** to allow them to cool down before touching them.
- Wear safety gloves or do not work at hot surfaces.
- For certain applications, and in accordance with the respective safety regulations, the manufacturer of the machine or installation must take measures to avoid injuries caused by burns in the final application. These measures can be, for example: Warnings at the machine or installation, guards (shields or barriers) or safety instructions in the application documentation.

### 3.3.6 Protection During Handling and Mounting

**Risk of injury by improper handling! Injury by crushing, shearing, cutting, hitting!**

- Observe the relevant statutory regulations of accident prevention.
- Use suitable equipment for mounting and transport.
- Avoid jamming and crushing by appropriate measures.
- Always use suitable tools. Use special tools if specified.
- Use lifting equipment and tools in the correct manner.
- Use suitable protective equipment (hard hat, safety goggles, safety shoes, safety gloves, for example).
- Do not stand under hanging loads.
- Immediately clean up any spilled liquids from the floor due to the risk of falling!

### 3.3.7 Battery Safety

Batteries consist of active chemicals in a solid housing. Therefore, improper handling can cause injury or property damage.

**Risk of injury by improper handling!**

- Do not attempt to reactivate low batteries by heating or other methods (risk of explosion and cauterization).
- Do not attempt to recharge the batteries as this may cause leakage or explosion.
- Do not throw batteries into open flames.
- Do not dismantle batteries.

## Safety Instructions for Electric Drives and Controls

- When replacing the battery/batteries, do not damage the electrical parts installed in the devices.
- Only use the battery types specified for the product.



Environmental protection and disposal! The batteries contained in the product are considered dangerous goods during land, air, and sea transport (risk of explosion) in the sense of the legal regulations. Dispose of used batteries separately from other waste. Observe the national regulations of your country.

---

### 3.3.8 Protection Against Pressurized Systems

According to the information given in the Project Planning Manuals, motors and components cooled with liquids and compressed air can be partially supplied with externally fed, pressurized media, such as compressed air, hydraulics oil, cooling liquids and cooling lubricants. Improper handling of the connected supply systems, supply lines or connections can cause injuries or property damage.

#### Risk of injury by improper handling of pressurized lines!

- Do not attempt to disconnect, open or cut pressurized lines (risk of explosion).
- Observe the respective manufacturer's operating instructions.
- Before dismantling lines, relieve pressure and empty medium.
- Use suitable protective equipment (safety goggles, safety shoes, safety gloves, for example).
- Immediately clean up any spilled liquids from the floor due to the risk of falling!



Environmental protection and disposal! The agents (e.g., fluids) used to operate the product might not be environmentally friendly. Dispose of agents harmful to the environment separately from other waste. Observe the national regulations of your country.

---

## 3.4 Explanation of Signal Words and the Safety Alert Symbol

The Safety Instructions in the available application documentation contain specific signal words (DANGER, WARNING, CAUTION or NOTICE) and, where required, a safety alert symbol (in accordance with ANSI Z535.6-2011).

The signal word is meant to draw the reader's attention to the safety instruction and identifies the hazard severity.

The safety alert symbol (a triangle with an exclamation point), which precedes the signal words DANGER, WARNING and CAUTION, is used to alert the reader to personal injury hazards.

---

**DANGER**

In case of non-compliance with this safety instruction, death or serious injury will occur.

---

## Safety Instructions for Electric Drives and Controls

---

**⚠ WARNING**

In case of non-compliance with this safety instruction, death or serious injury **could** occur.

---

---

**⚠ CAUTION**

In case of non-compliance with this safety instruction, minor or moderate injury could occur.

---

---

***NOTICE***

In case of non-compliance with this safety instruction, property damage could occur.

---



## 4 Technical Data

### 4.1 Characteristics

#### 4.1.1 General Information

The speed-torque curves and the technical data are specified for different motor overtemperatures.

The motor data and characteristic curves are determined using MKE motors under the following conditions:

- Environmental temperature max. 40 °C
- Insulated structure (aluminum flange)
- In case of motors with the optional holding brake, the data are always specified for motors **with** a holding brake.
- Motors with radial shaft sealing ring

#### 4.1.2 Operating Modes

The motors are documented according to the test criteria and measuring methods of EN 60034-1. The specified characteristic curves correspond to operating mode S1 or S3.

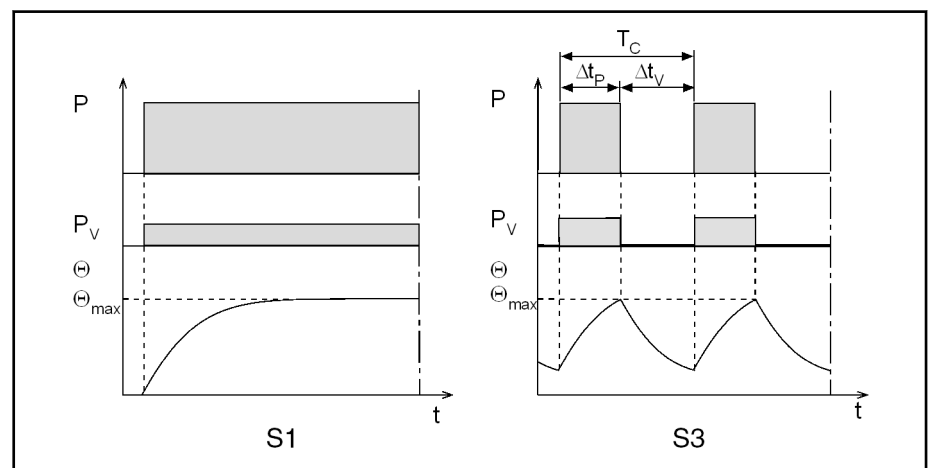

P	Load
$P_V$	Electric losses
$\Theta$	Temperature
$\Theta_{max}$	Highest temperature (motor housing)
t	Time
$T_C$	Cycle time
$\Delta t_P$	Operating time with constant load
$\Delta t_V$	Idling time

Fig.4-1: Operating modes according to EN 60034-1:1998

#### 4.1.3 Duty Cycle

Operating mode S6 is supplemented by specification of the ON time (ED) in %. The duty cycle is calculated as follows:

## Technical Data

$$ED = \frac{\Delta t_p}{T_C} \cdot 100\%$$

ED Relative duty cycle in %  
 $\Delta t_p$  Operating time with constant load

Fig.4-2: Relative duty cycle

The values specified in the documentation have been determined on the basis of the following parameters:

Cycle time: 15 min

Duty cycle DC: 25%

#### 4.1.4 Definition of Parameters

<b>Continuous torque at standstill 60K</b>	Symbol <b>M<sub>0_60</sub></b> Unit <b>Nm</b> Continuous torque that can be applied to the motor output shaft at a speed of $n \geq 0.1$ Hz.
<b>Continuous current at standstill 60K</b>	Symbol <b>I<sub>0_60(eff)</sub></b> Unit <b>A</b> Phase current (crest value) of the motor M <sub>0_60</sub> required for the continuous torque at standstill at a speed of $n \geq 0.1$ Hz.
<b>Maximum torque</b>	Symbol <b>M<sub>max</sub></b> Unit <b>Nm</b> Maximum torque that can be applied for about 400 ms at maximum current I <sub>max</sub> . The maximum torque that can be attained depends on the drive control device used. Only the specified maximum torque in the selection lists is binding.
<b>Maximum current</b>	Symbol <b>I<sub>max(eff)</sub></b> Unit <b>A</b> Maximum, briefly permissible phase current of the motor winding without adverse affect on the permanent magnet circuit of the motor.
<b>Torque constant at 20 °C</b>	Symbol <b>K<sub>M,N</sub></b> Unit <b>Nm/A</b> Relation of created torque to motor phase current at motor temperature of 20 °C. Valid up to $i = 2 \times I_{0_60}$ .
<b>Voltage constant at 20 °C</b>	Symbol <b>K<sub>EMK_1000</sub></b> Unit <b>V/min<sup>-1</sup></b> Root-mean-square value of the induced motor voltage at a motor temperature of 20 °C and 1,000 revolutions per minute.
<b>Winding resistance at 20 °C</b>	Symbol <b>R<sub>12</sub></b> Unit <b>Ohm</b> Measured winding resistance between two strands.
<b>Winding inductivity</b>	Symbol <b>L<sub>12</sub></b> Unit <b>mH</b> Measured inductivity between two strands.
<b>Discharge capacity</b>	Symbol <b>C<sub>ab</sub></b> Unit <b>nF</b> Capacity of short-circuited power connections U, V, W against the motor housing.

Technical Data

<b>Number of pole pairs</b>	Symbol <b>o</b> Unit - Quantity of pole pairs of the motor.
<b>Rotor moment of inertia</b>	Symbol <b>J<sub>rot</sub></b> Unit <b>kgm<sup>2</sup></b> Moment of inertia of the rotor without the optional holding brake. Moment of inertia of holding brake must be added if necessary.
<b>Thermal time constant</b>	Symbol <b>T<sub>th</sub></b> Unit <b>min</b> Time of the temperature increase to 63% of the final temperature of the motor housing with the motor loaded with the permissible S1 continuous torque. The thermal time constant is defined by the cooling type used.

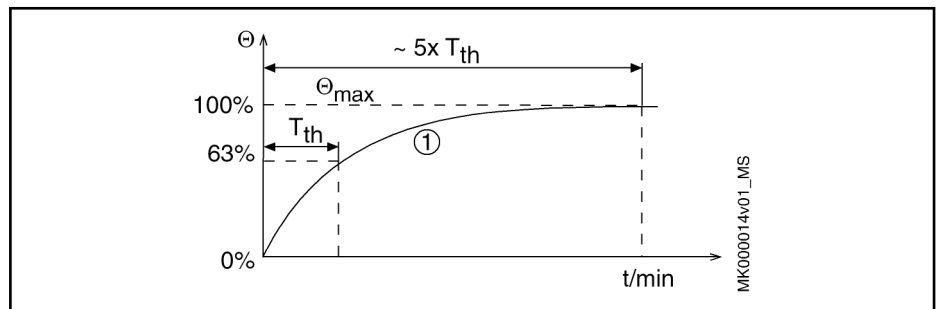

① Chronological development of the temperature at the motor housing  
 Θ<sub>max</sub> Highest temperature (motor housing)  
 T<sub>th</sub> Thermal time constant  
*Fig.4-3: Thermal time constant*

<b>Maximum velocity</b>	Symbol <b>n<sub>max</sub></b> Unit <b>min<sup>-1</sup></b> Maximum permissible velocity of the motor.
<b>Sound pressure level</b>	Symbol <b>L<sub>p</sub></b> Unit <b>dB(A)</b> Determined values for 1 m distance from motor to measuring point.
<b>Mass</b>	Symbol <b>m</b> Unit <b>kg</b> Motor mass, value in brackets for motors with holding brakes.
<b>Ambient temperature in operation</b>	Symbol <b>T<sub>um</sub></b> Unit <b>°C</b> 0 ... 40 °C
<b>Degree of protection</b>	Symbol - Unit - IP protection mode according to EN 60529
<b>Insulation class</b>	Symbol - Unit - Insulation class according to DIN EN 60034-1
<b>Holding torque</b>	Symbol <b>M<sub>4</sub></b> Unit <b>Nm</b> Transferable holding torque of holding brake.

## Technical Data

**Rated voltage (+/-10 %)**Symbol  $U_N$ Unit **V**Input voltage of the holding brake [chapter 9.12.1 "Holding Brake Electrically-Released"](#) on page 90.**Rated current**Symbol  $I_N$ Unit **A**

Current consumption of the holding brake.

**Connection time**Symbol  $t_1$ Unit **ms**

Time until the holding brake applies.

**Disconnection time**Symbol  $t_2$ Unit **ms**

Time until the holding brake releases.

**Moment of inertia of the brake**Symbol  $J_{Br}$ Unit **kgm<sup>2</sup>**

The moment of inertia of holding brake must be added to the moment of inertia of the motor to determine the total moment of inertia.

## 4.2 UL File Number

Motor	UL File
MKE□□□□-□□□-□□□-□E□□	E163211
MKE□□□□-□□□-□□□-□U□□	E203009

Fig.4-4: UL File number

## Technical Data

## 4.3 Technical Data Encoder for MKE Motors

## Data Sheet

Designation	Symbol	Unit	MKE037□-□□□□-A MKE047□-□□□□-A MKE098□-□□□□-A MKE118□-□□□□-A	MKE098□-□□□□-B MKE118□-□□□□-B	MKE037□-□□□□-C MKE047□-□□□□-C MKE098□-□□□□-C MKE118□-□□□□-C	MKE098□-□□□□-D MKE118□-□□□□-D
Interface			Hiperface	EnDat 2.1	Hiperface	EnDat 2.1
Encoder design			Singleturn absolute	Singleturn absolute	Multiturn absolute	Multiturn absolute
Distinguishable revolutions			1	1	4,096	4,096
Resolution of encoder			12 bit	13 bit	12 bit	13 bit
Number of lines			128	2,048	128	2,048
System accuracy		Angular seconds	±120	±20	±120	±20
Incremental signals			1V <sub>ss</sub>			
Maximum encoder speed		min <sup>-1</sup>	12,000	15,000	9,000	12,000
Max. current consumption	I <sub>Encoder</sub>	mA	60	150	60	250
Supply voltage	V <sub>CC</sub> <sub>Encoder</sub>	V	7 ... 12	3,6 ... 14	7 ... 12	3,6 ... 14

Fig. 4-5: Technical data MKE encoder

## Calculation Example

The actual **Position resolution** can be done for every encoder type according to the following calculation.

Positionsauflösung für MKE037B-□□□□-C□□□□

From table:

Distinguishable revolutions	<b>4,096</b>
Resolution of encoder	<b>12 bit</b>
Number of lines	<b>128</b>

Position resolution = number of lines x resolution of encoder x distinguishable revolutions

$$\text{Position resolution} = 128 \times 2^{12} \times 4,096 = \mathbf{2.147.483.648} \text{ information}$$

## Optical encoder: Singleturn option A, B

These encoders permit absolute, indirect position recording within **one** mechanical rotation. The encoders replace separate incremental encoders on the motor.



After a power failure or after the first POWER ON, the axis must always at first be moved to its home position.

**Exception:** Applications in which the maximum working path is within one mechanical rotation of the motor.

## Optical encoder: Multiturn absolute option C, D

These encoders permit absolute, indirect position recording within **4,096** mechanical rotations. The encoders replace a separate absolute value encoder on the motor. With this encoder version, the absolute position of the axis is preserved even after a switch-off.

## 4.4 Technical Data Holding Brakes

Technical data holding brake (optional)

Designation	Symbol	Unit	MKE037B-□□□□-□□1	MKE047B-□□□□-□□1	MKE098B-□□□□-□□1	MKE118B-□□□□-□□1	MKE118D-□□□□-□□3	
Holding torque	$M_4$	Nm	1.0	2.2	11.0	32.0	70.0	
Rated voltage	$U_N$	V	24					
Rated current	$I_N$	A	0.40	0.34	0.71	0.93	1.29	
Connection time	$t_1$	ms	3	14	13	15	53	
Disconnection time	$t_2$	ms	4	28	30	115	97	
Holding brake moment of inertia	$J_{rot}$	kg*m <sup>2</sup>	0.000007	0.000010	0.000360	0.001242	0.00318	
Latest amendment: 2007-10-18								

Fig. 4-6: Technical data holding brake (optional)

## Technical Data

## 4.5 MKE037B Technical Data

Designation	Symbol	Unit	MKE037B-144-□□0-□□□□	MKE037B-144-□□1-□□□□
Continuous torque at standstill 60 K	$M_{0\_60}$	Nm	0.9	0.8
Continuous current at standstill 60 K	$I_{0\_60(rms)}$	A	3.3	3.0
Maximum torque	$M_{max}$	Nm	4.0	
Maximum current	$I_{max(rms)}$	A	15.0	
Torque constant at 20 °C	$K_m$	Nm/A	0.30	
Voltage constant at 20 °C <sup>1)</sup>	$K_{EMK\_1000}$	V/min <sup>-1</sup>	18.2	
Winding resistance at 20 °C	$R_{12}$	Ohm	3.70	
Winding inductivity	$L_{12}$	mH	2.700	
Discharge capacity of the component	$C_{dis}$	nF	1.0	
Number of pole pairs	$p$		3	
Moment of inertia of the rotor	$J_{rot}$	kgm <sup>2</sup>	0.00003	
Weight <sup>2)</sup>	$m_{mot}$	kg	2.5	
Thermal time constant	$T_{th}$	min	15.0	
Maximum velocity	$n_{max}$	min <sup>-1</sup>	9,000	
Sound pressure level	$L_p$	dB[A]	64.3 (±3)	
Surrounding air temperature during operation	$T_{amb}$	°C	0 ... 40	
Type of protection according to IEC 60529	---		IP 65	
Insulation class according to DIN EN 60034-1	---		155	

Latest amendment: 2010-03-16

- 1) Manufacturing tolerance ±5 %  
 2) Mass motor without holding brake  
 Fig.4-7: Technical data MKE



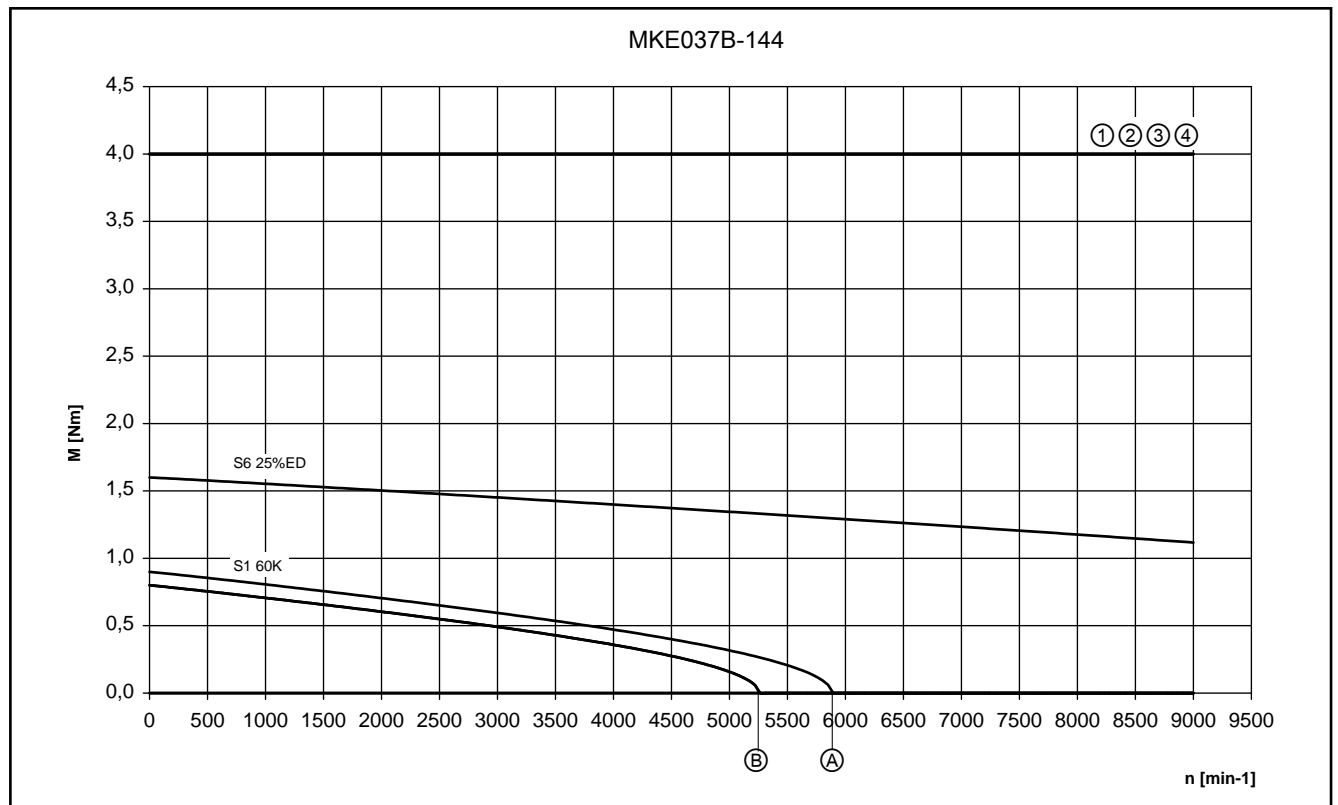

- $M_{max}$  ① IndraDrive, controlled feed 3 x AC 400V
  - $M_{max}$  ② IndraDrive, uncontrolled feed 3 x AC 480V
  - $M_{max}$  ③ IndraDrive, uncontrolled feed 3 x AC 440V
  - $M_{max}$  ④ IndraDrive, uncontrolled feed 3 x AC 400V
  - Ⓐ Characteristic curve for S1<sub>60K</sub> with holding brake
  - Ⓑ Characteristic curve for S1<sub>60K</sub> without holding brake
- Fig. 4-8: Motor characteristic curve MKE037B-144

## Technical Data

## 4.6 MKE047B Technical Data

## Technical Data

Designation	Symbol	Unit	MKE047B-144-□□□-□□□□
Continuous torque at standstill 60 K	$M_{0,60}$	Nm	2.7
Continuous current at standstill 60 K	$I_{0,60(rms)}$	A	5.0
Maximum torque	$M_{max}$	Nm	11.3
Maximum current	$I_{max(rms)}$	A	22.6
Torque constant at 20 °C	$K_m$	Nm/A	0.59
Voltage constant at 20 °C <sup>1)</sup>	$K_{EMK\_1000}$	V/min <sup>-1</sup>	36.3
Winding resistance at 20 °C	$R_{12}$	Ohm	5.00
Winding inductivity	$L_{12}$	mH	1.800
Discharge capacity of the component	$C_{dis}$	nF	1.6
Number of pole pairs	$p$		3
Moment of inertia of the rotor	$J_{rot}$	kgm <sup>2</sup>	0.00017
Weight <sup>2)</sup>	$m_{mot}$	kg	5.5
Thermal time constant	$T_{th}$	min	30.0
Maximum velocity	$n_{max}$	min <sup>-1</sup>	7,000
Sound pressure level	$L_p$	dB[A]	63.0 (±3)
Surrounding air temperature during operation	$T_{amb}$	°C	0 ... 40
Type of protection according to IEC 60529	---		IP 65
Insulation class according to DIN EN 60034-1	---		155
Latest amendment: 2010-03-18			

- 1) Manufacturing tolerance ±5 %  
 2) Mass motor without holding brake  
 Fig.4-9: Technical data MKE

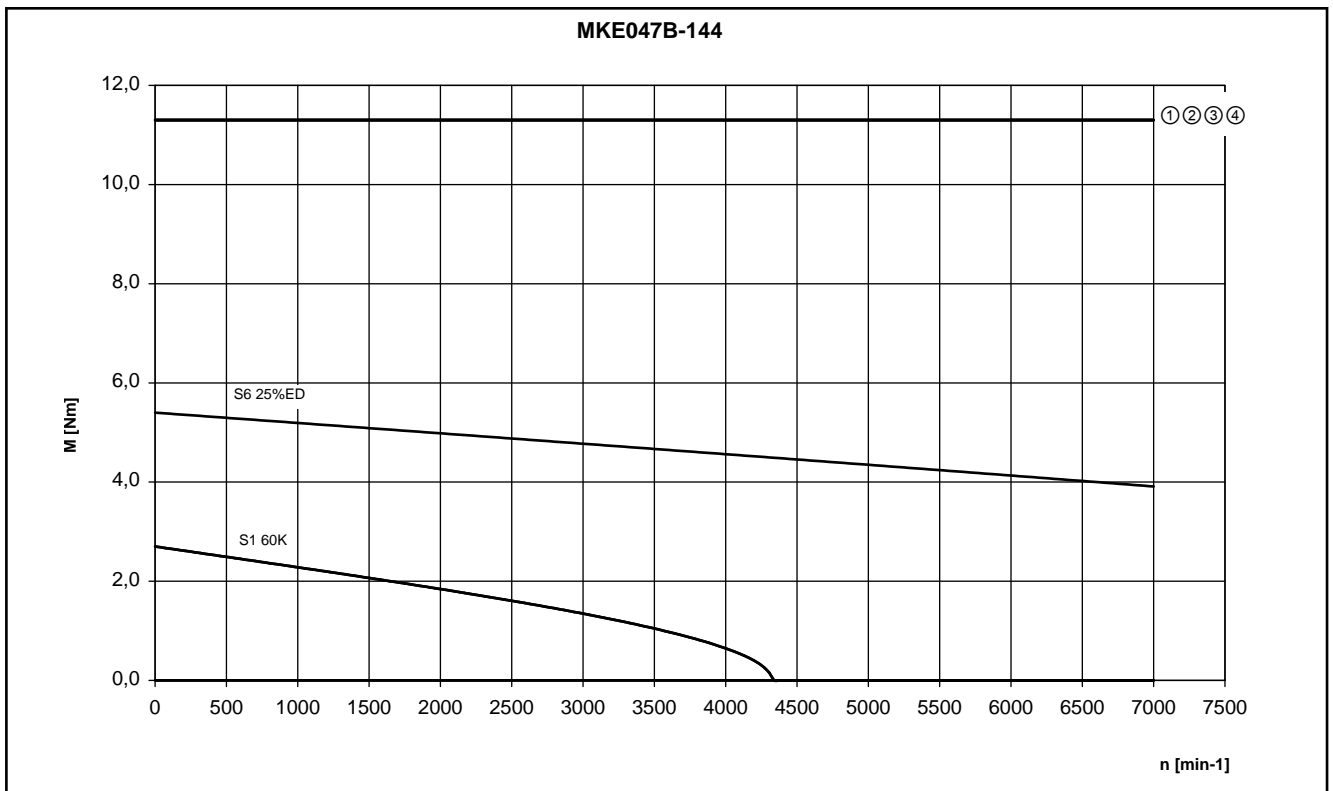

- $M_{max①}$  IndraDrive, controlled feed 3 x AC 400V
  - $M_{max②}$  IndraDrive, uncontrolled feed 3 x AC 480V
  - $M_{max③}$  IndraDrive, uncontrolled feed 3 x AC 440V
  - $M_{max④}$  IndraDrive, uncontrolled feed 3 x AC 400V
- Fig.4-10: Motor characteristic curve MKE047B-144*

## Technical Data

## 4.7 MKE098B Technical Data

## Technical Data

Designation	Symbol	Unit	MKE098B-047-□□□-□□□□	MKE098B-058-□□□-□□□□
Continuous torque at standstill 60 K	$M_{0\_60}$	Nm	12.0	
Continuous current at standstill 60 K	$I_{0\_60(rms)}$	A	9.8	12.4
Maximum torque	$M_{max}$	Nm	43.5	
Maximum current	$I_{max(rms)}$	A	44.3	55.9
Torque constant at 20 °C	$K_m$	Nm/A	1.41	1.09
Voltage constant at 20 °C <sup>1)</sup>	$K_{EMK\_1000}$	V/min <sup>-1</sup>	91.0	70.0
Winding resistance at 20 °C	$R_{12}$	Ohm	8.400	5.80
Winding inductivity	$L_{12}$	mH	1.20	0.740
Discharge capacity of the component	$C_{dis}$	nF	6.7	
Number of pole pairs	$p$		4	
Moment of inertia of the rotor	$J_{rot}$	kgm <sup>2</sup>	0.00430	
Weight <sup>2)</sup>	$m_{mot}$	kg	18.0	
Thermal time constant	$T_{th}$	min	60.0	
Maximum velocity	$n_{max}$	min <sup>-1</sup>	4,500	5,000
Sound pressure level	$L_p$	dB[A]	61.8 (±3)	
Surrounding air temperature during operation	$T_{amb}$	°C	0 ... 40	
Type of protection according to IEC 60529	---		IP 65	
Insulation class according to DIN EN 60034-1	---		155	
Latest amendment: 2012-07-13				

1) Manufacturing tolerance ±5 %

2) Mass motor without holding brake

Fig.4-11: Technical data MKE

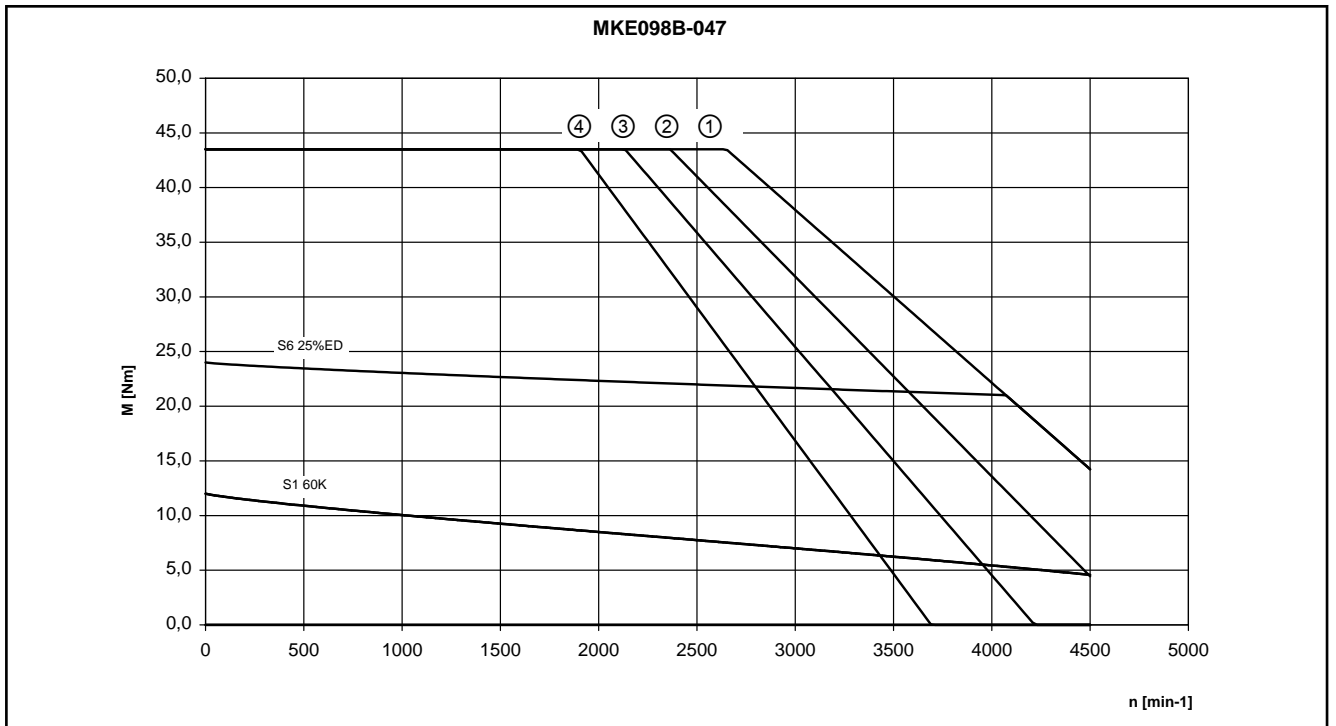

- $M_{max1}$  ① IndraDrive, controlled feed 3 x AC 400V
- $M_{max2}$  ② IndraDrive, uncontrolled feed 3 x AC 480V
- $M_{max3}$  ③ IndraDrive, uncontrolled feed 3 x AC 440V
- $M_{max4}$  ④ IndraDrive, uncontrolled feed 3 x AC 400V

Fig.4-12: Motor characteristic curve MKE098B-047

## Technical Data

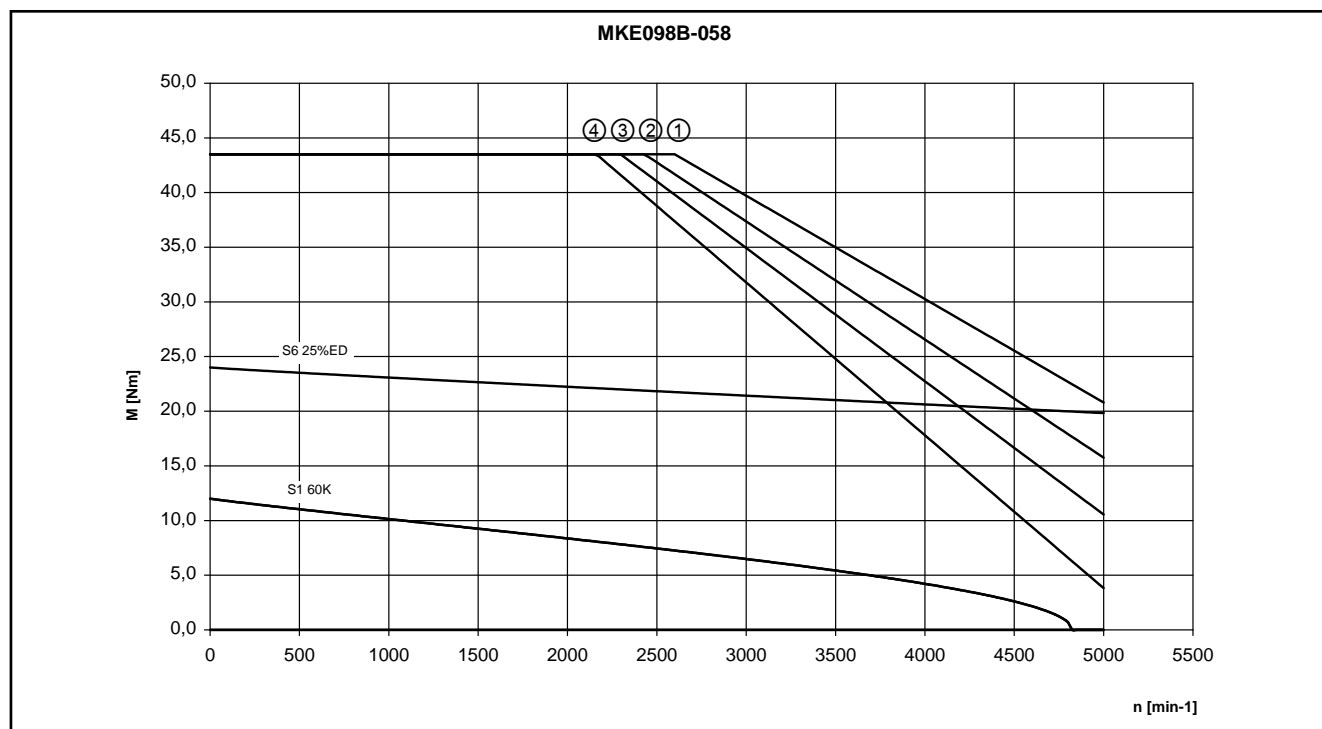

- $M_{max1}$  ① IndraDrive, controlled feed 3 x AC 400V  
 $M_{max2}$  ② IndraDrive, uncontrolled feed 3 x AC 480V  
 $M_{max3}$  ③ IndraDrive, uncontrolled feed 3 x AC 440V  
 $M_{max4}$  ④ IndraDrive, uncontrolled feed 3 x AC 400V  
 Fig. 4-13: Motor characteristic curves MKE098B-058



## Technical Data

## 4.8 MKE118B Technical Data

## Technical Data

Designation	Symbol	Unit	MKE118B-024-□□□-□□□	MKE118B-058-□□□-□□□
Continuous torque at standstill 60 K	$M_{0\_60}$	Nm	28.0	
Continuous current at standstill 60 K	$I_{0\_60(rms)}$	A	15.3	28.4
Maximum torque	$M_{max}$	Nm	102.0	
Maximum current	$I_{max(rms)}$	A	69.1	127.6
Torque constant at 20 °C	$K_m$	Nm/A	2.12	1.15
Voltage constant at 20 °C <sup>1)</sup>	$K_{EMK\_1000}$	V/min <sup>-1</sup>	130.0	70.0
Winding resistance at 20 °C	$R_{12}$	Ohm	7.60	2.20
Winding inductivity	$L_{12}$	mH	0.580	0.170
Discharge capacity of the component	$C_{dis}$	nF	10.3	
Number of pole pairs	$p$		4	
Moment of inertia of the rotor	$J_{rot}$	kgm <sup>2</sup>	0.01940	
Weight <sup>2)</sup>	$m_{mot}$	kg	45.0	
Thermal time constant	$T_{th}$	min	90.0	
Maximum velocity	$n_{max}$	min <sup>-1</sup>	4,000	4,500
Sound pressure level	$L_p$	dB[A]	61.1 (±3)	
Surrounding air temperature during operation	$T_{amb}$	°C	0 ... 40	
Type of protection according to IEC 60529	---		IP 65	
Insulation class according to DIN EN 60034-1	---		155	

Latest amendment: 2010-03-18

- 1) Manufacturing tolerance ±5 %  
 2) Mass motor without holding brake  
 Fig.4-14: Technical data MKE



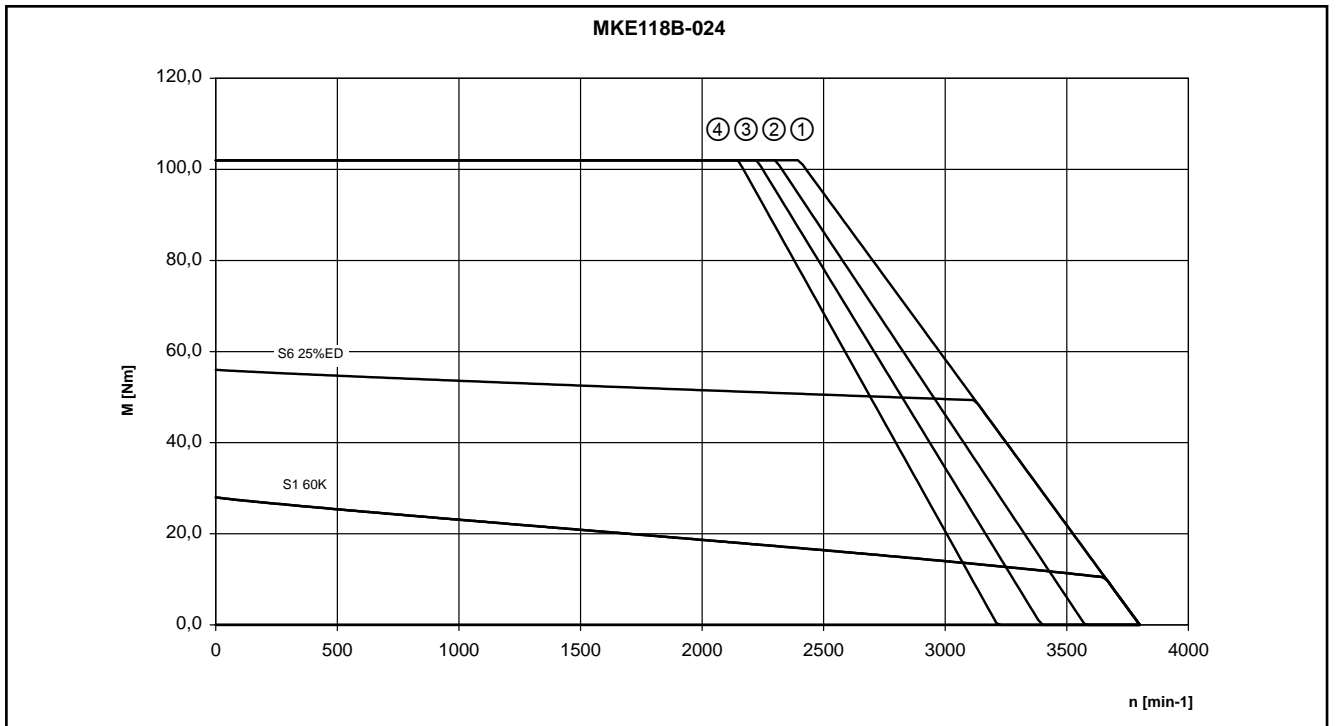

- $M_{max}$ ① IndraDrive, controlled feed 3 x AC 400V
- $M_{max}$ ② IndraDrive, uncontrolled feed 3 x AC 480V
- $M_{max}$ ③ IndraDrive, uncontrolled feed 3 x AC 440V
- $M_{max}$ ④ IndraDrive, uncontrolled feed 3 x AC 400V

Fig.4-15: Motor characteristic curve MKE118B-024

## Technical Data

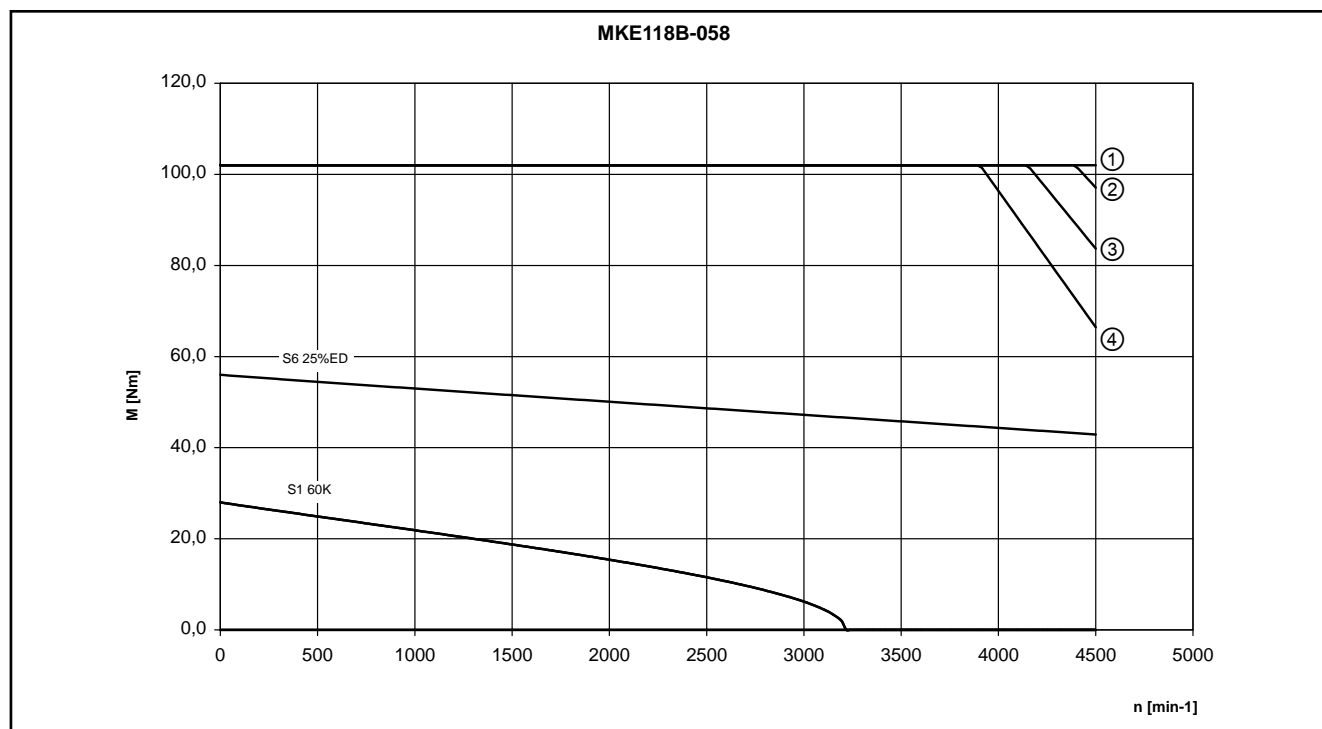

- $M_{max}$ ① IndraDrive, controlled feed 3 x AC 400V  
 $M_{max}$ ② IndraDrive, uncontrolled feed 3 x AC 480V  
 $M_{max}$ ③ IndraDrive, uncontrolled feed 3 x AC 440V  
 $M_{max}$ ④ IndraDrive, uncontrolled feed 3 x AC 400V  
 Fig. 4-16: Motor characteristic curve MKE118B-058



## Technical Data

## 4.9 MKE118D Technical Data

## Technical Data

Designation	Symbol	Unit	MKE118D-012 -□□□-□□□	MKE118B-027 -□□□-□□□	MKE118D-035 -□□□-□□□
Continuous torque at standstill 60 K	$M_{0,60}$	Nm	48.0		
Continuous current at standstill 60 K	$I_{0,60(rms)}$	A	13.0	22.1	29.8
Maximum torque	$M_{max}$	Nm	187.0		
Maximum current	$I_{max(rms)}$	A	58.5	99.6	134.3
Torque constant at 20 °C	$K_m$	Nm/A	4.29	2.52	1.87
Voltage constant at 20 °C <sup>1)</sup>	$K_{EMK\_1000}$	V/min <sup>-1</sup>	263.5	154.5	114.5
Winding resistance at 20 °C	$R_{12}$	Ohm	0.98	0.350	0.210
Winding inductivity	$L_{12}$	mH	15.000	5.70	3.20
Discharge capacity of the component	$C_{dis}$	nF	20.2		
Number of pole pairs	$o$		4		
Moment of inertia of the rotor	$J_{rot}$	kgm <sup>2</sup>	0.03620		
Weight <sup>2)</sup>	$m_{mot}$	kg	65.0		
Thermal time constant	$T_{th}$	min	90.0		
Maximum velocity	$n_{max}$	min <sup>-1</sup>	2,000	3,000	
Sound pressure level	$L_P$	dB[A]	61.1 (±3)		
Surrounding air temperature during operation	$T_{amb}$	°C	0 ... 40		
Type of protection according to IEC 60529	---		IP 65		
Insulation class according to DIN EN 60034-1	---		155		

Latest amendment: 2011-08-03

- 1) Manufacturing tolerance ±5 %  
 2) Mass motor without holding brake  
 Fig.4-17: Technical data MKE

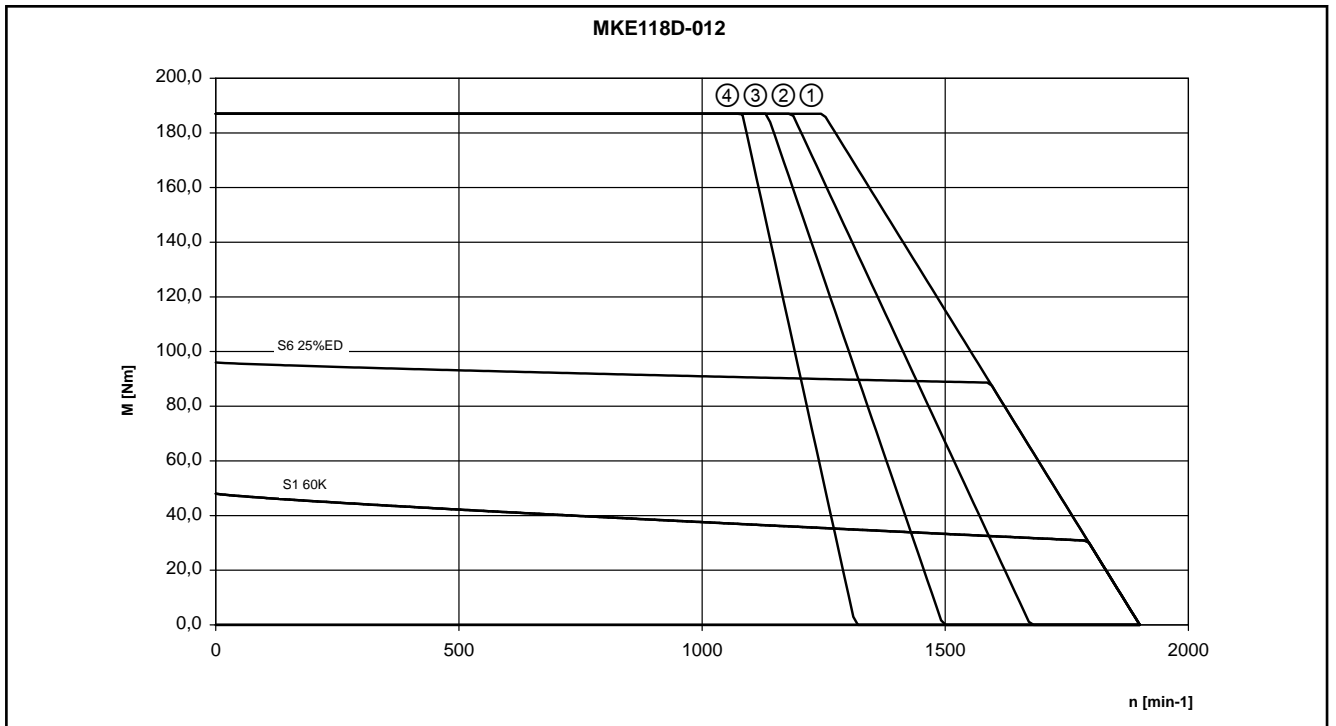

- M<sub>max</sub>① IndraDrive, controlled feed 3 x AC 400V
- M<sub>max</sub>② IndraDrive, uncontrolled feed 3 x AC 480V
- M<sub>max</sub>③ IndraDrive, uncontrolled feed 3 x AC 440V
- M<sub>max</sub>④ IndraDrive, uncontrolled feed 3 x AC 400V

Fig.4-18: Motor characteristic curve MKE118D-012

## Technical Data

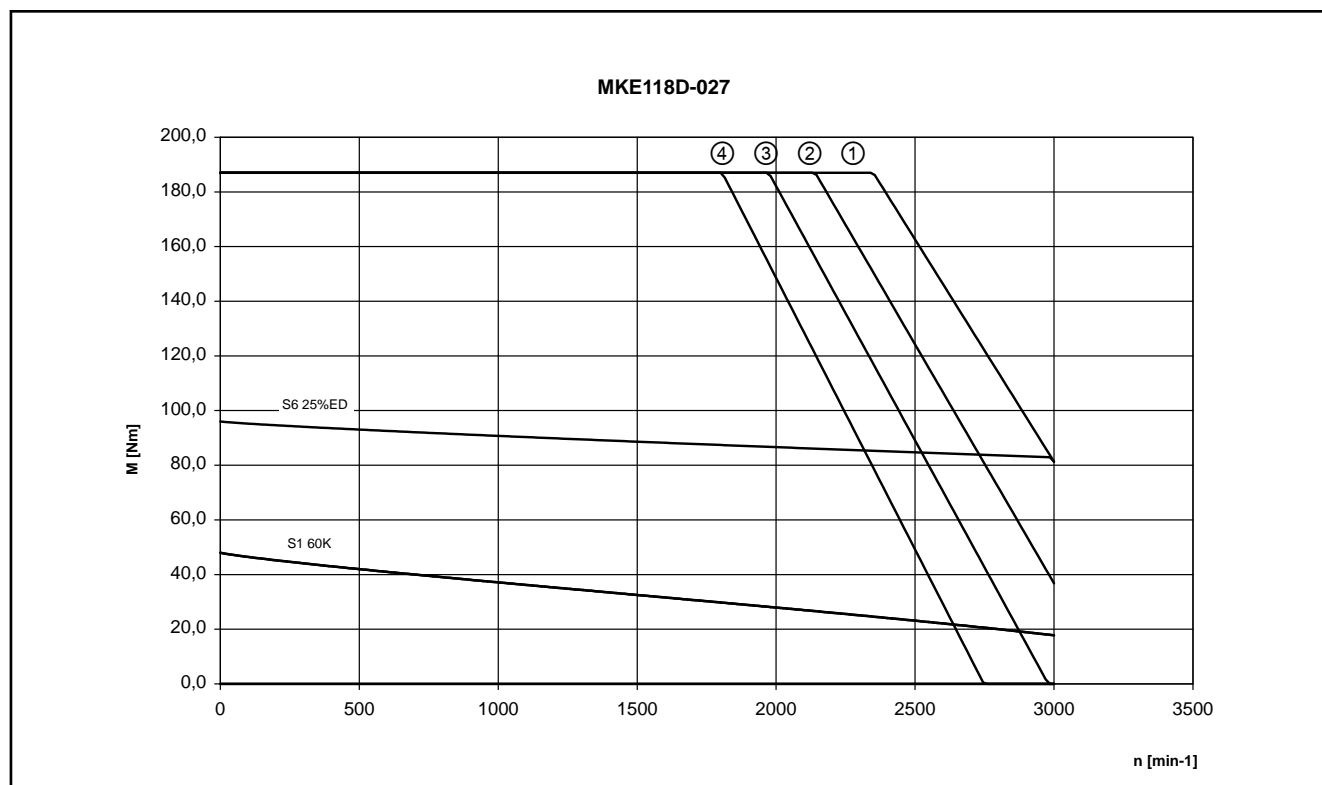
 $M_{max①}$ 

IndraDrive, controlled feed 3 x AC 400V

 $M_{max②}$ 

IndraDrive, uncontrolled feed 3 x AC 480V

 $M_{max③}$ 

IndraDrive, uncontrolled feed 3 x AC 440V

 $M_{max④}$ 

IndraDrive, uncontrolled feed 3 x AC 400V

Fig.4-19:

Motor characteristic curve MKE118D-027

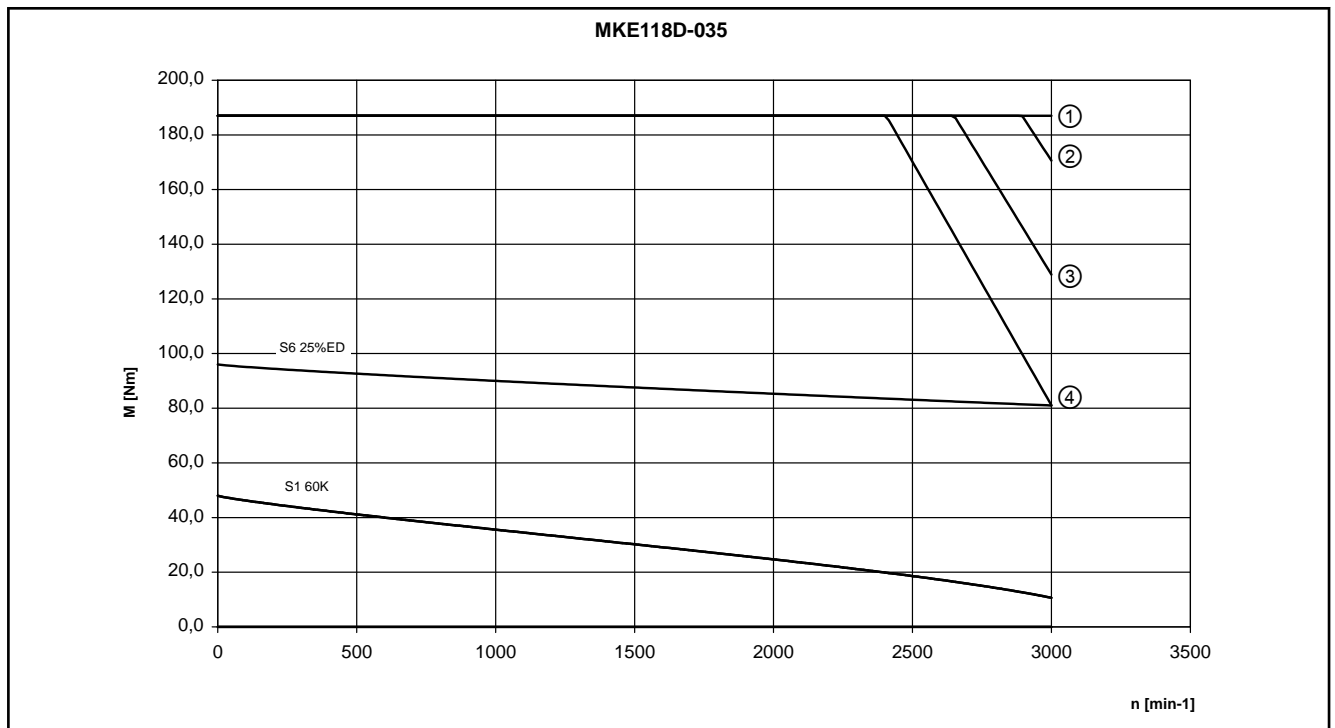

- $M_{max}$ ① IndraDrive, controlled feed 3 x AC 400V
- $M_{max}$ ② IndraDrive, uncontrolled feed 3 x AC 480V
- $M_{max}$ ③ IndraDrive, uncontrolled feed 3 x AC 440V
- $M_{max}$ ④ IndraDrive, uncontrolled feed 3 x AC 400V

Fig.4-20: Motor characteristic curve MKE118D-035





# 5 Specifications

## 5.1 MKE037 Specifications

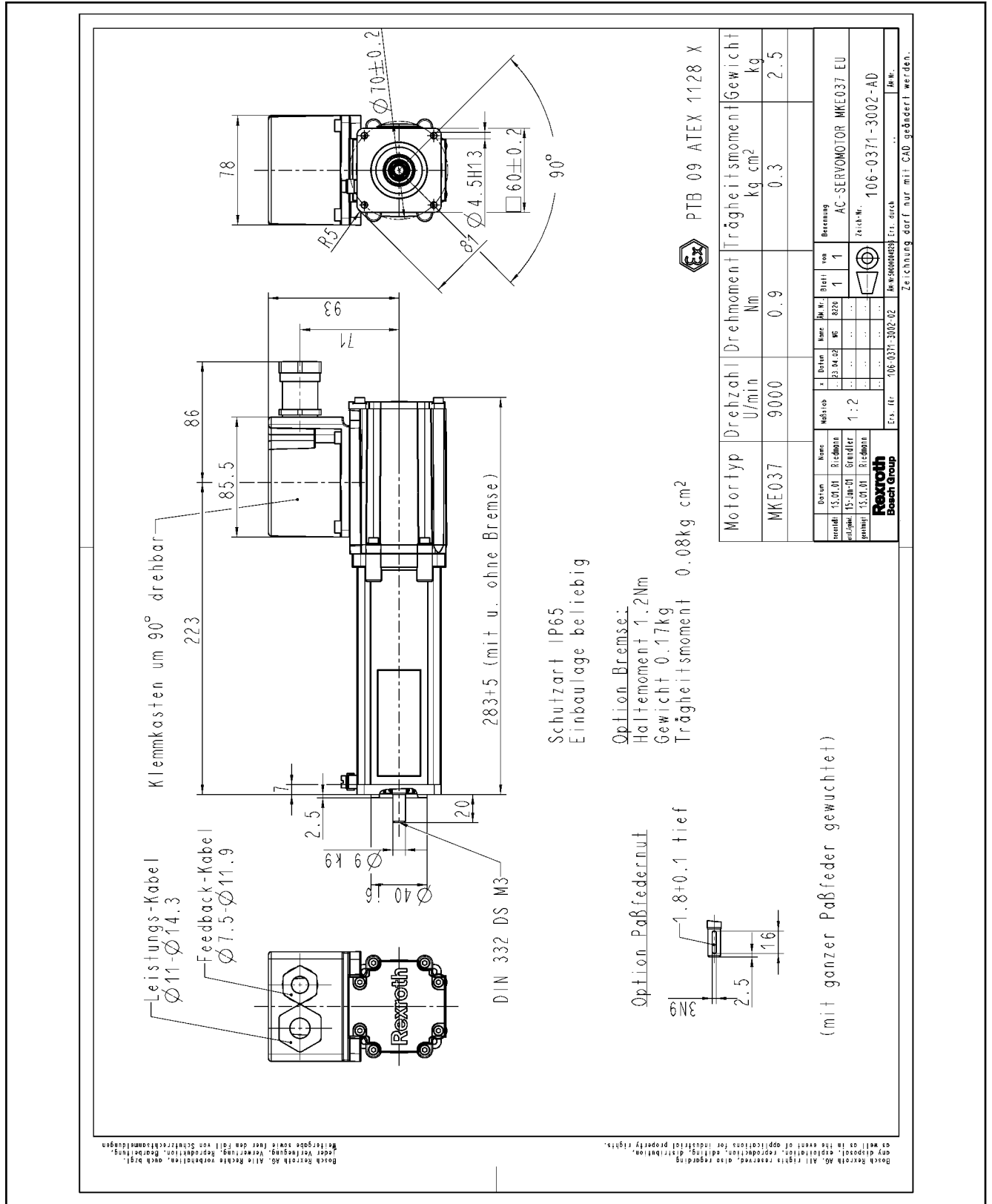

Fig.5-1: MKE037 ATEX specifications

Specifications

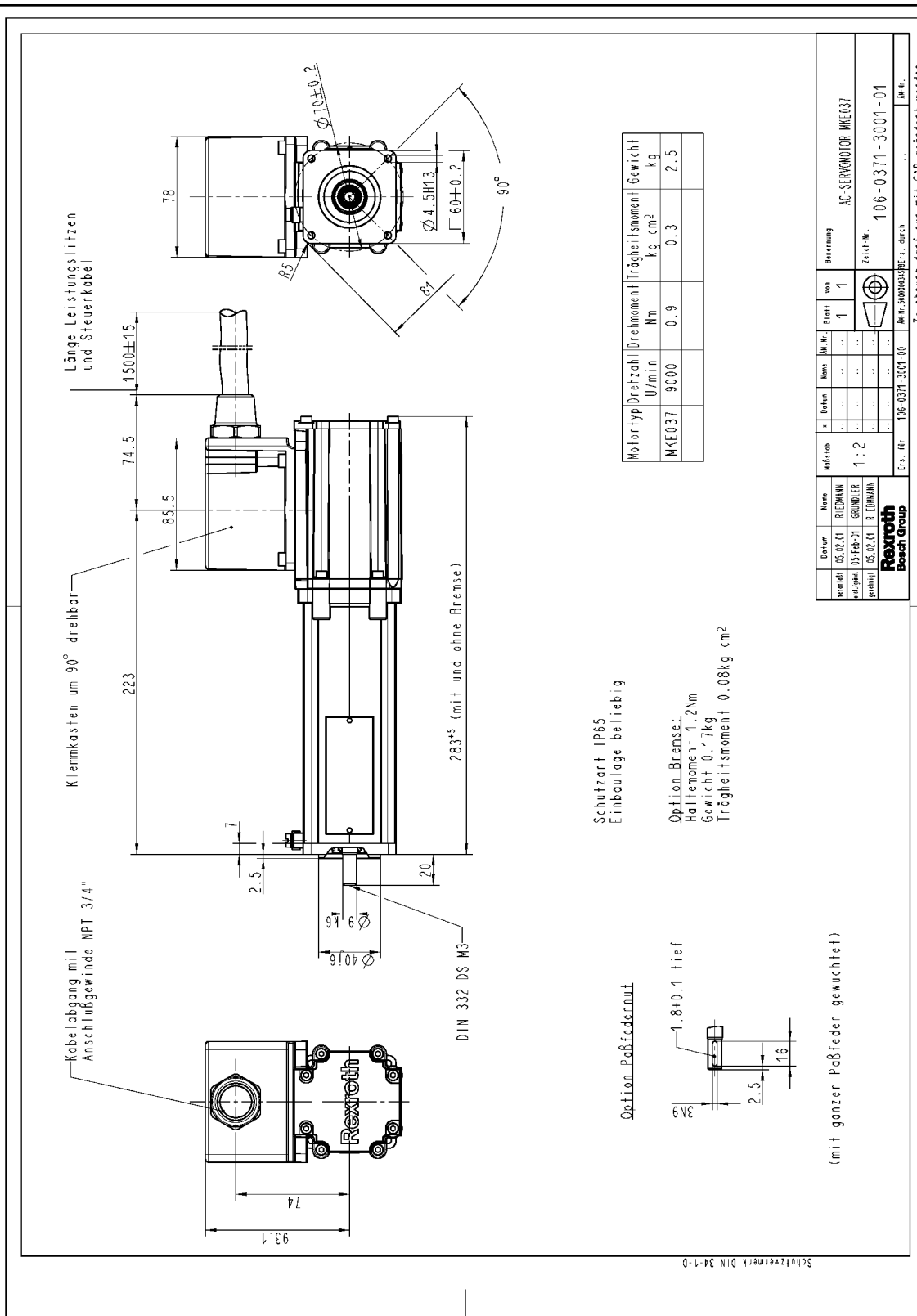

Fig.5-2: Dimensions MKE037 UL/CSA

Specifications

Shaft end

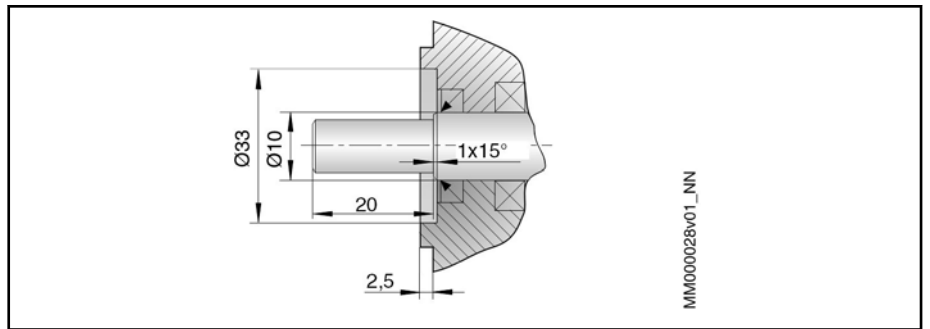

Fig.5-3: Shaft end MKE037

- Shaft end cylindrical according to DIN 748, Part 3, ed. 07.75. IEC 60072 (1971).
  - DS M3 centering hole according to DIN 332, Part 2, ed. 05.83, max. tightening torque for screw 0.7 Nm.
  - Vibration severity grade N according to DIN VDE 0530, Part 14, ed. 02.93.
- Motor Design**
- Motor design B5 according to EN 60034-7 / 1993 for all installation positions.
- Flange**
- Flange according to DIN 42948, ed. 11.65.
  - Positional accuracy with regard to true running, axial running and coaxiality to the shaft according to DIN 42955 Tolerance Class N, ed. 12.81
- Output Shaft**
- Plain shaft (preferred type)
- or
- Shaft with keyway according to DIN 6885, Sheet 1, ed. 08.68.



Caution! Balanced with key!

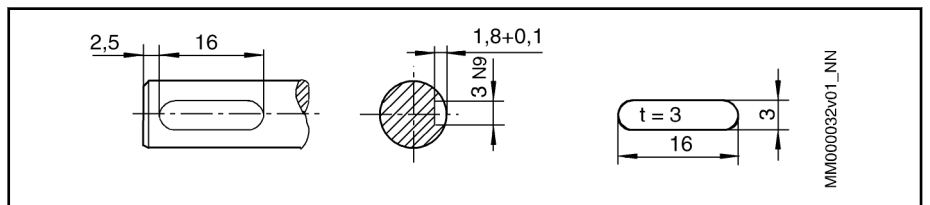

Fig.5-4: Output shaft with keyway MKE037



Pertinent key: DIN 6885-A 3 x 3 x 16; not included in the scope of delivery of the motor.

Options

For options refer to the chapter entitled "Type Code – Ordering Name".

Specifications

5.2 MKE047 Specifications

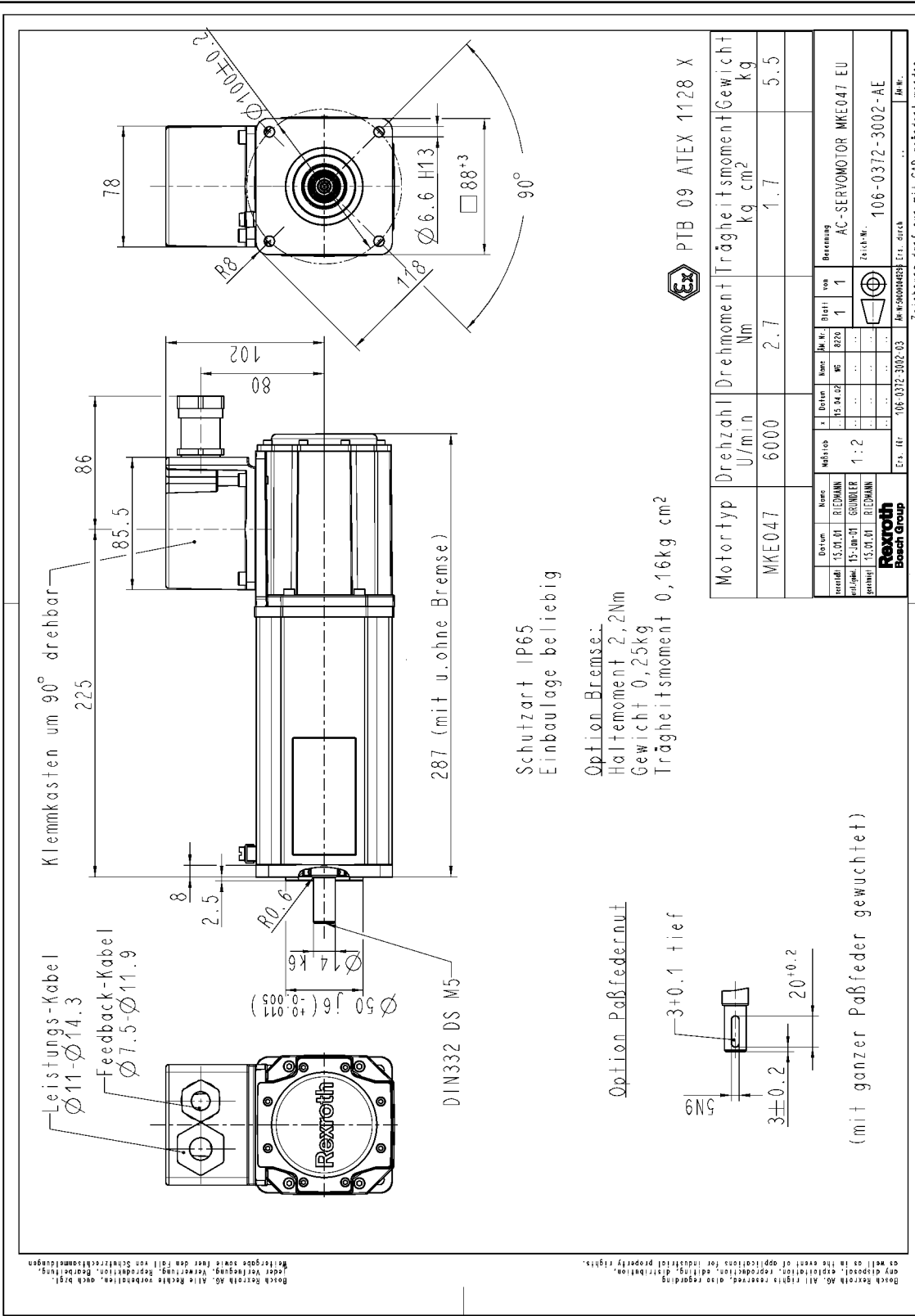

Fig.5-5: MKE047 ATEX specifications

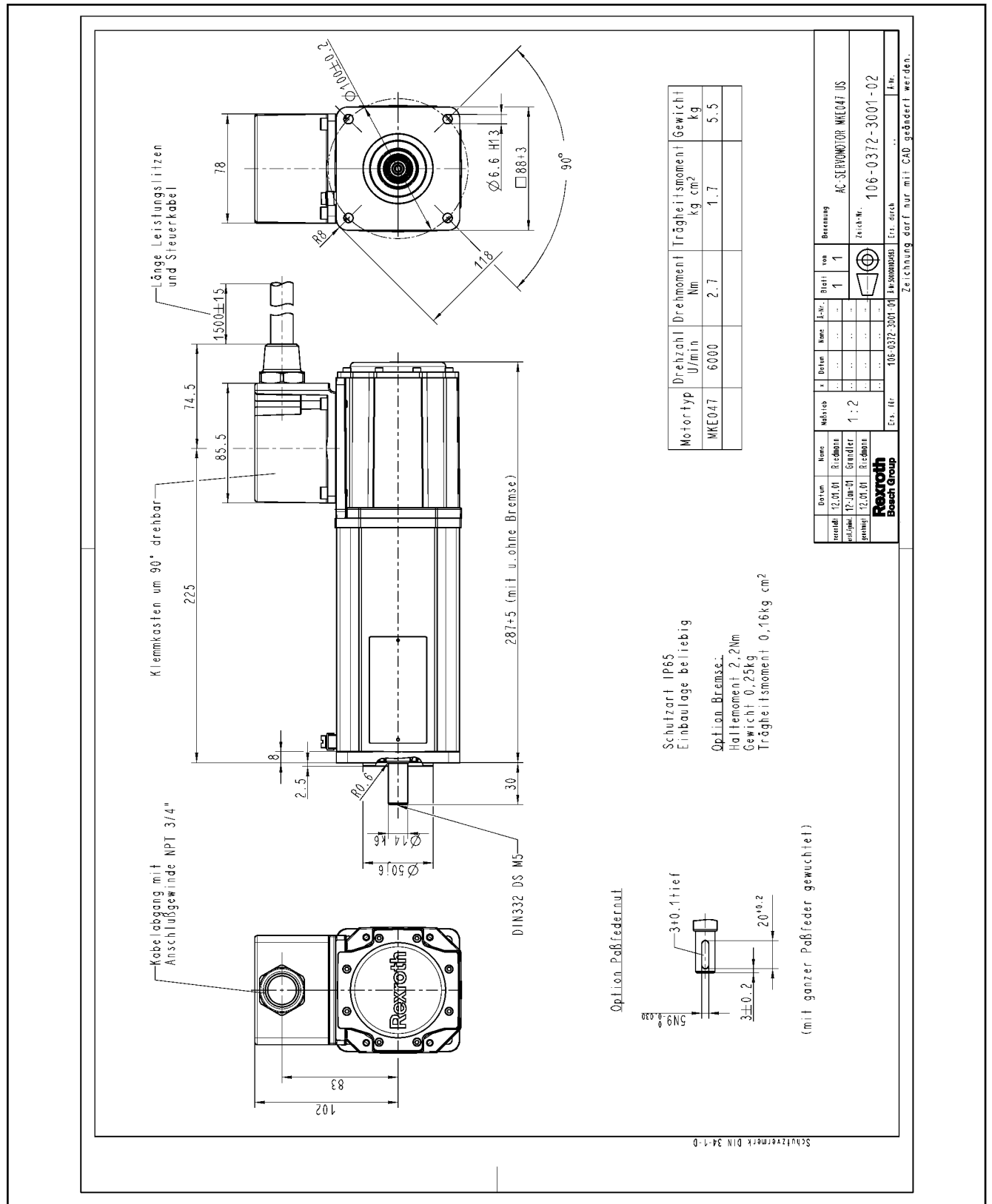

Fig.5-6: Dimensions MKE047 UL/CSA

## Specifications

## Shaft end

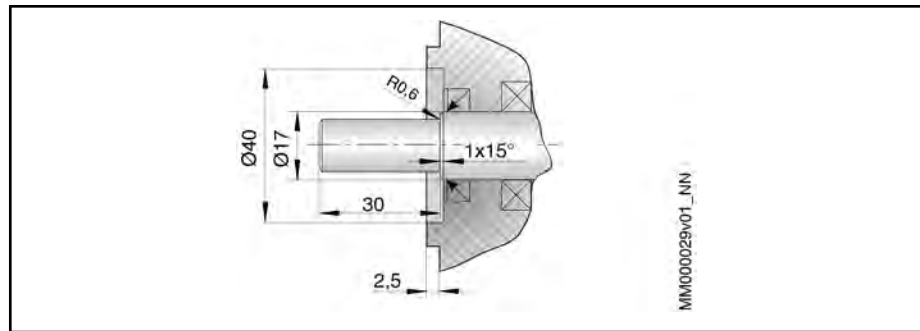

Fig.5-7: Shaft end MKE047

- Shaft end cylindrical according to DIN 748, Part 3, ed. 07.75. IEC 60072 (1971).
  - DS M5 centering hole according to DIN 332, Part 2, ed. 05.83, max. tightening torque for screw 3.0 Nm.
  - Vibration severity grade N according to DIN VDE 0530, Part 14, ed. 02.93.
- Motor Design**
- Motor design B5 according to EN 60034-7 / 1993 for all installation positions.
- Flange**
- Flange according to DIN 42948, ed. 11.65.
  - Positional accuracy with regard to true running, axial running and coaxiality to the shaft according to DIN 42955 Tolerance Class N, ed. 12.81
- Output Shaft**
- Plain shaft (preferred type)
- or
- Shaft with keyway according to DIN 6885, Sheet 1, ed. 08.68.



Caution! Balanced with key!

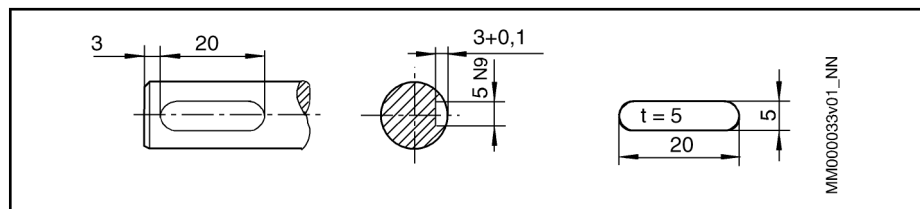

Fig.5-8: Output shaft with keyway MKE047



Pertinent key: DIN 6885-A 5 x 5 x 20; not included in the scope of delivery of the motor.

**Options** For options refer to the chapter entitled "Type Code – Ordering Name".

### 5.3 MKE098 Specifications

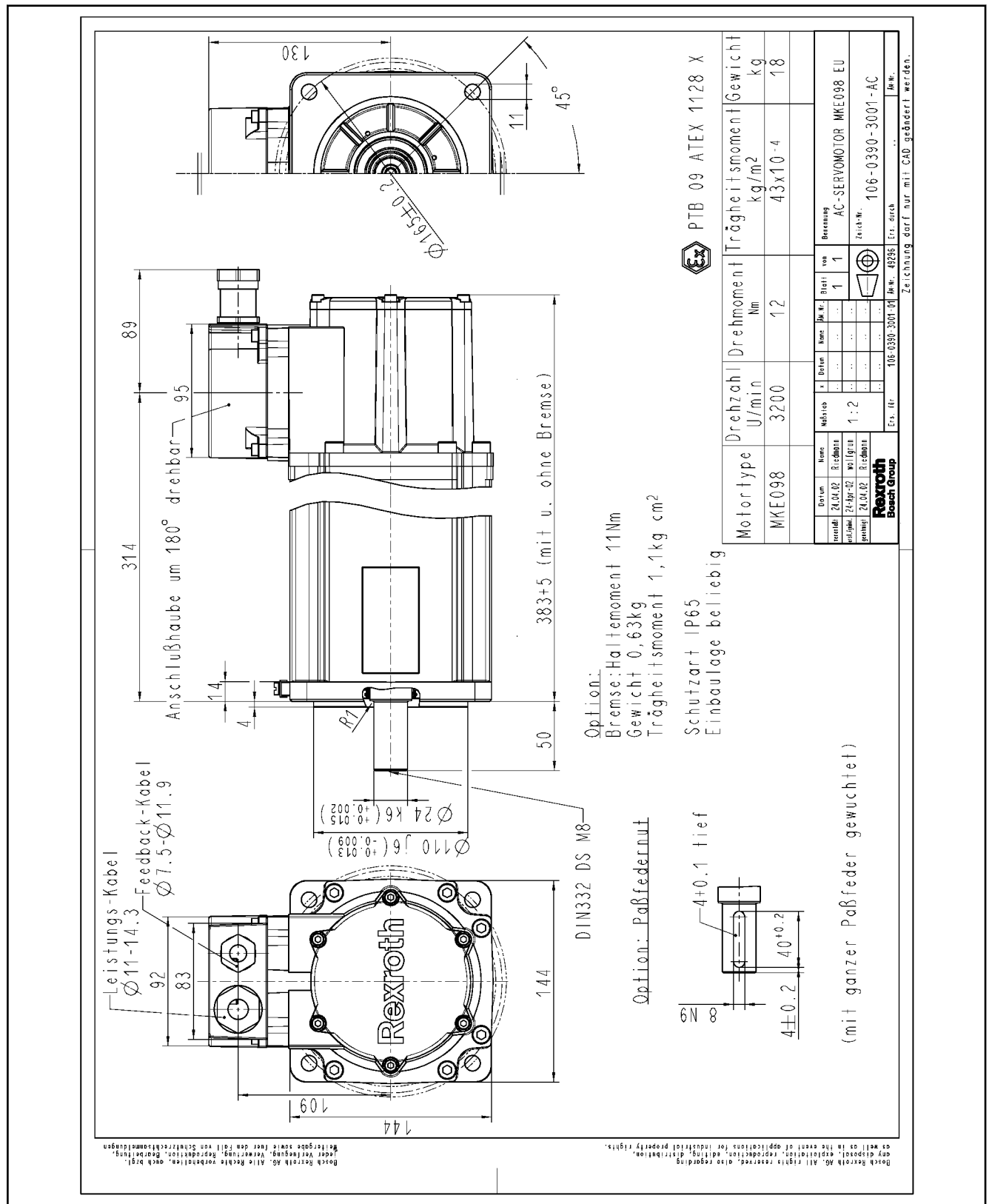

Fig.5-9: MKE098 ATEX specifications

Specifications

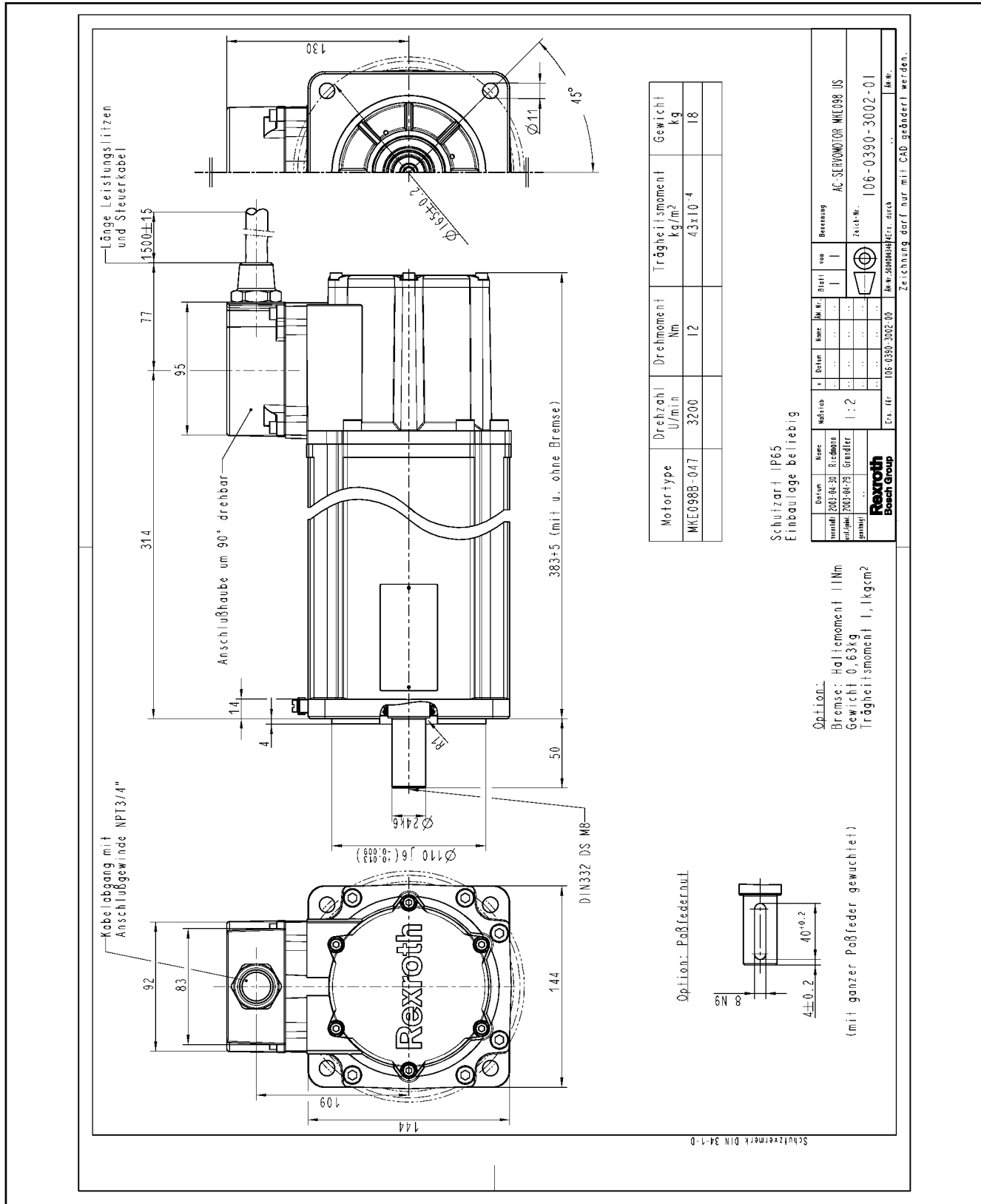

Fig.5-10: Dimensions MKE098 UL/CSA



Specifications

Shaft end

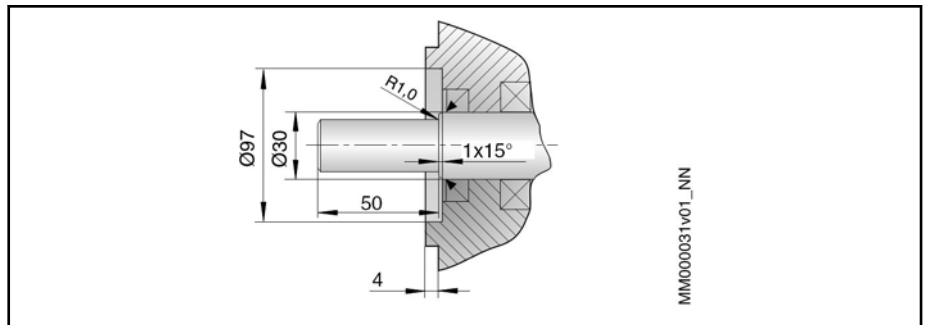

Fig.5-11: Shaft end MKE098

- Shaft end cylindrical according to DIN 748, Part 3, ed. 07.75. IEC 60072 (1971).
  - DS M5 centering hole according to DIN 332, Part 2, ed. 05.83, max. tightening torque for screw 3.0 Nm.
  - Vibration severity grade N according to DIN VDE 0530, Part 14, ed. 02.93.
- Motor Design**
- Motor design B5 according to EN 60034-7 / 1993 for all installation positions.
- Flange**
- Flange according to DIN 42948, ed. 11.65.
  - Positional accuracy with regard to true running, axial running and coaxiality to the shaft according to DIN 42955 Tolerance Class N, ed. 12.81
- Output Shaft**
- Plain shaft (preferred type)
- or
- Shaft with keyway according to DIN 6885, Sheet 1, ed. 08.68.



Caution! Balanced with key!

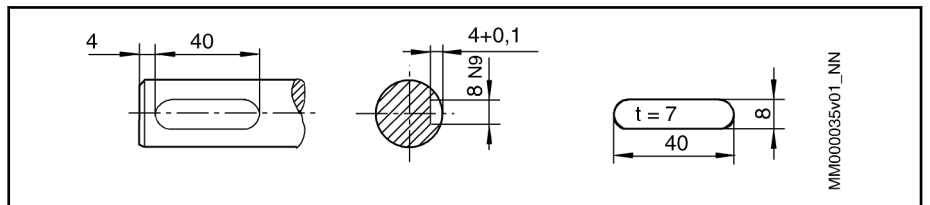

Fig.5-12: Output shaft with keyway MKE098



Pertinent key: DIN 6885-A 5 x 5 x 20; not included in the scope of delivery of the motor.

Options

For options refer to the chapter entitled "Type Code – Ordering Name".





## Specifications

## Shaft end

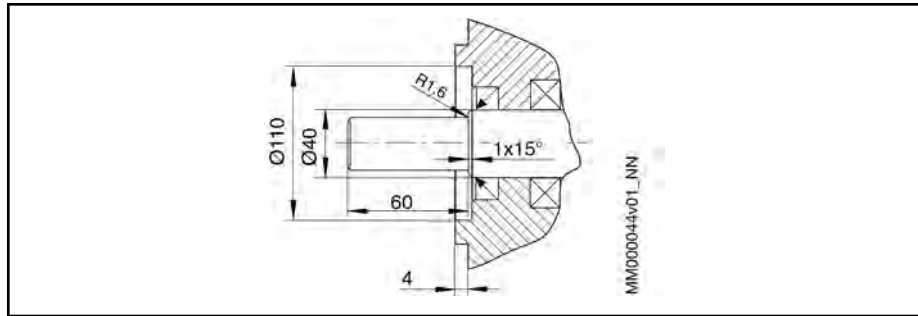

Fig.5-15: MKE118 shaft end

- Shaft end cylindrical according to DIN 748, Part 3, ed. 07.75. IEC 60072 (1971).
  - DS M10 centering hole according to DIN 332, Part 2, ed. 05.83, max. tightening torque for screw 25 Nm.
  - Vibration severity grade N according to DIN VDE 0530, Part 14, ed. 02.93.
- Motor Design**
- Motor design B5 according to EN 60034-7 / 1993 for all installation positions.
- Flange**
- Flange according to DIN 42948, ed. 11.65.
  - Positional accuracy with regard to true running, axial running and co-axiality to the shaft according to DIN 42955 Tolerance Class N, ed. 12.81
- Output Shaft**
- Plain shaft (preferred type)
- or
- Shaft with keyway according to DIN 6885, Sheet 1, ed. 08.68.



Caution! Balanced with key!

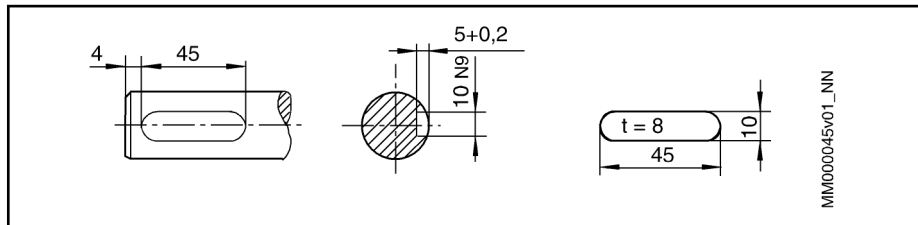

Fig.5-16: Output shaft with keyway MKE118



Pertinent key: DIN 6885-A 10 x 8 x 45; not included in the scope of delivery of the motor.

**Options** For options refer to the chapter entitled "Type Code – Ordering Name".

# 6 Type Codes

## 6.1 Description

**General information** Each order of a product by Rexroth must be based on the type code. All available motor variants are uniquely described by their type code. The individual characters of the type code (abbrev. column) and their meaning are described below.



- The chapter "Application Notes" includes detailed explanations for the separate options.
- Before ordering, please check the availability of the separate options with your Bosch Rexroth Service.

**Product group** Example: **MKE**□□□□-□□□□-□□□□-□□□□  
**MKE**, designation of Rexroth for servo motors, which are suited for use in hazardous areas.

**Motor frame size** Example: MKE**037**□-□□□□-□□□□-□□□□  
 The motor size determines important mechanical motor specifications and is proportional to the performance variables.

**Motor length** Example: MKE037**B**-□□□□-□□□□-□□□□  
 Within a series, the graduation of the increasing motor length is indicated in alphabetic order.

**Winding code** Example: MKE037B-**144**-□□□□-□□□□-□□□□  
 In connection with the motor size and motor frame length, the winding codes define the electric motor output data for all Bosch Rexroth motors.

**Motor encoder** Example: MKE037B-144-**A**□□□□-□□□□  
 MKE motors are equipped with encoder systems. To control the motor speed and / or to position the motor, the drive control device must know the current motor position. To achieve this, the integrated encoder system makes the appropriate signals available to the drive controller.

**Output shaft** Example: MKE037B-144-**AG**□-□□□□  
 To connect the machine elements to be driven to the motor drive shafts, the following options are available for MKE motors.

Option	Design	Detail
G	Plain shaft	With frontal centering hole with "DS" thread according to DIN 332, Part 2, Edition 05.83
P	Shaft with keyway <sup>1)</sup>	
<sup>1)</sup> Keyway according to DIN 6885, Sheet 1, ed. 08.68. For details, refer to the motor rating sheet!		

Fig. 6-1: Output shafts



MKE motors are balanced with the complete key. The related key is not included in the scope of delivery.

**Holding brake** Example: MKE037B-144-**AG1**-□□□□  
 As an option, MKE motors are supplied with electrically releasing holding brakes with various holding torques.

Type Codes

Option	Holding Brakes
0	Without holding brake
1, 2, 3	With holding brake

 The holding brake is not suitable for the protection of personnel or as a service brake! Please also observe the installation and safety instructions on the motor holding brakes in the chapter entitled "Application Notes".

Output direction of power connector

Example: MKE037B-144-AG1-B□□□

The cable outlet direction of the motors will be delivered as ordered. For housing types "E", only the output direction B is available.

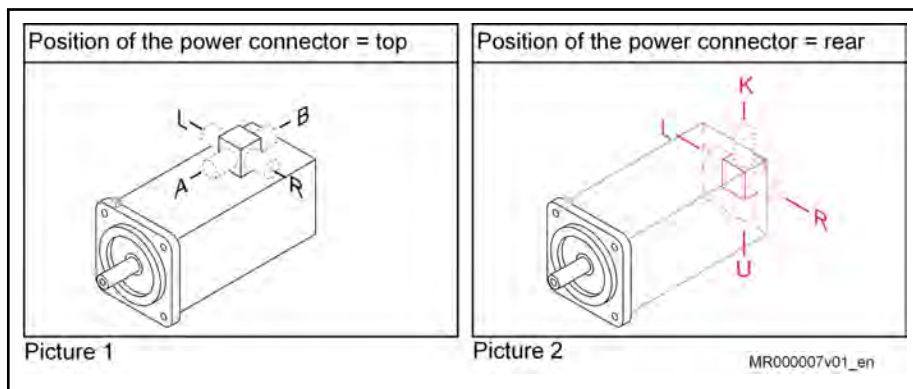

Picture 1 MKE037, -047, -098

Picture 2 MKE118

Fig.6-2: Position of the power connector for motors MKE

Housing Type

Example: MKE037B-144-AG1-BE□□

Option	Housing Type	Remark
E	According to European Standard (EN), Insulation system is UL certified	Only output direction "B" or "K"
U	According to American Standard (UL)	-

Fig.6-3: MKE housing type

Other design / wire routing (diameter)

Example: MKE037B-144-AG1-BENN

For options and availability see type code.

Reference to Standards

Notes on quoted standards in the type code (e.g. DIN, EN, ISO or factory standards). The version listed is always that valid at the time the type code is issued.

Remark

The "Comment" section provides information required for handling the type code. This includes, for example, descriptions on footnotes or notes on availability.











## 7 Accessories and Options

### 7.1 Motor Encoder

To control the motor speed and / or to position the motor, the drive control device must know the current motor position.

To achieve this, the integrated encoder system makes the appropriate signals available to the drive controller. The drive decives are capable of transmitting the positional value thus determined to a superordinate CNC or SPS.

#### Encoder Data Memory

The encoder electronics is equipped with a data memory where the motor type name, the control loop parameters and the motor parameters are filed. The drive controllers read out this data. This ensures

- quick and easy startup,
- adaptation between the motor and the drive control device without the risk of damage to the motor.

For available encoder variants for MKE motors [chapter 4.3 "Technical Data Encoder for MKE Motors" on page 28](#).

Accessories and Options

## 7.2 Holding Brakes

The holding brake serves to hold the axis, when the machine is in the de-energized state. The holding brakes are allowed to be used in **normal operation** and in standstill and at an **EMERGENCY STOP** only to deactivate an axis ( $n < 10 \text{ min}^{-1}$ ).

**When using holding brakes, observe the additional information in [chapter 9.12 "Holding Brakes \(Ex\)" on page 90](#).**



For technical data and availability of holding brakes see chapters "Technical Data" and "Type Codes".

---

## 7.3 Gearboxes

---

**⚠ DANGER**

**Explosion hazard! Fatal injuries, damage to the building and installation.**

A motor-gearbox combination must comply with the explosion protection requirements according to the ATEX directive 94/5EC.

---

Rexroth does not offer or supply servo-planetary gears according to ATEX for the attachment to MKE-ATEX motors, neither separately nor attached to motors.

Please contact the following manufacturer recommended by Rexroth, if necessary:

Neugart GmbH

Keltenstr. 16

77971 Kippenheim, Germany

Phone: +49(0)7825-847-0

Fax: +49(0)7825-847-102

Internet: <http://www.neugart.de>



## 8 Connection Technique

### 8.1 Variants

MKE motors are available in:

- Housing design **E** (acc. to European standard EN)
- Housing design **U** according to American Standard (UL)

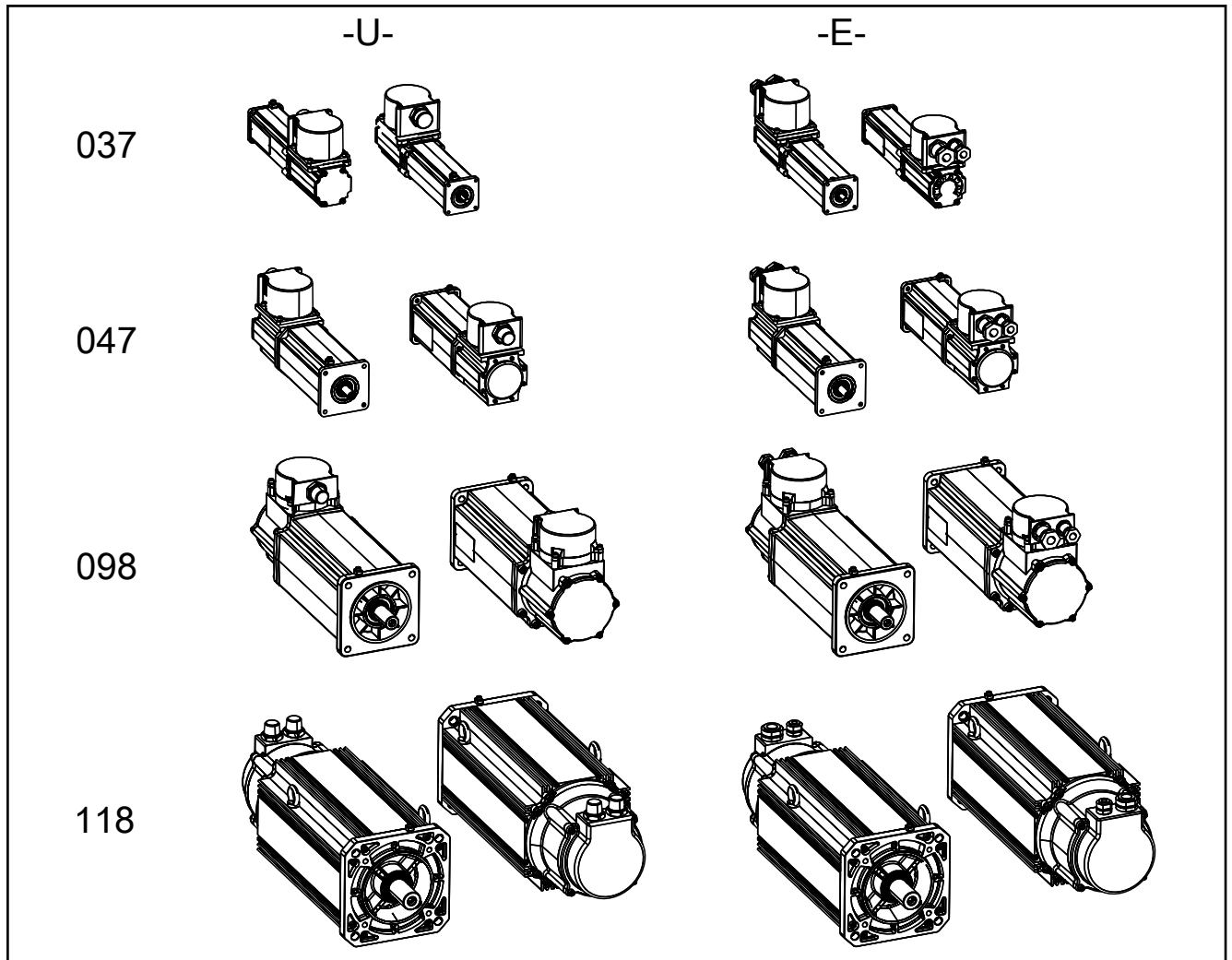

Fig.8-1: Overview MKE motors, housing design E, U

The different regulations of the responsible public authority require the subsequent shown connection variants.

## Connection Technique

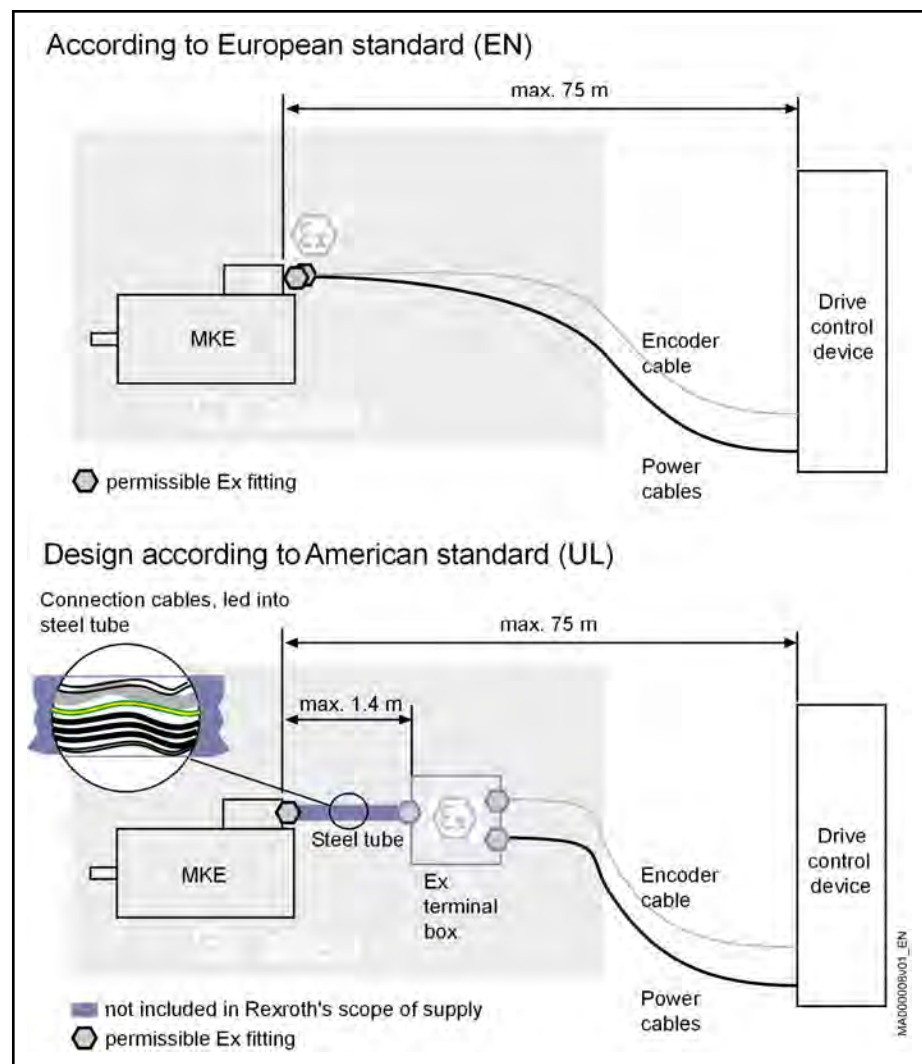

Fig.8-2: Connection variants MKE motors

## Connection temperature control

The analysis of the motor temperature has to be done at Rexroth when MKE motors are used in hazardous areas via IndraDrive drive controllers.

The connection of the PTC-resistors for the motor temperature analysis is shown in the particular interconnection diagrams of the drive controllers.

**⚠ DANGER**

**Danger of explosion by improper temperature rise due to wrong temperature analysis!**

⇒ The temperature analysis of the motors **must** be done with drive-devices of Rexroth!

⇒ The connections [1] and [2] of the PTC-resistors must be connected with the temperature monitoring of the drive controller!

The maximum permitted surface temperature of MKE motors is  $\leq 135^\circ$ . This corresponds to the temperature class T4 acc. to EN 60079-0: 2009. The PTC-resistors mounted into the MKE motors assure a reliable and safe over-temperature shutdown, in connection with the decoding circuitry of the drive controllers.

## Ground terminal connection

The connection of the ground terminal is to be made over the leaded ground terminal within the power cable into the terminal box of the motor.



Connection Technique

**Additional grounding connection**

An additional grounding connection according to EN 60079-0: 2009 is required for MKE motors. All MKE motors have to be grounded over the additional connection part (ground terminal clamp on the motor flange).

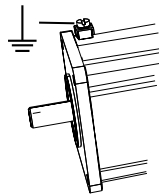

Motor	Terminal range	max. tightening torque
MKE037	4.0 mm <sup>2</sup> finely stranded up to 6.0 mm <sup>2</sup> single-wire	2.0 Nm
MKE047		
MKE098		
MKE118		

Fig. 8-3: Additional grounding connection

**Temperature Resistance of Connection Cables**

For using the MKE motors in explosive areas, cables with a temperature resistance of min. **80°C (176° F)** have to be used.



The cables of Rexroth, stated in the selection lists comply with this condition precedent.

**Ready-made Connection Cables**

Ready-made connection cables in various length for motors according to European Standard "E" can be ordered at Bosch Rexroth.

Motors according to American Standard "U" are delivered with a 1.7 m long connection cable. The motors must be connected according to UL674\*ANSI 674 by the user.

Selection lists of all available connection cables [chapter 15.2 "Selection of Connection Cable" on page 127](#)

Additional Documentation

**DOK-CONNEX-CABLE\*INDRV-CAxx-EN-P**

## Connection Technique

## 8.2 Motor Connection According to European Standard (EN)

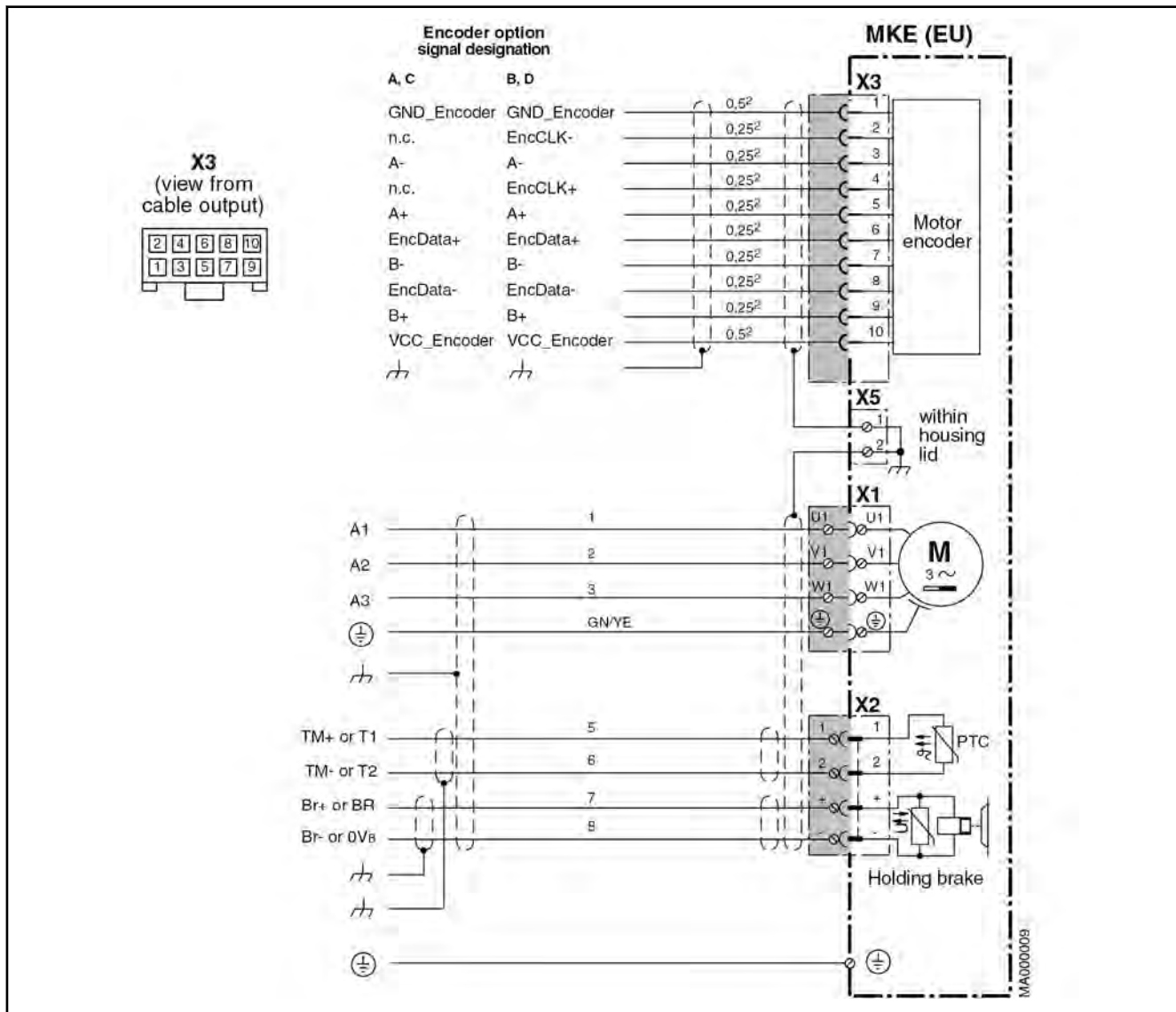

Fig. 8-4: Connection overview MKE according to European standard

**Power and encoder connection**

The power and encoder cables of the MKE motors acc. to European Standard have to be lead with the EExd cable duct into the terminal box and have there be connected with the plug-connector and the screw-terminal.

### 8.3 Connection According to American Standard (UL)

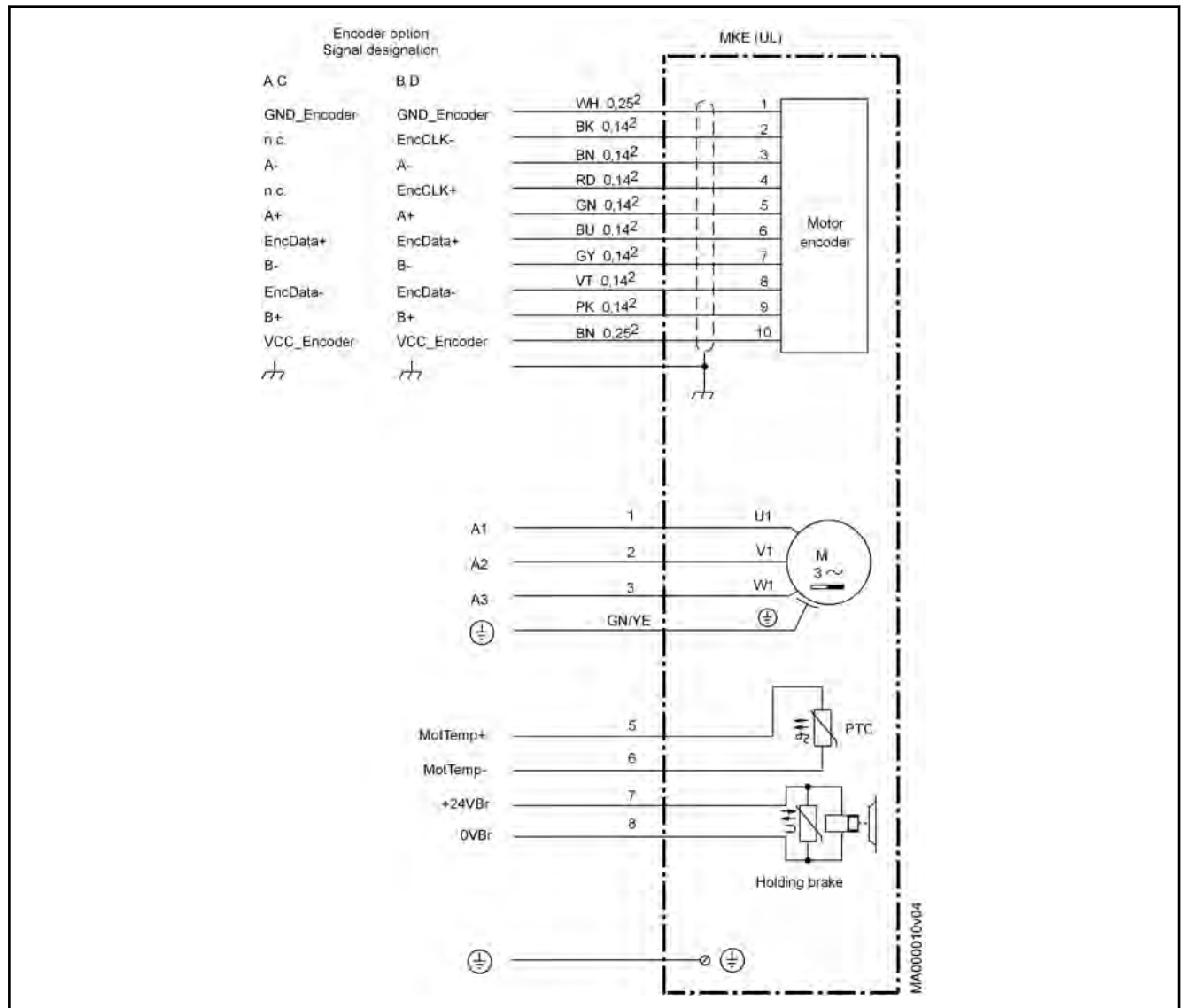

Fig. 8-5: Connection overview according to American standard

**Power and encoder connection**

The connection cables of the MKE motors according to American standard are to be performed through a cast cable duct into the motor. The 1.7 m long connection cables has to be performed through a 3/4 inch metall pipe into an allowed Ex-terminal box [fig. 8-2 " Connection variants MKE motors" on page 70](#), by the user. Standard connection cables lead from an Ex terminal box to a drive-device.



## 9 Operating Conditions and Application Notes

### 9.1 Permitted Areas of Use for MKE Motors

#### 9.1.1 Motors with Housing Design "E"



Motor	Test number ATEX	Designation / suitable for	Standard	UL File number
MKE037	PTB 09 ATEX 1128 X	 II 2G Ex d IIB T4 Gb X or  II 2D Ex tc IIIC T135 °C Dc IP6X X Zone 1, 2, 21, 22	EN 60079-0:2009	E163211
MKE047			EN 60079-1:2007	
MKE098			EN 60079-31:2009	
MKE118	PTB 09 ATEX 1127 X			

Fig.9-1: Areas of Use for MKE Motors with Housing Design "E"



- (1) Hazardous area with explosion protected apparatus
- (2) Control cabinet
- (3) Drive controller
- (4) MKE motor
- (5) Connections
- (6) Motor power cables
- (7) Encoder Cables

Fig.9-2: Hazardous area - standard (EU)

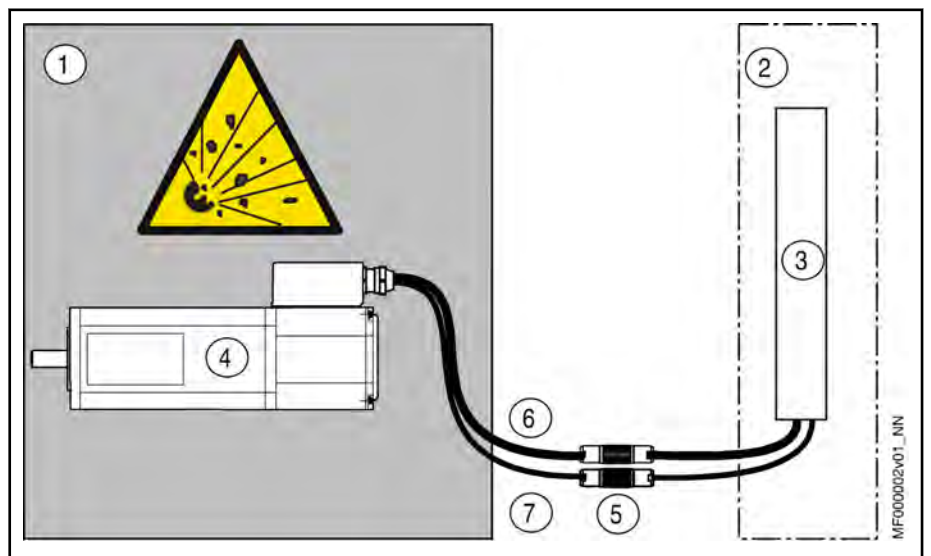
The respective drive devices and connections of the connection cables (power and encoder connection) must lay outside of the hazardous area.

## Operating Conditions and Application Notes

## 9.1.2 Application Conditions ATEX Device Group II, Category 2

**⚠ DANGER****Danger of explosion and life or high damage to property!**

All used **components and accessory parts** must fulfill the requirements for explosion protection according to the 94/9/EG directive.

The **conditions on use** given in this documentation must be taken into account for any project planning and be observed during operation.

**Notes about test number**

The EC type test certificate number for MKE motors is designated by the "X" in the declaration of conformity and on the type plate. This identification is a note about special conditions, which have to be observed with regard to the specified safety and medical requirements of this underlying standards. Please observe the following special conditions for a safe operation of the motors in your construction:

- The allowed ambient temperature is 0 ... 40 °C.
- The gap width and length acc. to EN 60079-1:2009, table 1 were exceeded or fall below to ensure the higher requirements of the UL 674. A repair acc. to the values of table 1 in EN 60079-1 is not allowed.
- Maintenance and repair of motors have to be done by Rexroth service.
- Use screws with a minimum property class of 8.8 to fasten the pressurizing room (housing, terminal box, ...).
- Only such components for assembly and disassembly (cables and cable entries, connecting parts, bulk head connectors, ...) are allowed, which correspond technically to the standards EN 60079-0:2009, EN 60079-15:2010, EN 60079-31:2009, which are suitable for the conditions of use and have a special certificate.

**Maximum housing temperature**

The maximum housing temperature is 115 °C on the motor housing at an ambient temperature of 40 °C. The ignition temperature of materials which come into contact with the motors must not come under 135 °C.

**Connection Conditions**

The motors are only allowed to operate with the Rexroth drives IndraDrive, ECODRIVE, DURADRIVE and DIAX04. Drive control devices of other manufacturers are not permitted.

**Grounding**

Speed-controlled drive systems create discharge currents. For this reason the motors have to be grounded over the motor cable and over a second separate ground wire with a minimum cross section of **4 mm<sup>2</sup>**. Check that the position of the grounded conductor is fixed before commissioning.

**Corrosion**

Corrosion of the motor housing by aggressive materials (such as certain coolants, lubricants, cutting oils or salt mists) must be prevented.

**Emergency stop**

Stored energies in the drive controller must be removed or isolated as quickly as possible when the **emergency stop device** is actuated to ensure that the risk or an effect into the danger zone is reduced in the event of a failure (ATEX directive 94/9/EC, appendix II, chapter 1.6.2)

The user has the following possibilities:

- Energy isolation is guaranteed from the exit of the drive device, if at emergency stop, in addition to the power loss of the drive device is locked electronically. This results from line contactor-shutdown with subsequent failure reaction of the drive device because of power failure (cp. F281). Adjusting the required drive-end failure reaction must be made by the user at the drive device via the drive parameters (cp. P-0-0119) according to the functional description.

## Operating Conditions and Application Notes

- To have the encoder feeder cable also de-energized, shutdown the control voltage of the drive device.

Are the control voltage and the power of the drive device shutdown, the exit on the motor side has electronically locked itself over the output stage and eventually stored energies in the intermediate direct current link are therewith isolated on the motor side and on the output side.



- The intermediate direct current link short-circuit can be used – if possible – to reduce the energies within the intermediate direct current link of the drive device after shutdown of supply voltage fast.

Independent from these possibilities, the user has to check – as stipulated in the safety notes - with a suited measuring instrument, in general, before working on the machine, if the machine or parts of it, are under residual voltage (e.g. caused by rest energy of capacitors in filters and drive devices etc.). Wait for their discharging time.

**Fan** Operation of motors according to the ATEX Directive 94/9/EG is only allowed **without** a fan.

## Operating Conditions and Application Notes

## 9.1.3 Motors with Housing Design "U",

Motor	UL File number	Designation / suitable for	Standard
MKE037	E203009	 LISTED Class I Division 1 Groups C, D <sup>1)</sup>	UL 508C/1996-11
MKE047			UL 674/1994-04
MKE098		 LISTED Class I Division 1 Groups C, D; Class II Division 1 Groups F, G <sup>1)</sup>	UL 1446/1997-05
MKE118			

1) Operation with Rexroth controllers DKCx.3, HDD, HDS, HMS, HMD, HCS

Fig.9-3: Areas of Use for MKE Motors with Housing Design "U"

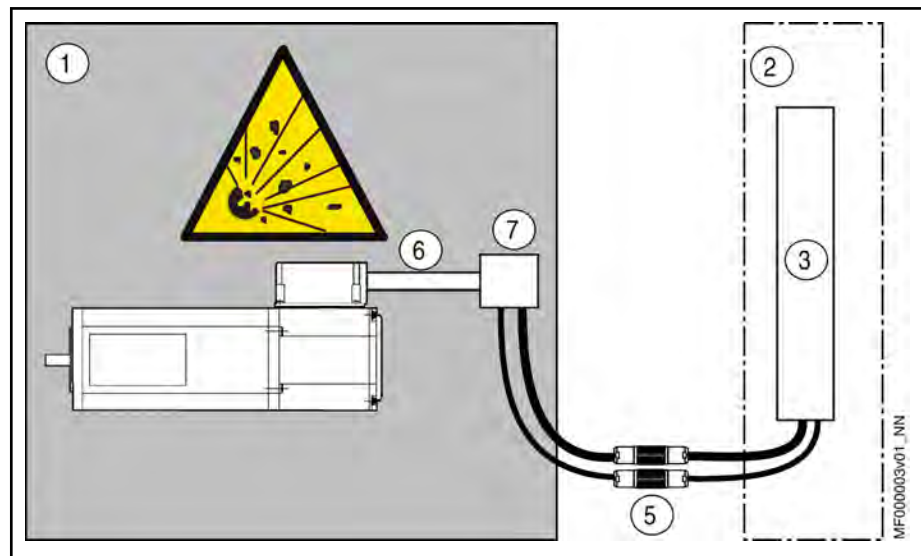

- (1) Hazardous area with explosion protected apparatus
- (2) Control cabinet
- (3) Drive controller
- (4) MKE motor
- (5) Connections (optional)
- (6) Connection cables in a steel pipe (not in the scope of delivery)
- (7) Ex-terminal box (not included in scope of delivery)

Fig.9-4: Hazardous area - standard (UL)



## 9.2 Installation Altitude and Ambient Temperature

**Nominal data** The motor performance data specified are applicable for

- Ambient temperatures from 0° ...+40°C
- Installation altitude of 0 ... 1,000 m above sea level.

**Exceeding the nominal data** MKE motors are certified by the regulation office for the temperature range 0° ... +40° C. Any deviations repeal the certification. Please contact your responsible sales office, if you use the motors outside the specified area of use. They can give you some recommendations for special certifications.

## 9.3 Degree of Protection

The degree of protection is specified by the **IP-Code**. The code consists of the abbreviation IP and two characteristic numbers describing the degree of protection.

The **first digit** defines the degree of protection against contact and penetration of foreign particles. The **second digit** defines the degree of protection against water.

1st digit	Degree of protection
6	Protection against penetration of dust (dust-proof); complete contact protection
2nd digit	Degree of protection
5	Protection against a water jet from a nozzle directed against the housing from all directions (jet water)

Fig.9-5: IP types of protection



The second characteristic number defines the degree of protection against water. If cleaning is effected using high pressure and/or solvents, coolants, or penetrating oils, it might be necessary to select a higher degree of protection.

Motor area	Degree of Protection	Remark
Motor housing, drive shaft, power and encoder connections (only for correct assembly)	IP 65	Standard design

Fig.9-6: IP protection mode MKE motors (EN 60034-5)

## 9.4 Compatibility with Foreign Materials

All Rexroth controls and drives are developed and tested according to the state of the art.

However, since it is impossible to follow the continuing further development of every material with which our controls and drives could come into contact (e.g. lubricants on tool machines), reactions with the materials that we use cannot be ruled out in every case.

For this reason, you must execute a compatibility test between new lubricants, cleansers, etc. and our housings and device materials before using these products.

## Operating Conditions and Application Notes

## 9.5 Design and Installation Positions

Motor design B05		
IM B5	IM V1	IM V3
		
Flange attachment on the drive side of the flange	Flange attachment on the drive side of the flange, drive side facing down	Flange attachment on the drive side of the flange, drive side facing up

Fig.9-7: Permissible conditions of installation according to EN 60034-7:1993

### NOTICE

### Motor damage due to penetration of liquids!

If motors are attached according to IM V3, fluid present at the output shaft over a prolonged time may penetrate and cause damage to the motors.

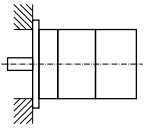
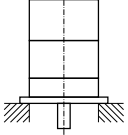
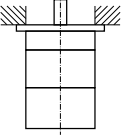
Ensure that fluid cannot be present at the output shaft.

## 9.6 Motor Paint

Color Black (RAL9005)

Resistance Resistant against

- diluted acids and lyes
- water, seawater, sewage
- current mineral oils

Resistant to a limited degree against

- organic solvents
- hydraulic oil

Not resistant against

- concentrated acids/lyes

It is not allowed to repaint ex-type motors of MKE series to ensure that there will be no negative effects on surface properties (e.g., insulation resistance, electrostatic charging).

## 9.7 Vibration

### Sinusoidal Vibrations

Vibrations are sine-wave oscillations in stationary use, which vary in their effect on the resistance of the motors depending on their intensity.

Based on DIN EN 60721-3-3 and DIN EN 60068-2-6, the following values result for Rexroth motors:

## Operating Conditions and Application Notes

Direction	Maximum permissible vibration load (10-2,000 Hz) for MKE motors with subject to encoder design			
	A	B	C	D
Axial	10 m/s <sup>2</sup>		10 m/s <sup>2</sup>	
Radial	30 m/s <sup>2</sup>		10 m/s <sup>2</sup>	

Fig.9-8: Permissible vibration load for MKE motors

## 9.8 Shock

The shock load of the motors is indicated by providing the maximum permitted acceleration in non-stationary use, such as during transport.

Function-impairing effects are avoided as long as the limits specified are kept.

Based on DIN EN 60721-3-3 and DIN EN 60068-2-6, the following values result for Rexroth motors:

Frame size	Maximum allowed shock load (6 ms)	
	Axial	Radial
MKE037	10 m/s <sup>2</sup>	1,000 m/s <sup>2</sup>
MKE047		
MKE098	10 m/s <sup>2</sup>	300 m/s <sup>2</sup>
MKE118	10 m/s <sup>2</sup>	200 m/s <sup>2</sup>

Fig.9-9: Permitted shock load for MKE motors

## 9.9 Output Shaft

### 9.9.1 Plain Shaft

The standard design recommended for MKE motors provides a non-positive shaft-hub connection without play and excellent running smoothness. Use clamping sets, clamping sleeves or clamping elements to couple the machine elements to be driven.

### 9.9.2 Output Shaft with Keyway

The optional key according to DIN 6885, sheet 1, version 08-1968, permits the form-fitting transmission of torques with constant direction, with low requirements for the shaft-hub connection.

## Operating Conditions and Application Notes

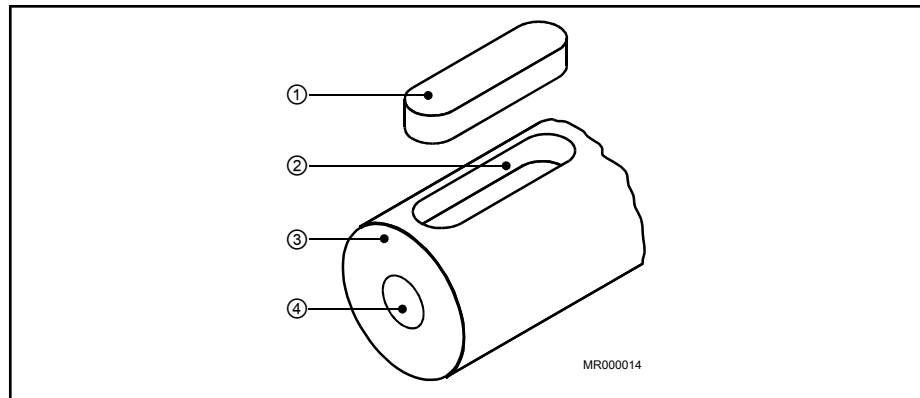

- ① Key
- ② Keyway
- ③ Motor shaft
- ④ Centering hole

Fig.9-10: MKE Output shaft with key

The machine elements to be driven must additionally be secured in the axial direction via the centering hole on the end face.

### NOTICE

#### Damage to property due to reversing mode!

Shaft damage! In case of intense reversing operation, the seat of the fitting spring may deflect. Increasing deformations can lead to a break of shaft.

Preferably, use plain output shafts.

#### Balancing with a Complete Key

MKE motors are balanced with the **complete** key. Hence, the machine element to be driven must be balanced without a key.

Modifications to keys may be made only by the user himself and on his own responsibility. Bosch Rexroth does not assume any warranty for modified keys or motor shafts.

## 9.9.3 Output Shaft with Shaft Sealing Ring

MKE motors are designed with according to DIN 3760 – design A.

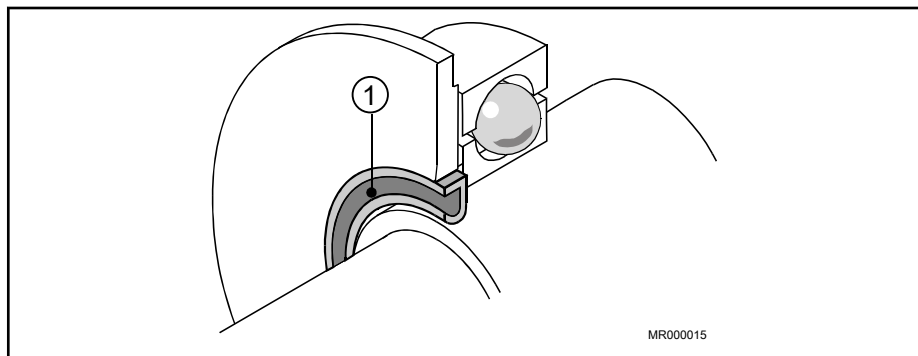

- ① Radial shaft sealing ring
- Fig.9-11: MKE motors radial shaft sealing ring

**Wear** Radial shaft sealing rings are friction seals. Hence, they are subject to wear and generate frictional heat.

Wear of the friction seal can be reduced only if lubrication is adequate and the sealing point is clean. Here, the lubricant also acts as a coolant, supporting the discharge of frictional heat from the sealing point.

## Operating Conditions and Application Notes

- Prevent the sealing point from becoming dry and dirty. Make sure everything is clean.



Under normal environmental conditions, the shaft seal is greased for its lifetime. Under unfavorable environmental conditions (e.g. grinding dust, metal shavings), however, maintenance intervals could be necessary.

---

**Resistance**

The materials used for the radial shaft sealing rings are highly resistant to oils and chemicals. The performance test for the particular operating conditions lies, however, within the machine manufacturer's responsibility.



The complex interactions between the sealing ring, the shaft and the sealing fluid, as well as the particular operating conditions (frictional heat, soiling, etc.), do not allow calculation of the lifetime of the shaft sealing ring.

**Vertical Installation Positions  
IM V3**

The degree of protection on the flange side of motors with a shaft sealing ring is IP 65. Hence, tightness is ensured only in case of splashing fluids. Fluid levels present on the A-side require a higher degree of protection. For vertical installation position (shaft at the top) of the motor, please observe the additional notes in [chapter 9.5 "Design and Installation Positions" on page 80](#).



Rexroth recommends that any direct contact of the drive shaft and the radial shaft sealing ring with the processing medium (coolant, material corrosion) caused by the machine or system construction be avoided.

---

## Operating Conditions and Application Notes

## 9.10 Bearings and Shaft Load

## 9.10.1 Radial Load, Axial Load

During operation, both radial and axial forces act upon the motor shaft and the motor bearings. The construction of the machine, the selected motor type and the attachment of driving elements on the shaft side must be adapted to one another to ensure that the load limits specified are not exceeded.

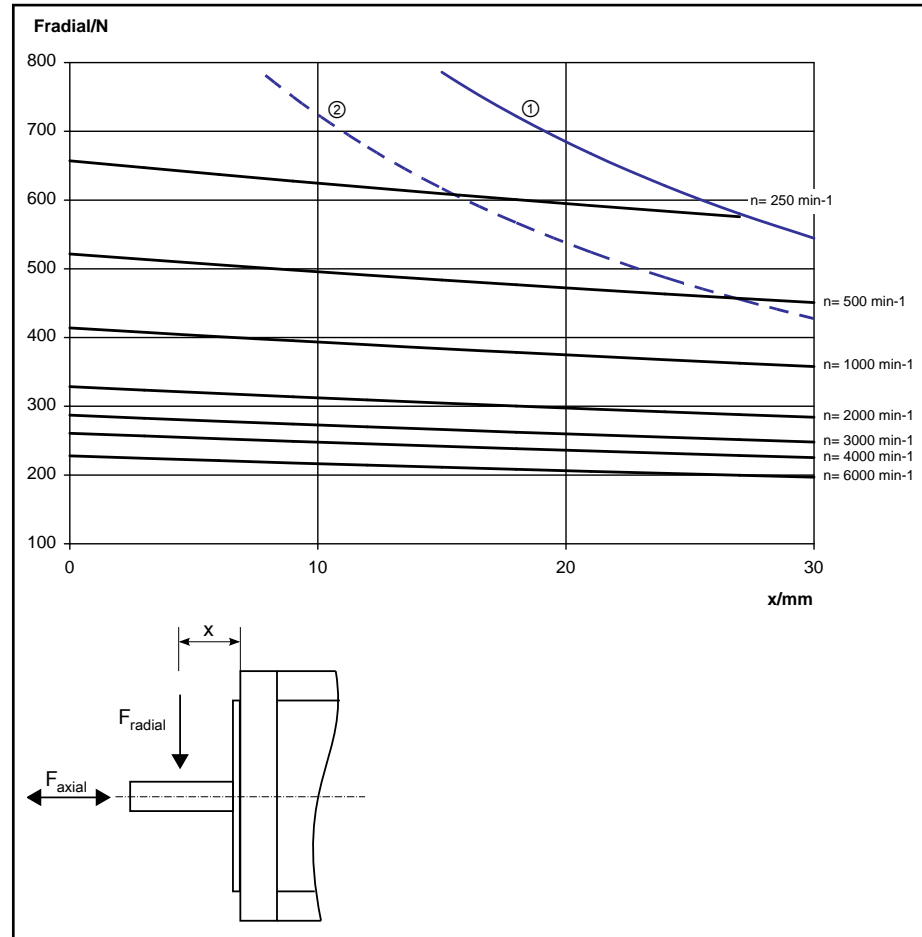

X	Distance point of force application
$F_{\text{radial}}$	Permittable radial force
$F_{\text{axial}}$	Permittable axial force
①	Limiting curve maximal radial force for smooth output shaft
②	Limiting curve for maximum radial force for output shaft with keyway
$n = \text{xxxx} \text{ min}^{-1}$	Characteristic curve of maximum radial force for specified average speed $n_m$

Fig.9-12: Example shaft load diagram

**Maximum allowed radial force** The maximum permissible radial force  $F_{\text{radial\_max}}$  depends on the following factors:

- Shaft-breaking load
- Shaft design (plain; with keyway)

**Allowed radial force** The permitted radial force  $F_{\text{radial}}$  depends on the following factors:

- Arithmetically averaged speed ( $n_{\text{mean}}$ )
- Force action point x
- Bearing service life

Operating Conditions and Application Notes

**Allowed axial force** The maximum permissible axial force  $F_{axial}$  is indicated in the section on the radial force.

**Mean speed** If the mean speed is calculated according to the following equation, the acceleration and deceleration times are taken into account.

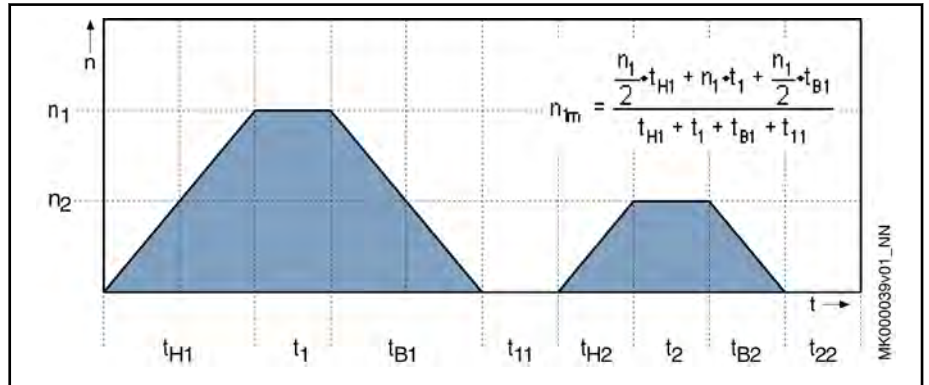

- $n_{1m}; n_{2m}$  Average speed section
- $n_1; n_2$  Machining speed
- $t_{H1}; t_{H2}$  Acceleration time
- $t_1; t_2$  Machining time
- $t_{B1}; t_{B2}$  Deceleration time
- $t_{11}; t_{22}$  Standstill time

Fig.9-13: Mean speed

A complete processing cycle can consist of several sections with different speeds. In this case, the average must be calculated from all sections.



The initialization and braking times can be ignored in the calculation if the time in which the drive is operated at a constant speed is significantly greater than the acceleration and deceleration time.

Operating Conditions and Application Notes

9.10.2 Shaft Load MKE Motors

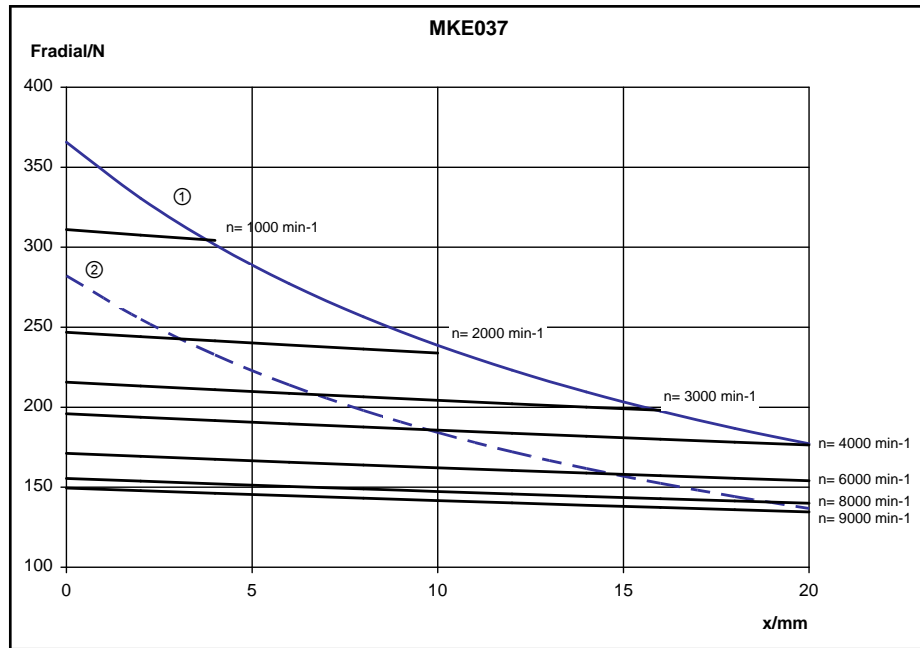

- ① Shaft, plain
- ② Shaft with keyway

Fig.9-14: MKE037: permissible radial force (shaft and bearing load)

MKE037: Axial force not permitted.

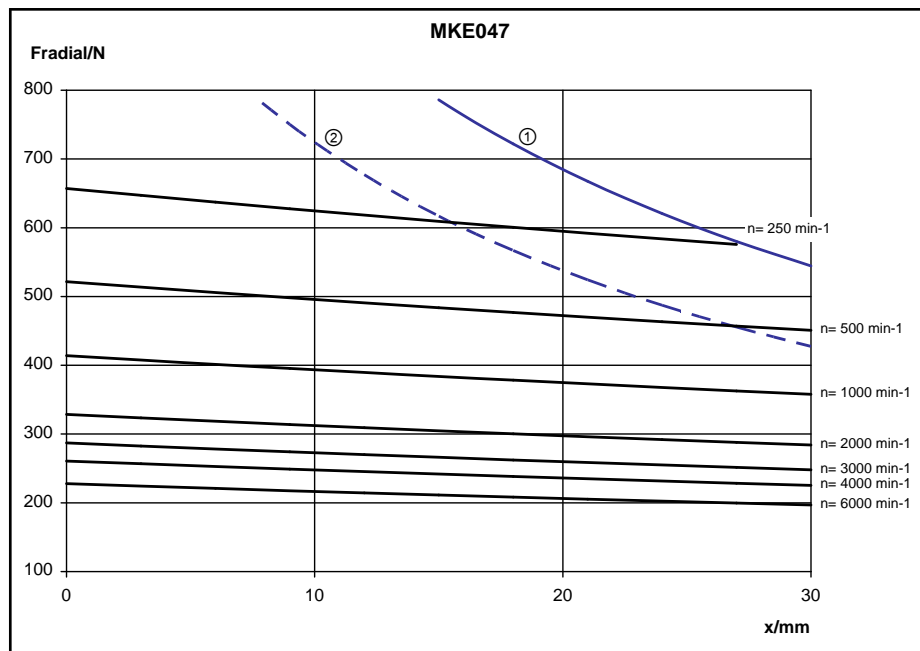

- ① Shaft, plain
- ② Shaft with keyway

Fig.9-15: MKE047: permissible radial force (shaft and bearing load)

MKE047: Permissible Axial Force 30 Nm.



Operating Conditions and Application Notes

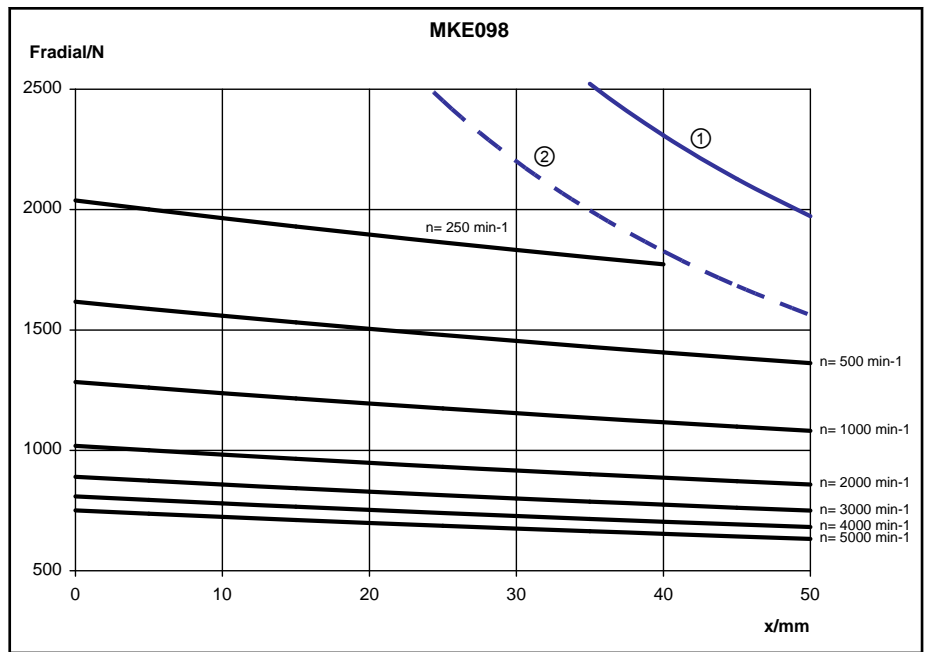

- ① Shaft, plain
- ② Shaft with keyway

Fig.9-16: MKE098: permissible radial force (shaft and bearing load)

**MKE098:Permissible Axial Force 60 Nm.**

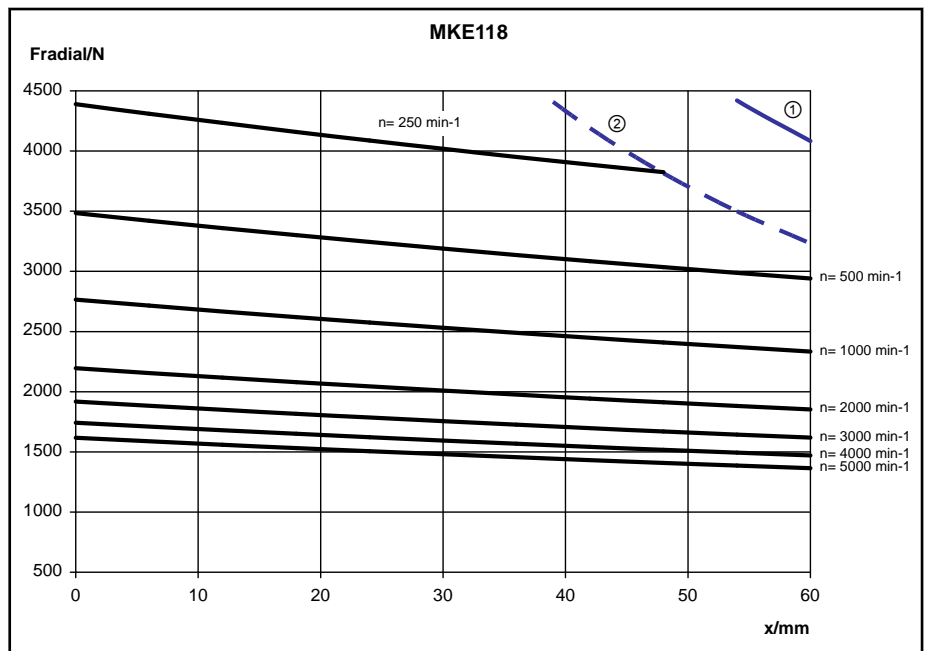

- ① Shaft, plain
- ② Shaft with keyway

Fig.9-17: MKE118: permissible radial force (shaft and bearing load)

**MKE118:Permissible Axial Force 200 Nm .**

## Operating Conditions and Application Notes

### 9.10.3 Bearing Lifetime

The bearing lifetime is an important criterion for the availability of motors. When the lifetime is considered, the "mechanical lifetime" of bearing components and materials is differentiated from the "grease lifetime" of the bearing lubricant.

If motors are operated within the limits specified for radial and axial loads, the mechanical service life of the bearings is as follows:

#### Mechanical lifetime of bearings

$L_{10h} = 30000$  operating hours

(calculated according to ISO 281, ed. 12/1990)

This applies to all MKE motors based on the following:

- The permitted loads from the corresponding chapter "Technical Data" are never exceeded.
- The motor is operated under the permitted conditions for use and in the permitted ambient temperature range of 0 °C to +40 °C.

#### Different loads may have the following effects:

- Premature failure of the bearing due to increased wear or mechanical damage.
- Reduction of the grease lifetime leads to premature failure of the bearing.
- Avoid exceeding the load limits.

#### Mechanical Bearing Lifetime in case of Increased Radial Force

Otherwise, the service life of the bearing is reduced to:

$$L_{10h} = \left( \frac{F_{radial}}{F_{radial\_ist}} \right)^3 \cdot 30000$$

$L_{10h}$  Bearing service life (according to ISO 281, Version 12/1990)

$F_{radial}$  Determined allowed radial force in N (newton)

$F_{radial\_act}$  Actually acting radial force in N (newton)

*Fig. 9-18: Calculating the bearing service life  $L_{10h}$  if the allowed radial force  $F_{radial}$  is exceeded*



The actually acting radial force  $F_{radial\_act}$  may never be higher than the maximum allowed radial force  $F_{radial\_max}$ .

## 9.11 Attaching Drive Elements

Whenever attaching drive elements to the output shaft, such as

- gearboxes
- couplings
- gear pinions

it is imperative that the following notes are observed.

### Gearbox mounting on motors

Are gearboxes mounted on motors, the thermal coupling of the motors on machines or constructions changes.

Depending on the gearbox type, the heat development on the gearbox is different. The heat dissipation of the motor via the flange is reduced in every case when a gearbox is mounted. This must be heeded at the project planning.

A reduction of the given performance data is necessary, to do not overload motors when using gearboxes.

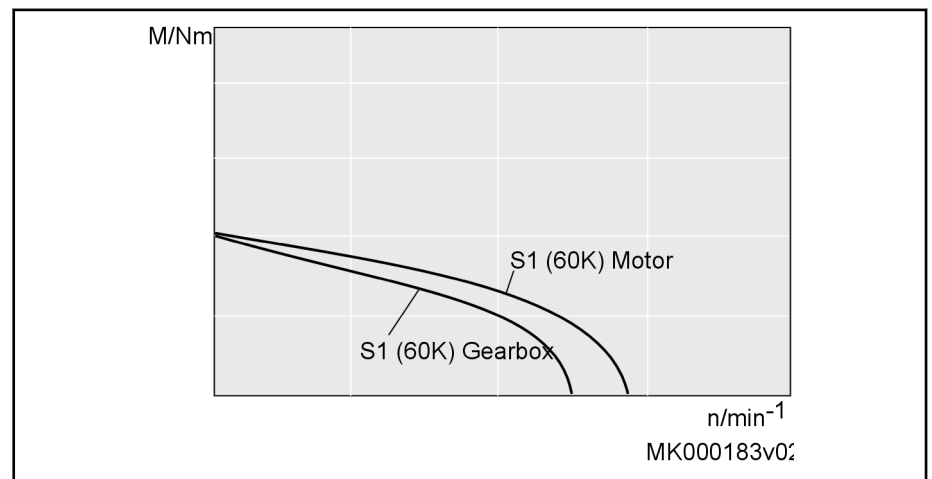

Fig.9-19: S1 characteristic curve of gearboxes



The indicated torques in the characteristic curves of the motor have to be reduced by 10-20% when mounting gearboxes.

Please, heed all further notes and specifications within this documentation for the used gearboxes.

### Overdefined bearing

Generally, redundant bearings are to be avoided by all means when connecting drive elements. The tolerances inevitably present in such cases will lead to additional forces acting on the bearing of the motor shaft and, as the case may be, to a distinctly reduced service life of the bearing.



If redundant attachment cannot be avoided, it is absolutely necessary to consult with Bosch Rexroth.

### Couplings

The machine construction and the drive elements used must be carefully adapted to the motor type so as to make sure that the load limits of the shaft and the bearing are not exceeded.



When extremely stiff couplings are attached, the radial force which constantly changes the angular position may cause an impermissibly high load on the shaft and bearing.

## Operating Conditions and Application Notes

**Ball bearing pinion or helical drive pinion**

Owing to thermal effects, the flange-sided end of the output shaft may shift by 0.6 mm in relation to the motor housing. If helical drive pinions or bevel gear pinions directly attached to the output shaft are used, this change in position will lead to

- a shift in the position of the axis, if the driving pinions are not defined axially on the machine side,
- a thermally dependent component of the axial force, if the driving pinions are defined axially on the machine side. This causes the risk of exceeding the maximum permissible axial force or of the play within the gears increasing to an impermissible degree.



In such cases, you should therefore preferably use drive elements with their own bearings which are connected to the motor drive shaft via axially compensating couplings.

## 9.12 Holding Brakes (Ex)

### 9.12.1 Holding Brake Electrically-Released

The holding brake of the IndraDyn S motors works according to the principle "electrically-released". Non-operative closed holding brakes open when applying the operating voltage.

The voltage supply of the holding brake has to be designed so as to guarantee under the worst installation and operation conditions that a sufficient voltage ( $24\text{ V} \pm 10\%$ ) is available at the motor in order to release the holding brake.

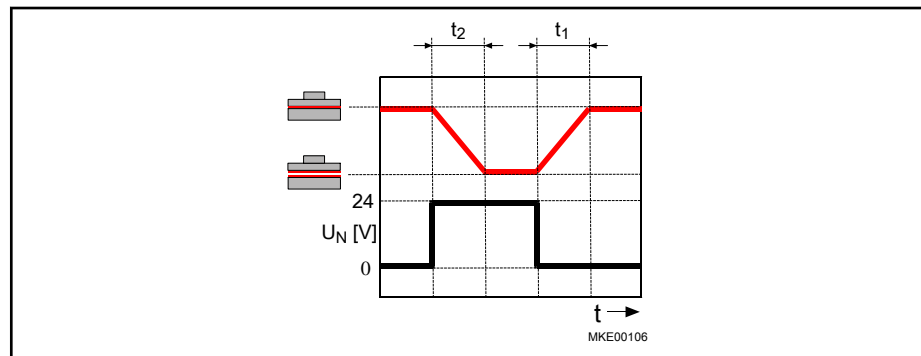

$t_1$  Connection time  
 $t_2$  Disconnection time

Fig. 9-20: Switching status of holding brake over time

The electrically releasing holding brake is used to hold the axes at a standstill and when the "controller enable" signal is off. When the supply voltage fails and the controller is enabled, the electrically-releasing holding brake will close automatically.



Do not use the holding brake as an operating brake for moving axes.

If the holding brake is repeatedly activated with the drive rotating or the allowed braking energy is exceeded, premature wear and tear may occur.

### 9.12.2 Holding Brakes - Notes Regarding Safety

Observe the safety requirements for the system planning and development.

**⚠ DANGER****Personal injury through hazardous movements caused by falling or descending axes!**

Secure vertical axes against falling or descending after disconnection:

- lock the vertical axes mechanically,
- provide an external braking / collecting / clamping device, or
- Ensure sufficient weight compensation of the axes.

The serially delivered holding brakes which are driven by the control device are **not** suited for personal safety!

Personal protection must be realized by superordinate fail-safe measures, such as e.g. the locking off of the danger zone by means of a protective fence or grill.



Beside the specified details and notes about holding brakes, heed the additional standards and directives when planning the system.

For European countries:

- **EN 954 and ISO 13849-1 and ISO 13849-2 Safety-related components of controls**
- **Information sheet no. 005 "Gravity-loaded axes (vertical axes)" published by: Fachausschuss Maschinenbau, Fertigungssysteme, Stahlbau**

For the USA:

- See National Electric Code (NEC), National Electrical Manufacturers Association (NEMA) as well as local building regulations.

The following is generally valid: Comply with all applicable national regulations!

The permanent magnetic brake is no safety brake. This means, a torque reduction by non-influenceable disturbance factors can occur (see EN 954 and ISO 13849-1 and ISO 13849-2 or the information leaflet No. 005 about "Gravity-loaded axes (vertical axes)").

Please pay particular attention to the following:

- Corrosion on friction surfaces, as well as dust, perspiration and sediments reduce the braking effect.
- Grease must not hit the friction surface.
- Overvoltage and too high temperatures can durably weaken the permanent magnets and thus the brake.

Engaging of the holding brake is no longer ensured, if the air gap between armature and pole is improperly increased due to deterioration. In this case, no braking occurs.

### 9.12.3 System Safety for Holding Brakes

#### Control of the Holding Brake during Operation (Recommendation)

Malfunctions that occur in the course of the operating period and that may change the design parameters or the operating conditions must be recognized and eliminated within an appropriated period of time. We recommend to check the function and the state of the holding brake in regular intervals.

## Operating Conditions and Application Notes

## 9.12.4 Layout of Holding Brakes

Holding brakes on motors are basically not designed for service braking. The effective braking torques are physically conditionally different in static and dynamic operation.

Normal operation and EMERGENCY STOP	event of faults
In <b>normal operation</b> , using the holding brake for clamping of a standstill axes, the "static holding torque" ( $M_4$ ), applies as indicated in the data sheets.  For <b>EMERGENCY STOP</b> to deactivate an axis ( $n < 10 \text{ min}^{-1}$ ), a "dynamic braking moment" acts ( $M_{\text{dyn}}$ ) - sliding friction.	For <b>fault conditions</b> to deactivate a moving axis ( $n \geq 10 \text{ min}^{-1}$ ), a "dynamic braking moment" acts ( $M_{\text{dyn}}$ ) - sliding friction.
<b><math>M_4 &gt; M_{\text{dyn}}</math></b> Therefore, note the following description of dynamic sizing.	

Fig.9-21: Dynamic Sizing

## Dynamic Sizing

The load torque must be smaller than the minimum dynamic moment  $M_{\text{dyn}}$  which the holding brake can provide. Otherwise the dynamic holding brake torque is not sufficient to stop the axes.

If a mass is to be decelerated in a defined time or in a defined route, the additional mass moment of inertia of the whole system must be taken into account.

## Project planning recommendation

To ensure construction safety, reduce the required holding torque to 60% of the static holding torque ( $M_4$ ) of the holding brake.

## 9.12.5 Holding Brake—Commissioning and Maintenance Instructions

In order to ensure proper functioning of the holding brake, it must be checked before the motors are commissioned. The test as well as the resurfacing may be carried out "mechanically by hand" or "automatically by means of the software function".

## Checking and resurfacing of holding brakes by hand

Measure the holding torque ( $M_4$ ) of the holding brake. If necessary, resurface the holding brake.

**Measuring the Holding Torque ( $M_4$ ) of the Holding Brake**

1. De-energize the motor and secure it against re-energization.
2. Measure the transferable holding torque of the holding brake with a torque wrench. For holding torque ( $M_4$ ) refer to the technical data.

If the holding torque ( $M_4$ ) is achieved, the motor is ready for assembly. If the holding torque ( $M_4$ ) is **not achieved**, the subsequent resurfacing-process can be used to reconstitute the holding torque.

**Resurfacing the Holding Brake**

1. At closed holding brake, turn the output shaft by hand, e.g. with the help of a torque wrench, by about 5 revolutions.
2. Measure the holding torque ( $M_4$ ).  
If the holding torque ( $M_4$ ) is achieved, the motor is ready for assembly.

## Operating Conditions and Application Notes

If the specified holding torque (M4) is not attained after several grinding-in processes, the holding brake is not operable. Please, contact the Rexroth Service.

### Checking and resurfacing of holding brakes by means of the software function

#### Checking the Holding Torque (M4) via P-0-0541, C2100 Command Holding system check

1. The efficiency of the holding brake and the opened state are checked by the control device by starting the routine "P-0-0541, C2100 Command Holding system check".

If the holding brake is operational, the drive is in an operational state after the routine was run through. If the braking torque is too low, the control device outputs a corresponding message.



The brake test can also be carried out cyclically in the framework of a preventive maintenance.

#### Restoring the Holding Torque (M4) by means of the Software Function

*The following possibilities are available:*

1. Realization of the resurfacing routine IndraDrive "Restoring the holding torque "(see"P-0-0544, C3900 Command Resurfacing of motor holding brake"). A repeated realization of the resurfacing routine is possible.

Upon the execution of the command C3900 it is not checked whether the resurfacing of the holding brake was successful. It is recommended to execute the command C2100 (Command Holding system check) once again.

2. Resurfacing routine by superior control. Here, special control programs adapted to the machine and system concepts are required. If necessary, please contact your Bosch Rexroth distribution partner and discuss the resurfacing routine parameters for your application.



For more detailed information about software functions refer to the functional description "Rexroth IndraDrive Firmware for Drive Control Devices MPx-xx, DOK-INDRV\*-MP\*-xxVRS\*\*-FKxx-EN-P."





# 10 Transport and Storage

## 10.1 Transport Instructions

Transport our products only in their original package. Also observe specific ambient factors to protect the products from transport damage.

Based on DIN EN 60721-3-2, the tables below specify classifications and limit values which are allowed for our products while they are transported by land, sea or air. Observe the detailed description of the classifications to take all of the factors which are specified in the particular class into account.

### Allowed classes of ambient conditions during transport acc. to DIN EN 60721-3-2

Classification type	Allowed class
Classification of climatic ambient conditions	2K2
Classification of biological ambient conditions	2B1
Classification of chemically active materials	2C2
Classification of mechanically active materials	2S2
Classification of mechanical ambient conditions	2M1

Fig. 10-1: Allowed classes of ambient conditions during transport

For the sake of clarity, a few essential environmental factors of the aforementioned classifications are presented below. Unless otherwise specified, the values given are the values of the particular class. However, Bosch Rexroth reserves the right to adjust these values at any time based on future experiences or changed ambient factors.

### Allowed transport conditions

Environmental factor	Symbol	Unit	Value
Temperature	$T_T$	°C	-20 ... +80 <sup>1)</sup>
Air humidity (relative air humidity, not combinable with quick temperature change)	$\varphi$	%	75 (at +30 °C)
Occurrence of salt mist			Not permitted <sup>1)</sup>

1) Differs from DIN EN 60721-3-2

Fig. 10-2: Allowed transport conditions



Before transport, empty the liquid coolant from the liquid-cooled motors to avoid frost damage.

### Transport by air

If motor components with permanent magnets are shipped by air, the DGR (Dangerous Goods Regulations) of the IATA (International Air Transport Association) for hazardous materials of class 9 which also include magnetized substances and objects must be observed. For example, these regulations are applicable for

- Secondary parts of synchronous linear motors
- Rotors of synchronous kit motors

## Transport and Storage

- Rotors of synchronous housing motors (if shipped as motor components, i.e., separated from the stator or motor housing in case service work is required)

For information on the maximum allowed magnetic strengths and methods of measuring such magnetic field strengths, please refer to the current IATA DGR (chapter 3.9.2.2).

## 10.2 Storage Instructions

### 10.2.1 Storage Conditions

Generally, Bosch Rexroth recommends to store all components until they are actually installed in the machine as follows:

- In their original package
- At a dry and dustfree location
- At room temperature
- Free from vibrations
- Protected against light or direct insolation

On delivery, protective sleeves and covers may be attached to our motors. They must remain on the motor for transport and storage. Do not remove these parts until shortly before assembly.

Based on DIN EN 60721-3-1, the tables below specify classifications and limit values which are allowed for our products while they are stored. Observe the detailed description of the classifications to take all of the factors which are specified in the particular classification into account.

#### Allowed classes of ambient conditions during storage acc. to DIN EN 60721-3-1

Classification type	Class
Classification of climatic ambient conditions	1K2
Classification of biological ambient conditions	1B1
Classification of chemically active materials	1C2
Classification of mechanically active materials	1S1
Classification of mechanical ambient conditions	1M2

Fig. 10-3: Allowed classes of ambient conditions during storage

For the sake of clarity, a few essential environmental factors of the aforementioned classifications are presented below. Unless otherwise specified, the values given are the values of the particular class. However, Bosch Rexroth reserves the right to adjust these values at any time based on future experiences or changed ambient factors.

#### Allowed classes of ambient conditions during storage acc. to DIN EN 60721-3-1

Environmental factor	Symbol	Unit	Value
Air temperature	$T_L$	°C	-20 ... +60 <sup>1)</sup>
Relative air humidity	$\varphi$	%	5 ... 95
Absolute air humidity	$\rho_w$	g/m <sup>3</sup>	1 ... 29
Condensation	--	--	Not allowed
Ice formation/freezing	--	--	Not allowed
Direct solar radiation	--	--	Not allowed <sup>1)</sup>
Occurrence of salt mist	--	--	Not allowed <sup>1)</sup>

1) Differs from DIN EN 60721-3-1

Fig. 10-4: Allowed storage conditions

## Transport and Storage



Before re-storage, empty the liquid coolant from the liquid-cooled motors to avoid frost damage.

## 10.2.2 Storage Times

Additional measures must be taken on commissioning to preserve proper functioning – irrespective of the storage time which may be longer than the warranty period of our products. However, this does not involve any additional warranty claims.

## Motors

Storage time	Measures for commissioning
< 1 year	Resurface the holding brake
1 ... 5 years	<ol style="list-style-type: none"> <li>1. Check the electric contacts to verify that they are free from corrosion</li> <li>2. Let the motor run in without load for one hour at 800 ... 1000 rpm</li> <li>3. Resurface the holding brake</li> </ol>
> 5 years	<ol style="list-style-type: none"> <li>1. Exchange bearings</li> <li>2. Exchange encoders</li> <li>3. Resurface the holding brake</li> <li>4. Check the electric contacts to verify that they are free from corrosion</li> </ol>

Fig.10-5: Measures before commissioning motors that have been stored over a prolonged period of time

## Cables and connectors

Storage time	Measures before commissioning
< 1 year	None
1 ... 5 years	⇒ Check the electric contacts to verify that they are free from corrosion
> 5 years	⇒ Should the cable or the cable jacket have porous parts, change them, otherwise check the electric contacts if they are free of corrosion.

Fig.10-6: Measure before commissioning cables and connectors that have been stored over a prolonged period of time

# 11 Delivery Status, Identification, Handling

## 11.1 State of Delivery

### 11.1.1 General Information

On delivery, the MKE motors are packed in cardboard boxes or wooden crates. Packing units on pallets are secured by means of retaining straps.

---

**⚠ CAUTION**

**Injuries due to uncontrolled movement of the retaining straps when cutting!**

Maintain a sufficient distance and carefully cut the bandages.

---

Motor shaft and plug connections are provided with protective sleeves at the factory. Remove these protective sleeves only immediately before starting assembly.

### 11.1.2 Inspection at the Factory

All MKE motors undergo the following tests, among others, at the factory:

- |                        |   |
|------------------------|---|
| <b>Electrical test</b> | <ul style="list-style-type: none"><li>• High-voltage test according to DIN EN 60034-1 / 02.99</li><li>• Insulation resistance test according to EN 60204-1/1.92, section 20.3.</li><li>• Grounding conductor test according to EN 60204-1/1.92, section 20.3.</li><li>• Test of winding resistance</li></ul>  |
| <b>Mechanical test</b> | <ul style="list-style-type: none"><li>• Concentricity and position tolerances of shaft end and fastening flange according to DIN 42955/12.81</li><li>• Axial eccentricity of the flange face to the shaft according to DIN 42955/12.81.</li><li>• Coaxiality of the centering shoulder to the shaft according to DIN 42955/12.81.</li><li>• Test of brake holding torque (option)</li></ul> |

### 11.1.3 Test Realized by the Customer

Since all MKE motors undergo a standardized inspection procedure, high-voltage tests on the customer side are not required. Motors and components could be damaged if they undergo several high-voltage inspections.

---

**NOTICE**

**Destruction of motor components due to improperly executed high-voltage inspection! Invalidation of warranty!**

Avoid repeated inspections.

Please observe the target values of the EN 60034-1.

---

Delivery Status, Identification, Handling

## 11.2 Identification

### 11.2.1 Scope of Delivery

The total scope of a delivery is specified on the delivery or consignment note. However, the contents of a delivery can be distributed over several packages. Each individual package can be identified using the shipment label attached. Check if the delivered goods comply with the order and all freight papers, after receipt of delivery.

Complain any deviations immediately at your local Rexroth sales partner.

Complain visible transport damage directly at the carrier.

### 11.2.2 Rating Plate

Each motor has an individual type plate showing the device designation and providing technical information. A second type plate is delivered with the motor, additionally.

Use the second attached type plate and bring it clearly-visible on the machine, if the origin type plate on the motor is covered by a machine contour. This type plate is enclosed either to the motor or re-detachable affixed on the original type plate.

The type plate is provided for

- Identification of the motor
- Procurement of spare parts in case of a fault
- Service information.



The type designation of the motor is also filed in the encoder data memory.

---

Because of different national regulations, different type plates are used for motors according to EN and UL-standards. The differences are shown in the following picture.

Delivery Status, Identification, Handling

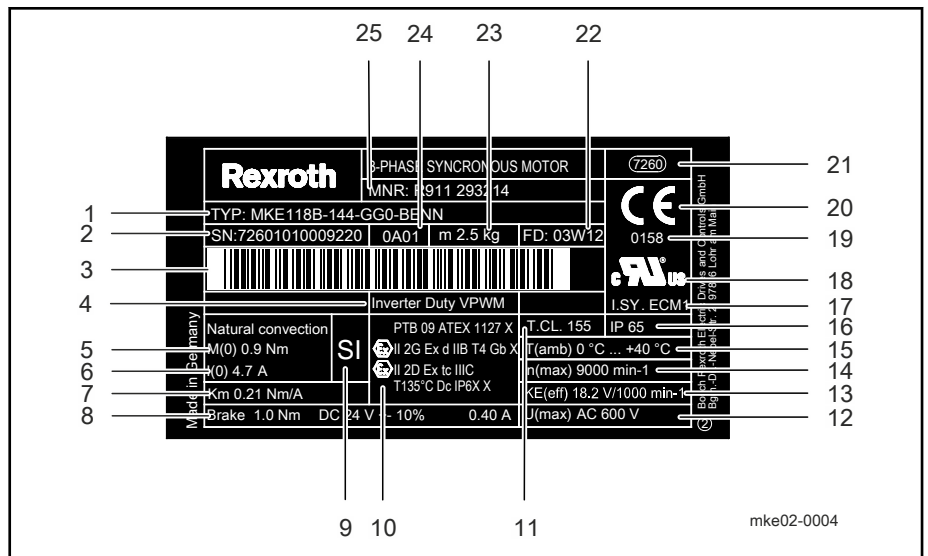

- 1 Motor type (ordering designation according to the type code)
- 2 Serial number
- 3 Barcode
- 4 Inverter Duty VPWM
- 5 Continuous torque at standstill 60K
- 6 Continuous current at standstill 60K
- 7 Torque constant 20°C
- 8 Data about holding brakes, optional (holding brake, voltage, current)
- 9 Designation motor prepared for safety technique
- 10 Explosion protection designation (test number, designation flammable gas; designation flammable dust)
- 11 Temperature class
- 12 Voltage class
- 13 Voltage constant
- 14 Maximum velocity
- 15 Environmental temperature (in operation)
- 16 Degree of protection housing
- 17 Designation isolation system (UL)
- 18 Designation cURus
- 19 Code number of the test authority
- 20 CE conformity
- 21 Factory number
- 22 Production date
- 23 Netto weight
- 24 Revision state
- 25 Part number

Fig. 11-1: Example of MKE type plate in EU-standard

## Delivery Status, Identification, Handling

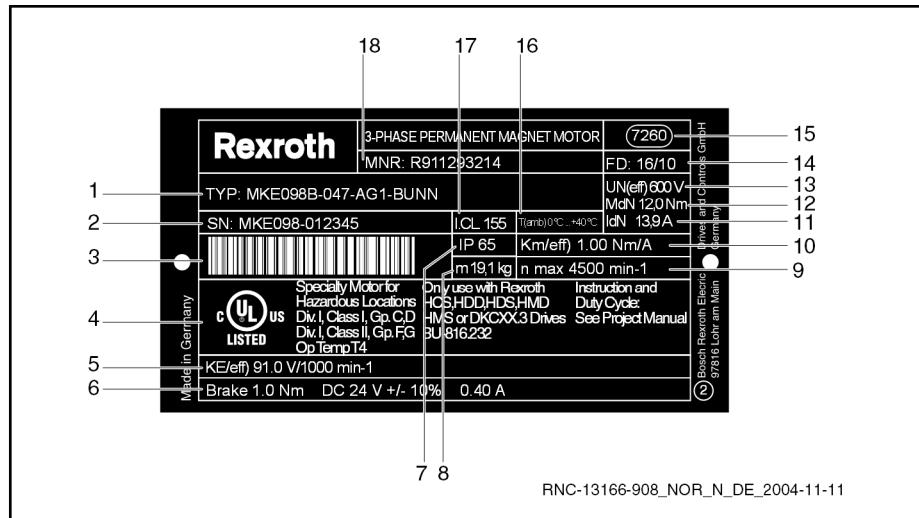

- 1 Motor type (ordering designation according to the type code)
- 2 Serial number
- 3 Barcode
- 4 Explosion protection UL designation
- 5 Voltage constant
- 6 Data about holding brakes, optional (holding brake, voltage, current)
- 7 Degree of protection housing
- 8 Netto weight
- 9 Maximum velocity
- 10 Torque constant
- 11 Continuous current at standstill
- 12 Continuous torque at standstill
- 13 Rated voltage
- 14 Production date
- 15 Factory number
- 16 Ambient temperature range
- 17 Temperature class
- 18 Part number

Fig.11-2: Example of MKE type plate in UL-standard



## 11.3 Handling

**⚠ CAUTION**

**Injuries due to improper handling during transport of motors!**

Do only use suitable lifting devices (e.g. lifting sling belts, eyebolts, chain suspension ...).

Use protective equipment and personal protective clothing (gloves, safety shoes, ...).

Never walk under hanging loads.

**NOTICE**

**Damage of property and invalidation of the warranty due to incorrect storage!**

Store the motors horizontally in their original packaging in a dust-free, dry, vibration-free and sun-protected environment.

Also observe the notes regarding storage and transport on the packaging.

**Handling**

On delivery, the MKE motors have protective caps and covers on the output shaft and on the flange sockets. During transport and storage, the protective sleeves must remain on the motor.

- Remove these protective sleeves only immediately before starting assembly.
- Also use the protective sleeves if you return the goods.
- Avoid any damage to the motor flange and drive shaft.

**NOTICE**

**Motor damage due to beats onto the motor shaft**

Do never beat onto the shaft end and do not exceed the allowed axial and radial forces of the motor.

**Transport**

Please, observe the following points during transport:

- Use suitable means of transport and consider the weight of the components (you can find the weight information on the data sheets or on the type plate of the motor).
- Provide appropriate shock absorbers, if strong vibrations may occur during transport.
- Transport the motors only in the horizontal position.
- Use cranes with lifting sling belts to lift the motors.

## Delivery Status, Identification, Handling

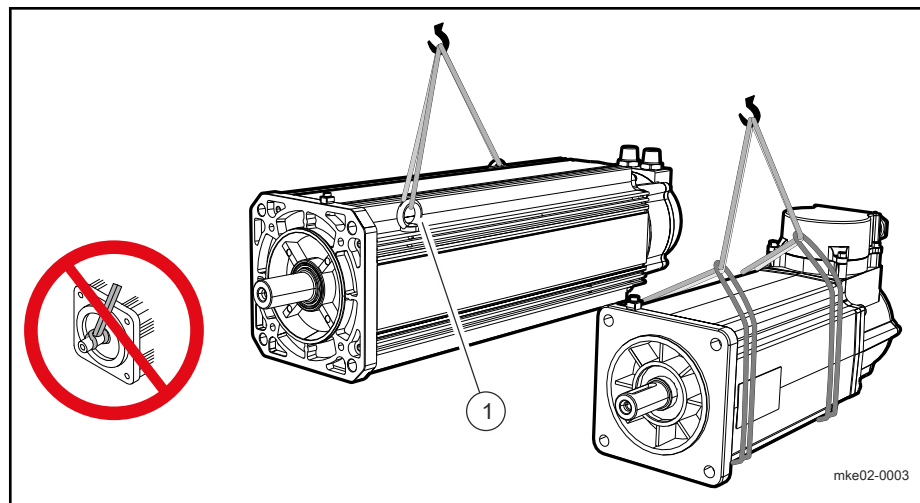

1 Eye bolts (check firm seating before use)

*Fig.11-3: Lifting and transporting motors by means of lifting sling belts*

## 12 Installation

### 12.1 Safety

---

**⚠ DANGER****Death by electrocution possible due to live parts with more than 50V!**

Open connectors of the motor only when the system has been de-energized.

Heed the safety instructions according to DIN EN 50110-1:

1. Disconnect.
2. Protect the system or plant against restart.
3. Determine de-energization.
4. Ground and short-out.
5. Cover or shield any adjacent live parts.

Before starting to work, check with an appropriate measuring device (e.g. an multimeter) whether parts of the system are still under residual voltage (e.g. caused by capacitors, etc.). Wait for their discharging time.

---

**⚠ CAUTION****Injuries due to improper handling during transport of motors!**

Do only use suitable lifting devices (e.g. lifting sling belts, eyebolts, chain suspension ...).

Use protective equipment and personal protective clothing (gloves, safety shoes, ...).

Never walk under hanging loads.

---

Carry out all working steps with particular care This minimizes the risk of accidents and damage.

## Installation

## 12.2 Skilled Personnel

Any works on the system and on the drives or in their vicinity must only be carried out by appropriately trained technical personnel.

Please make sure that all persons carrying out

- installation works
- maintenance, or
- operating activities

on the system are adequately familiar with the contents of this documentation as well as with all warnings and precautionary measures contained therein.



Qualified technical personnel are those persons who have been trained, instructed or are authorized to activate and deactivate, ground and mark electric circuits and equipment according to the technical safety regulations. Qualified technical personnel must possess appropriate safety equipment and have been trained in first aid.

## 12.3 Mechanical Mounting – Motor Assembly

### 12.3.1 Flange Assembly

To attach the motors properly and safely to the machine, Rexroth recommends the following screws and washers for attachment.



The screwed connections must be able to take up both the force due to the weight of the motor and the forces acting during operation.

In the standard case, use cylinder screws DIN 912 - M... x ... - 8.8 and corresponding shimmings according to DIN EN 28738. Some motors do not need any shimmings. See table.



If the screws and washers used do not comply with this recommendation, the stability class of the screws and the hardness class must be equivalent in order to transmit the required tightening torques (see Fig. 12-1).

MKE motors are designed for flange assembly (B05). Details on the mounting holes are given in the corresponding dimension sheet. In general, the following assignment is applicable for attaching the motors:

Motor	B05 (flange assembly)			
	Hole	Screw (8.8)		Washer DIN EN 28738
	Ø [mm]	Type <sup>1)</sup>	M <sub>GA</sub> [Nm]	Ø [mm]
MKE037	4.5	M4×20	3.1	not necessary
MKE047	6.6	M6×20	10.4	not necessary
MKE098	11.0	M10×30	51	12
MKE118	14.0	M12×40	87	14

M<sub>GA</sub> Tightening torque in Newton meters

1) The indicated screw lengths apply for screwing into steel.

Fig. 12-1: Fastening accessory for flange mounting

### 12.3.2 Preparation

Prepare the motor assembly as follows:

1. Procure tools, supplies, measuring and test equipment.
2. Check all components for visible damage. Damaged components may not be mounted.
3. Ensure that dimensions and tolerances on the system side are suitable for motor attachment (for details, see the dimension sheet).
4. Inspect all components, mounting surfaces and threads to ensure they are clean.
5. Make sure that the assembly can be carried out in a dry and dust-free environment.
6. Make sure that the holder for the motor flange is deburred.

## Installation

7. Remove the protective sleeve of the motor drive shaft and keep it for further use.
8. Only for motors with holding brake:  
Check whether the motor holding brake reaches the holding torque specified in the data sheet. Should the brake fail to reach the torque specified, first resurface the holding brake as described under Chapter 9.12.5.

### 12.3.3 Assembly

Please note the following points when mounting the motors:

1. Avoid pinching or jamming the centering collar on the motor side.
2. Avoid damage to the insertion fitting on the system side.
3. Before you proceed, check the fit and precision of the connection.

After having assembled the motor mechanically, prepare it for electrical connection.

## 12.4 Electrical Connection

### 12.4.1 Safety Instructions

It is recommended that you use ready-made Rexroth connection cables. These cables provide a number of advantages, such as UL/CSA authorization, extreme load capability and resistance as well as a design suitable for EMC.

#### DANGER

**Danger of life due to electrical power! Handling within the area of live parts is extremely dangerous.**

- Any work required on the electric system must only be carried by skilled electricians. It is absolutely necessary to use power tools.
- Before working
  1. Disconnect.
  2. Protect the system or plant against restart.
  3. Determine de-energization.
  4. Ground and short-out.
  5. Cover or shield any adjacent live parts.
- Before starting to work, check with an appropriate measuring device whether parts of the system are still under residual voltage (e.g. caused by capacitors, etc.). If yes, wait until these parts have discharged.

### 12.4.2 Electric Connection MKE037, MKE047, MKE098 Housing Design "E"

The accessory kit **SUP-M02-MKE** is necessary to connect the motor. The accessory kit is enclosed to the motors at delivery.

#### Content accessory kit SUP-M02-MKE

Number	Designation
1	Connector housing X3 (encoder 10 pole)
11	Contact encoder connector
1	Clamp terminal X2 (MotTemp / Br)
2	Terminal end
1	Package insert SUP-M02-MKE
4	Pan head screw M5 x 14 DIN 912 (coated)
1	Plug-in interlock for X3

## Installation

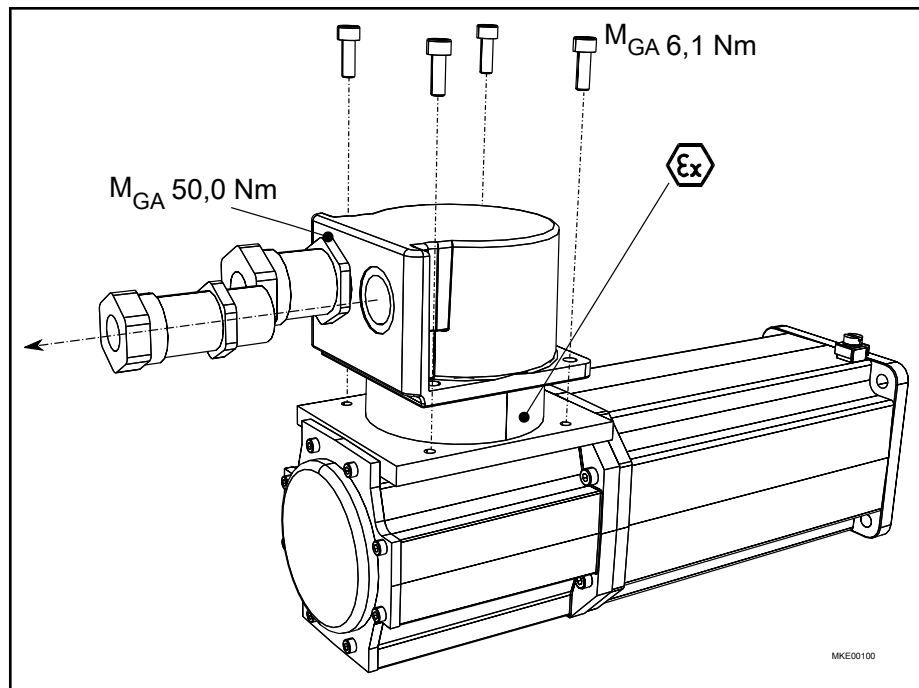

Fig. 12-2: Electric Connection MKE037, MKE047, MKE098 Housing Design "E"

**⚠ WARNING**

**High electrical voltage! Danger to life, danger of injury due to electric shock.**

All work done on a disconnected and secured against re-start locked low voltage machine is to be carried out by skilled personnel. This is also valid for auxiliary currents (like temperature sensors).

All work must be carried out at motor standstill. Motors with permanent magnet field strength create at rotating rotor a voltage > 60V on the motor connections.

*Note for Assembly*

- Flameproof joints must be opened and jointed during assembly operations. Avoid damage on the flameproof joints. Do not remove existing assembly grease. Let the o-rings in their factory-adjusted position. Work in a clean environment.
- When assembly damage on the flameproof joints occurred, the motor must be repaired with original spareparts by the Rexroth service.
- Lid screws are coated. By screwing in and out the screws, the coating wears. Use the enclosed screws at assembly. Secure the lid screws with Loctite 243® at re-assembly.

**Connection ready-made cables**

1. Remove Ex-screw connection for encoder cables, use screw connection on the ready-made cable. Tighten the screw connection with 50 Nm in the lid housing.
2. Insert the power cable into the lid housing and tighten the Ex-screw connection.



## Installation

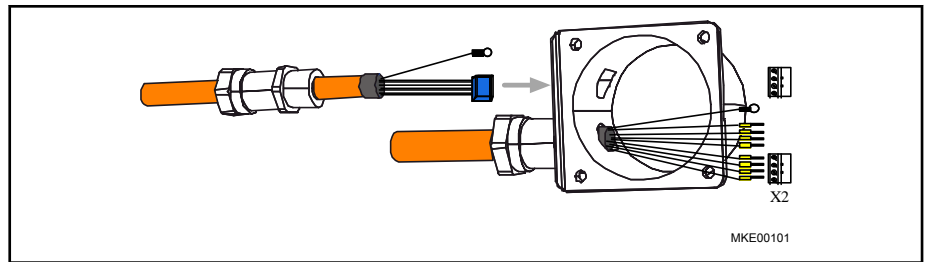

Fig. 12-3: Insert the cables

3. Connect the enclosed clamp terminal X2 on the wires for holding brake and temperature sensor acc. to the interconnection diagram (tightening torque of the clamping screws 0.5 Nm).
4. Do the shield connection of power and encoder cable. Connect the ring terminal on clamping sites within the lid housing (tightening torque 1.3 Nm)
5. Connect the power wires acc. to the interconnection diagram on X1 (tightening torque of clamping screws 0.9 Nm)
6. Plug in the clamp terminal X2 onto the printed circuit board within the motor.  
Plug in the clamp terminal X3 onto the printed circuit board within the motor.

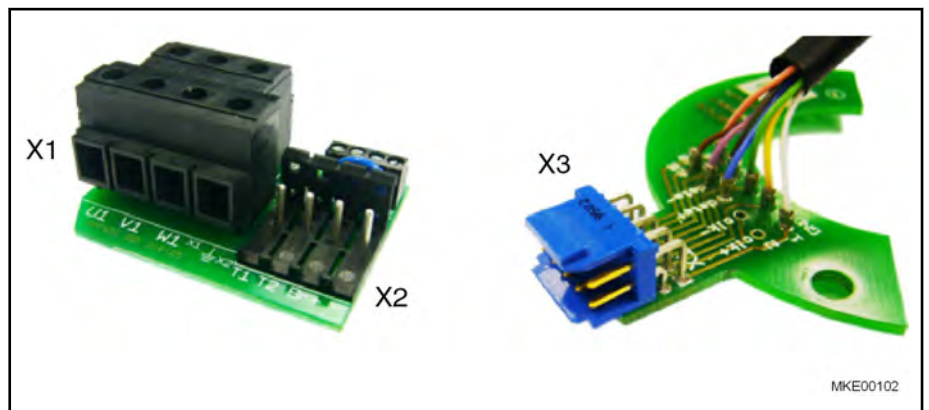

Fig. 12-4: MKE connection points

If you do not use ready-made cables:

- you have the possibility to order a hand crimping tool to handle the clamp terminal X3 at Bosch Rexroth. **Order number: R911262293.**
- Assemble the pins within connector housing X3 as described in the figure.

## Installation

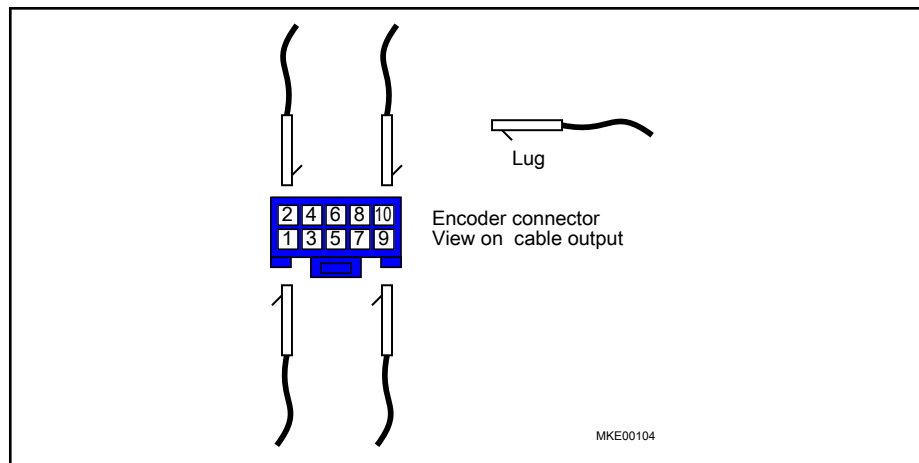

Fig. 12-5: Assembly encoder connector

- Assemble the plug-in interlock on the connector housing X3.

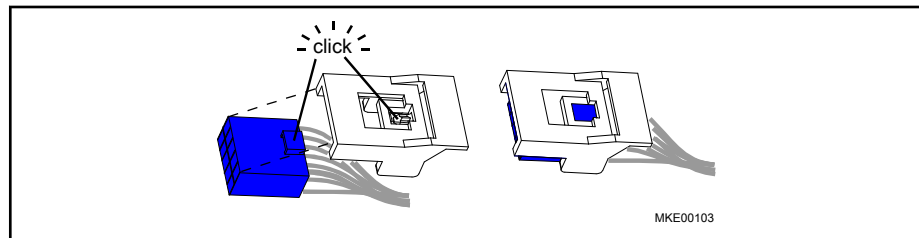

Fig. 12-6: Plug-in interlock

### 12.4.3 Electric Connection MKE118 Housing Design "E"

The accessory kit **SUP-M01-MKE118** is necessary to connect the motor. The accessory kit is enclosed to the motors at delivery.

#### Content accessory kit SUP-M02-MKE

Number	Designation
1	Connector housing X3 (encoder 10 pole)
11	Contact encoder connector
1	Clamp terminal X2 (MotTemp / Br)
2	Terminal end
1	Package insert SUP-M01-MKE118
4	Pan head screw M6 x 25 ISO 4762 (coated)
1	Plug-in interlock for X3
12	Grommets

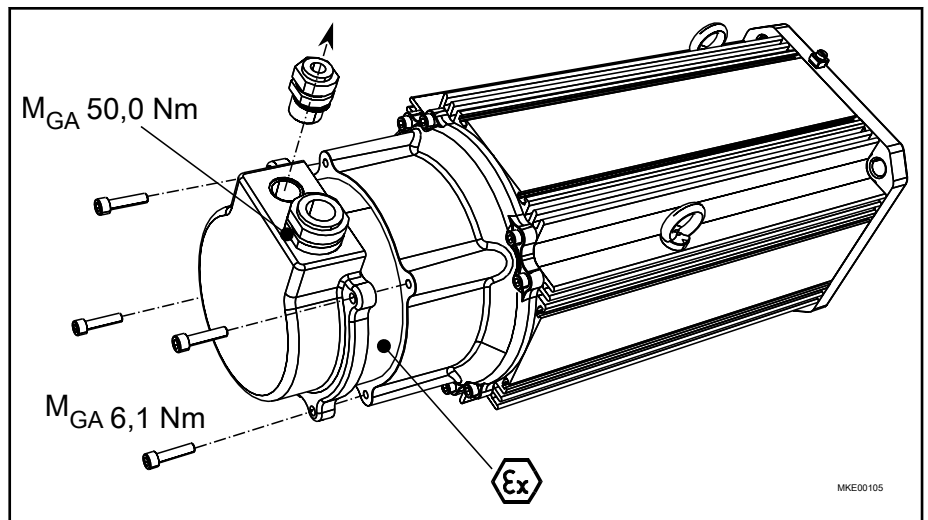

Fig. 12-7: Electric Connection MKE118 Housing Design "E"

**⚠ WARNING**

**High electrical voltage! Danger to life, danger of injury due to electric shock.**

All work done on a disconnected and secured against re-start locked low voltage machine is to be carried out by skilled personnel. This is also valid for auxiliary currents (like temperature sensors).

All work must be carried out at motor standstill. Motors with permanent magnet field strength create at rotating rotor a voltage > 60V on the motor connections.

*Note for Assembly*

- Flameproof joints must be opened and jointed during assembly operations. Avoid damage on the flameproof joints. Do not remove existing assembly grease. Let the o-rings in their factory-adjusted position. Work in a clean environment.
- When assembly damage on the flameproof joints occurred, the motor must be repaired with original spareparts by the Rexroth service.
- Lid screws are coated. By screwing in and out the screws, the coating wears. Use the enclosed screws at assembly. Secure the lid screws with Loctite 243® at re-assembly.

**Cable glands** MKE118/EU motors of Rexroth are to be connected with especially to the cable outer diameter matched Ex-threads.

The cable entries must be fastened into the electrical apparatus in such a way that they are secured against twisting and self-loosening.

Grommets **have to be used** at mounting, which are adjusted with the cable outer diameter in which the threads must be applied.

## Installation

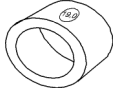
Screwed connection 	Available grommets with nominal diameter <sup>1)</sup>						
LE20/9 (Encoder)	8.5	9.0	9.5	-	-	-	-
LE26/15 (Power 2.5 mm <sup>2</sup> )	13.5	14.0	14.5	15.0	15.5	16.0	16.5
LE26/19 (Power 6.0 mm <sup>2</sup> )	17.5	18.0	18.5	19.0	19.5	-	-

<sup>1)</sup> Tolerance -0.5 mm

Fig. 12-8: Grommets for Ex-fittings

### DANGER

**Danger of explosion, danger to life, heavy injury and material damage**

Only according to the rules mounted cable fittings hinder the penetration of hazardous gases/dusts.

Make sure that only grommets are used, which are adjusted to the cable diameter.



The explosion protection for the cable entries can only be guaranteed, when they are in their original condition. The explosion protection can no longer be guaranteed, if:

- the isolator is damaged, broken or flaking.
- The winding of the screw-grommet is damaged.
- The cleavage face of the assembling bolt was changed, processed or damaged.

Maintenance and repair of MKE motors have to be done by Rexroth service.

The following steps are necessary:

1. Collect the outer diameter of the cable on the clamping of the cable fitting.

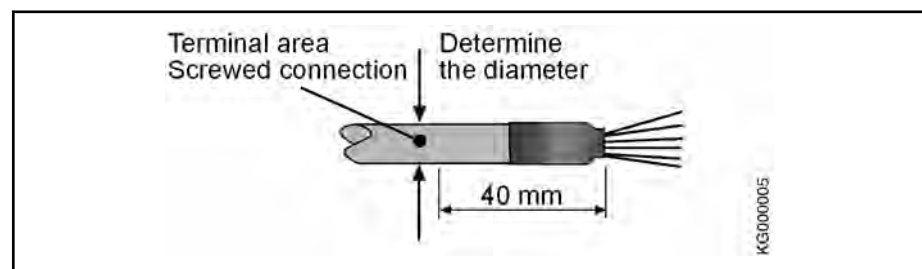

Fig. 12-9: Define the cable diameter

2. Select the necessary grommet and mount it on the cable fitting.
3. Tighten the cable fitting as far as it will go.

The cable fittings are mounted according to the Ex-regulations.

### Mount and connect ready-made cables

Ready-made cables are mounted according to Fig. 12-10.

## Installation

When using ready-made encoder cables, remove the fitting, which is mounted on the motor and use the fitting, which is mounted on the cable.

It is not necessary to define the cable outer diameter, now.

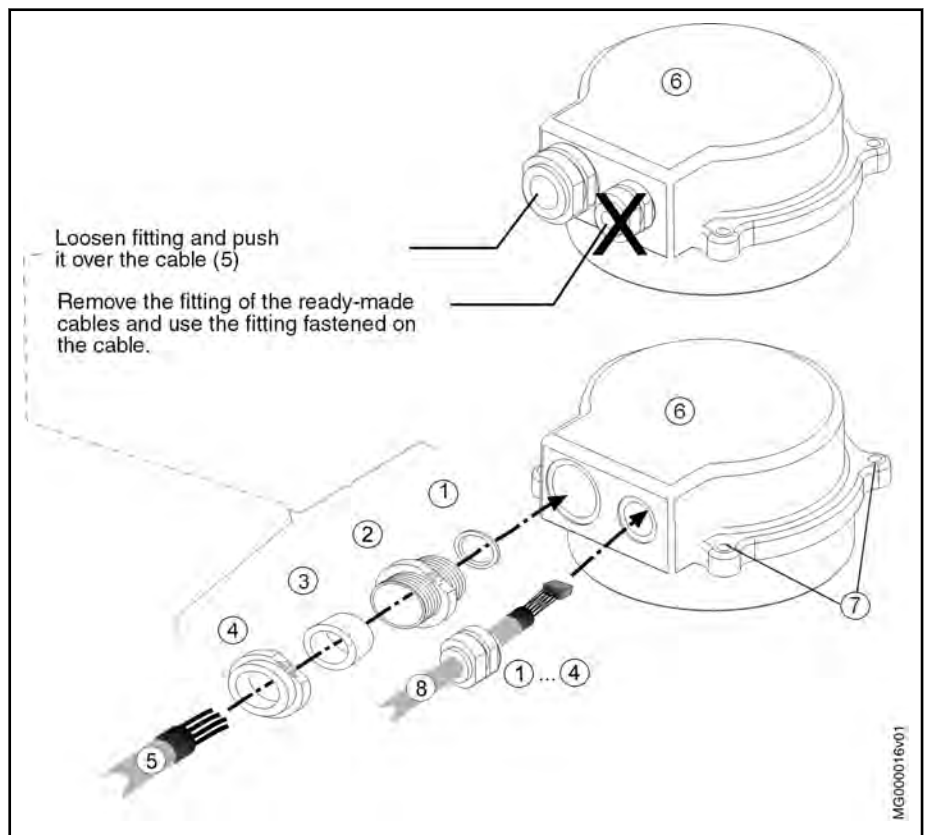

- ① Sealing
- ② Screwed connection
- ③ Use grommets according to the cable diameter.
- ④ Union nut
- ⑤ Ready-made power cable
- ⑥ Terminal box lid
- ⑦ Cover screws
- ⑧ Ready-made encoder cable

Fig. 12-10: Mounting the EExd-fitting and MKE118 cable



Loosen and re-tighten the cable fittings is not permitted. In this cases, a "new grommet" is to be used.

1. Connect the shield.  
Connect the ring terminal of the power and encoder cable on the X5 within the terminal box lid  
(Tightening torque 1.3 Nm 10%)
2. Connect the power cable.  
Lay the wires according to the interconnection plan onto the terminal block X1 and X2.
3. Assemble the plug-in interlock on encoder connector X3.

## Installation

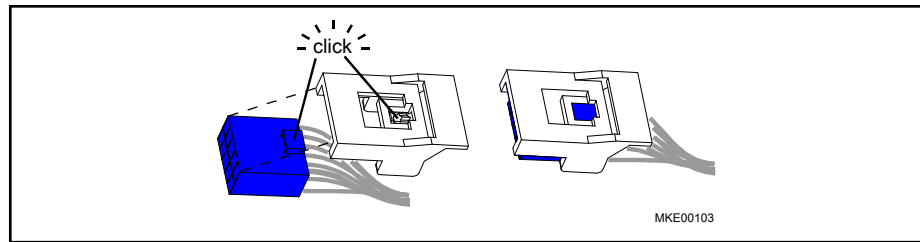

Fig. 12-11: Plug-in interlock

4. Connect the encoder cable.
5. Mount the terminal box lid.

Set the terminal box lid (9) on the motor. Make sure that no wire can be crushed or damaged.

6. Tighten the terminal box lid ⑥ with the added TFL-coated lid screws ⑦ with 6.1 Nm.



When changing the lid screws ⑦ do only use hexagon socket-head bolt acc. to DIN EN ISO 4762 with strength 8.8 (or higher).



When mounting the terminal box lid, secure the lid screws ⑦ with Loctite 243 ⑧.

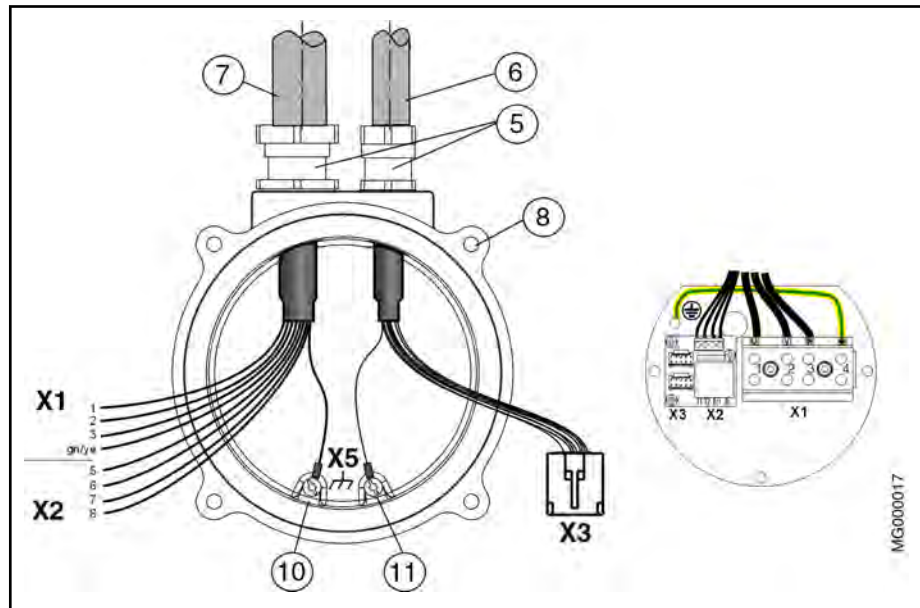

- ⑤ EExd-Cable screwing
- ⑥ Encoder Cables
- ⑦ Power cables
- ⑧ Lid screw tighten torque 6.3 Nm
- ⑩, ⑪ Shield connection screw tighten torque 1.3 Nm
- X1 Power connection
- X2 Brake, temperature
- X3 Encoder connector
- X5 Shield connection

Fig. 12-12: Insert power and encoder cable MKE118

### 12.4.4 Electric Connection Motor Types MKE037 ... 098 Housing Design "U"

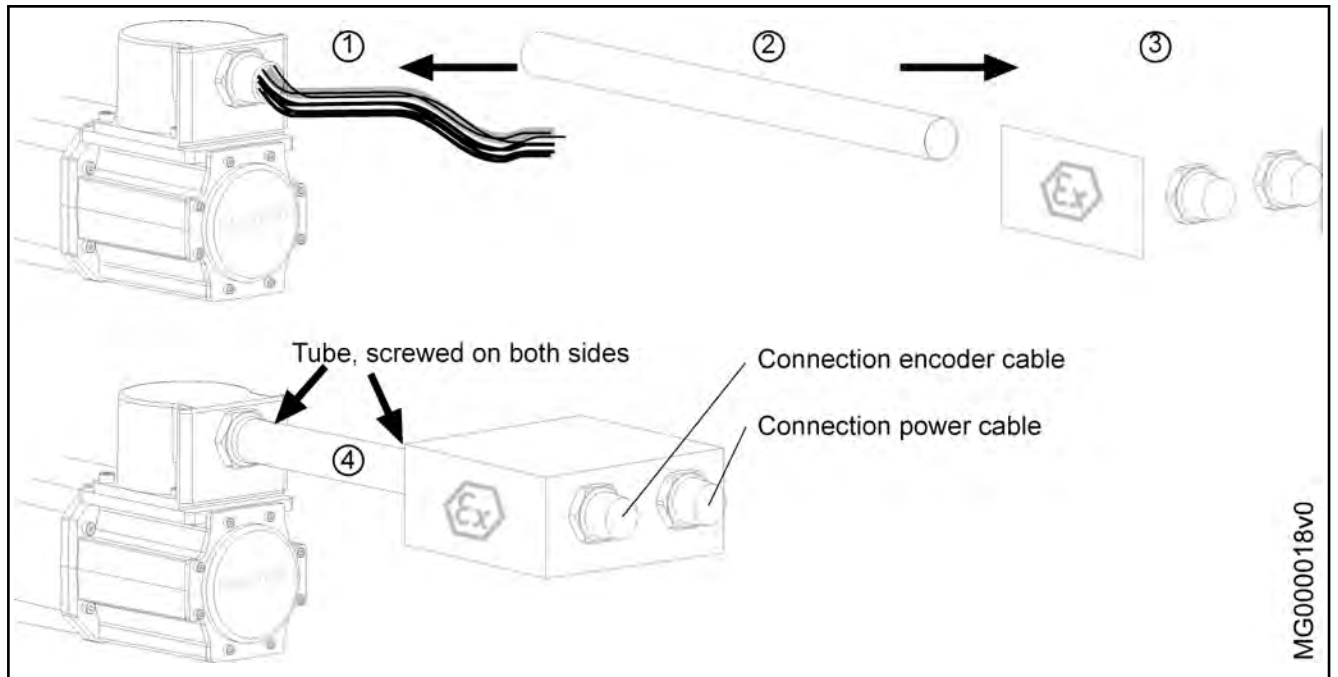

- (1) MKE with connection cable (single conductor)
- (2) Steel pipe NPT 3/4 inch (not in the scope of delivery)
- (3) Ex-terminal box (not included in scope of delivery)
- (4) Lead the connection cable into the steel tube

Fig. 12-13: Electric connection MKE037, -047, -098 UL



The machine manufacturer is responsible for observing the respectively valid standards and regulations.

Apply the shield in the Ex-terminal box as described in the documentation DOK-GENRL\*-EMV\*\*\*\*\*-PRxx-DE-P.

Wire up the single wires according to the mechanical assembly within the Ex-terminal box according to the interconnection diagram (Fig. 8-5).

## Installation

## 12.4.5 Electric Connection MKE118 Housing Design "U"

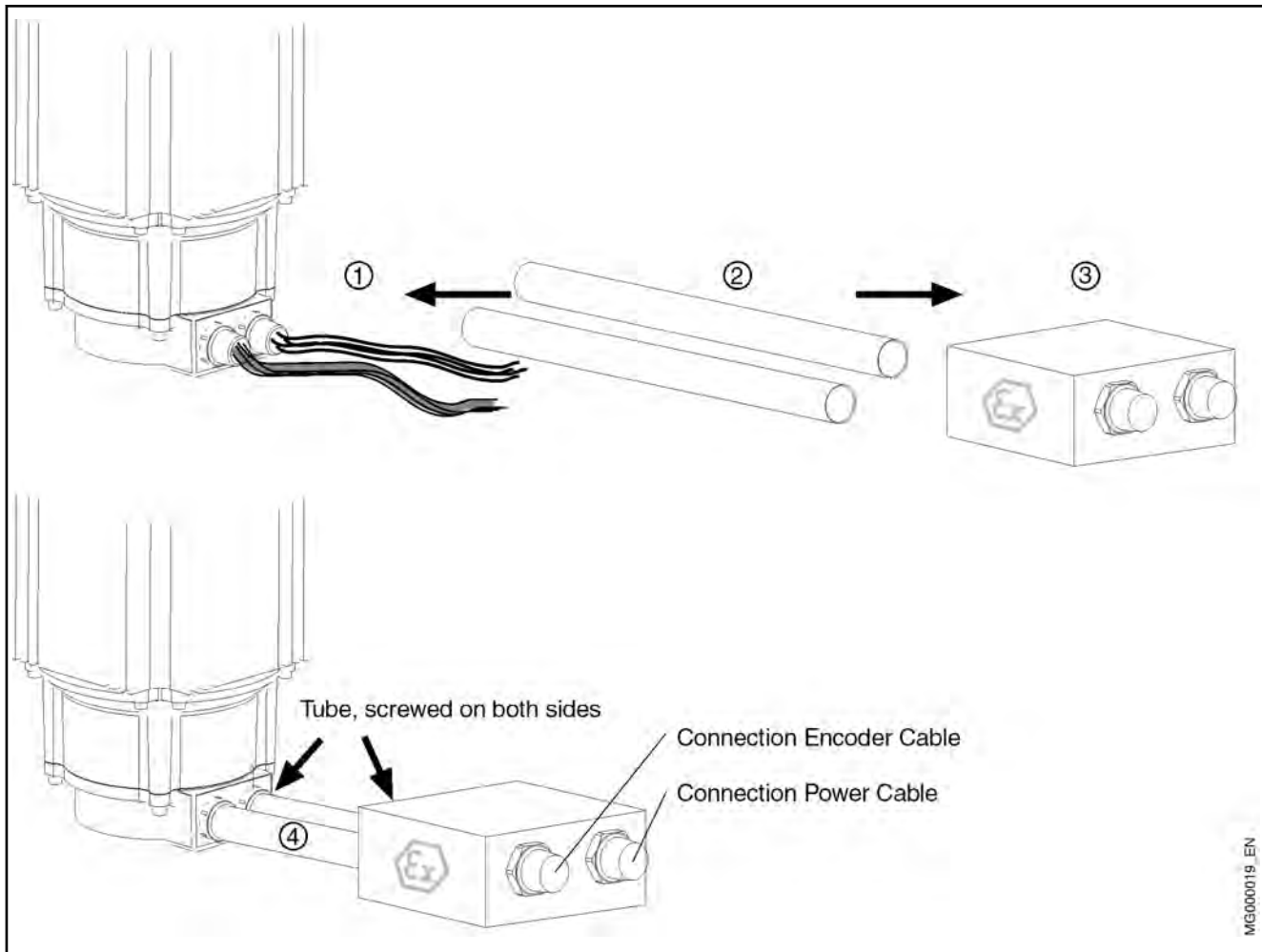

- (1) MKE with connection cable (single conductor)
- (2) Steel pipe NPT 3/4 inch (not in the scope of delivery)
- (3) Ex-terminal box (not included in scope of delivery)
- (4) Lead the connection cable into the steel tube

Fig. 12-14: Electric connection MKE118 UL



The machine manufacturer is responsible for observing the respectively valid standards and regulations.

Apply the shield in the Ex-terminal box as described in the documentation DOK-GENRL\*-EMV\*\*\*\*\*-PRxx-DE-P.

Wire up the single wires according to the mechanical assembly within the Ex-terminal box according to the interconnection diagram (Fig. 8-5).



# 13 Commissioning, Operation and Maintenance

## 13.1 Commissioning

Commissioning in ATEX atmospheres is prohibited until it has been ascertained that the overall system corresponds to the demands and certification conditions for ATEX protection.

The motors must only be operated with Rexroth drive control devices. Control devices from other manufacturers are not permitted.

### CAUTION

Damage to property due to errors in the controls of motors and moving elements! Unclear operating states and product data!

Do not perform a commissioning, if ...

- the connections, operating states or product data are unclear or faulty.
- the safety equipment and monitoring of the system is damaged or not in operation.

Never use any damaged products.

Contact Rexroth for missing information or support during commissioning.

#### Preparation

1. Keep the documentation of all products you are using ready.
2. Check the products for damage.
3. Check all mechanical and electrical connections (incl. the potential equalization line!).
4. Log all measures taken in the commissioning log.
5. Activate the safety and monitoring equipment of the system.

#### Bulk head connector

When all requirements are met, proceed as follows:

1. Carry out the commissioning of the drive system according to the instructions of the corresponding product documentation. You can find the respective information in the functional description of the drive control devices.
2. Log all measures taken in the commissioning report.

The commissioning of drive control devices and the control unit may require additional steps. The inspection of the functioning and performance of the systems is not object of these operating instructions; instead, it is carried out within the framework of the commissioning of the machine as a whole. Observe the instructions and regulations given by the machine manufacturer.

Commissioning, Operation and Maintenance

## 13.2 Operation

Ensure that the ambient conditions described in Chapter [chapter 9.2 "Installation Altitude and Ambient Temperature"](#) on page 79 are kept during operation.

## 13.3 Maintenance / Dismantling / Repair

### 13.3.1 Dismantling

---

**⚠ DANGER**

**Danger of explosion, fire or danger to life due to sparking when working in hazardous areas!**

Do only work on the motor in **non** explosible atmosphere and in de-energized state.

Heed the safety instructions according to DIN EN 50110-1:

1. Disconnect.
2. Protect the system or plant against restart.
3. Determine de-energization.
4. Ground and short-out.
5. Cover or shield any adjacent live parts.

Before starting to work, check with an appropriate measuring device (e.g. an multimeter) whether parts of the system are still under residual voltage (e.g. caused by capacitors, etc.). Wait for their discharging time.

---

---

**⚠ WARNING**

**Damage to persons and property at installation work!**

- Do not work on unsecured and operating machines.
  - Before working, secure the machine against accidental movements and against unauthorized operation.
  - Before dismantling, secure the motor and power supply against falling or movements before disconnecting the mechanical connections.
- 

---

**⚠ CAUTION**

**Combustions via hot surface with temperatures over 100 °C**

Let the motor cool down, before maintenance. The thermal time constant stated in the technical data is a measure for the cooling time. A cooling time up to 140 minutes can be necessary!

Use safety gloves.

Do not work on hot surfaces.

---

**In case of malfunctions, maintenance works or dismantling of the motors, proceed as follows:**

1. Use the control commands to bring the drive to a controlled standstill.
2. Switch off the power and control voltage of the drive device.
3. Switch off the main switch of the machine.
4. Secure the machine against accidental movements and against unauthorized operation.
5. Wait for the cooldown times of the motor and the discharge time of the electrical systems to elapse.
6. Disconnect all electrical connections.

## Commissioning, Operation and Maintenance

7. Before dismantling, secure the motor and power supply against falling or movement before disconnecting the mechanical connections.
8. Dismantle the motor from the machine.
9. Log all measures taken in the commissioning report.

### 13.3.2 Maintenance / Repair

Increase availability with regular preventive maintenance measures. Notice the information in the maintenance schedule of the machine manufacturer and the following details regarding maintenance measures and intervals for the motor.

**⚠ DANGER**

**Danger of explosion, fire or danger to life due to sparking when working in hazardous areas!**

Do only work on the motor in **non** explosible atmosphere and in de-energized state.

Heed the safety instructions according to DIN EN 50110-1:

1. Disconnect.
2. Protect the system or plant against restart.
3. Determine de-energization.
4. Ground and short-out.
5. Cover or shield any adjacent live parts.

Before starting to work, check with an appropriate measuring device (e.g. an multimeter) whether parts of the system are still under residual voltage (e.g. caused by capacitors, etc.). Wait for their discharging time.

#### Maintenance

Measure	Interval
Check the mechanical and electrical connections.	According to the guidelines of the machine's maintenance schedule, however, at least once every 1,000 operating hours.
Check the machine for smooth running, vibrations and bearing noises.	According to the guidelines of the machine's maintenance schedule, however, at least once every 1,000 operating hours.
Remove dust, chips and other dirt from the motor housing, cooling fins and the connections.	Depending on the degree of soiling, but after one operating year at the latest.

Fig. 13-1: Maintenance measures

**Repair** MKE must be repaired by the Rexroth service. The following repairs can be done by the Rexroth service for example:

- Replacement of motor encoder
- Replacement of the shaft sealing ring
- Repair / Change of damaged flameproof joints
- ...

# 14 Environmental Protection and Disposal

## 14.1 Environmental Protection

<b>Production Processes</b>	The products are made with energy- and resource-optimized production processes which allow re-using and recycling the resulting waste. We regularly try to replace pollutant-loaded raw materials and supplies by more environment-friendly alternatives.	
<b>No Release of Hazardous Substances</b>	Our products do not contain any hazardous substances which may be released in the case of appropriate use. Normally, our products will not have any negativ influences on the environment.	
<b>Significant Components</b>	Basically, our products contain the following components:	
	<b>Electronic devices</b> <ul style="list-style-type: none"> <li>• steel</li> <li>• aluminum</li> <li>• copper</li> <li>• synthetic materials</li> <li>• electronic components and modules</li> </ul>	<b>Motors</b> <ul style="list-style-type: none"> <li>• steel</li> <li>• aluminum</li> <li>• copper</li> <li>• brass</li> <li>• magnetic materials</li> <li>• electronic components and modules</li> </ul>

## 14.2 Disposal

<b>Return of Products</b>	<p>Our products can be returned to our premises free of charge for disposal. It is a precondition, however, that the products are free of oil, grease or other dirt. Furthermore, the products returned for disposal must not contain any undue foreign material or foreign components.</p> <p>Send the products "free domicile" to the following address:</p> <p style="text-align: center;">Bosch Rexroth AG Electric Drives and Controls Buergermeister-Dr.-Nebel-Strasse 2 97816 Lohr am Main, Germany</p>
<b>Packaging</b>	<p>The packaging materials consist of cardboard, wood and polystyrene. These materials can be recycled anywhere without any problem.</p> <p>For ecological reasons, please refrain from returning the empty packages to us.</p>
<b>Batteries and Accumulators</b>	<p>Batteries and accumulators can be labeled with this symbol.</p> <div style="text-align: center;">  </div> <p>The symbol indicating "separate collection" for all batteries and accumulators is the crossed-out wheeled bin.</p> <p>The end user within the EU is legally obligated to return used batteries. Outside the validity of the EU Directive 2006/66/EC keep the stipulated directives.</p> <p>Used batteries can contain hazardous substances, which can harm the environment or the people's health when they are improper stored or disposed of. After use, the batteries or accumulators contained in Rexroth products have to be properly disposed of according to the country-specific collection.</p>
<b>Recycling</b>	<p>Most of the products can be recycled due to their high content of metal. In order to recycle the metal in the best possible way, the products must be disassembled into individual modules.</p>

## Environmental Protection and Disposal

Metals contained in electric and electronic modules can also be recycled by means of special separation processes.

Products made of plastics can contain flame retardants. These plastic parts are labeled according to EN ISO 1043. They have to be recycled separately or disposed of according to the valid legal requirements.

# 15 Appendix

## 15.1 List of Standards

Document no.	Title	Edition
DIN 332-2	Center holes 60° with thread for shaft ends for rotating electrical machines	1983-05
DIN 748-1	Zylindric shaft end, dimensions, rated torque	1970-01
DIN 3760	Rotary shaft lip type seals	1996-09
DIN 6885-1	Drive Type Fastenings without Taper Action; Keys, Keyways, Deep Pattern	1968-08
DIN 42955	Tolerances of shaft extension run-out and of mounting flanges for rotating electrical machinery, test	1981-12
EN 60034-1	Rotating electrical machines - Part 1: Rating and performance (IEC 60034-1:2010, modified); German version EN 60034-1:2010 + Cor.:2010	2011-02
EN 60034-1 Corrigendum 1	Rotating electrical machines - Part 1: Rating and performance (IEC 60034-1:2004); German version EN 60034-1:2004, Corrigendum to DIN EN 60034-1 (VDE 0530-1):2005-04	2007-09
EN 60034-5	Rotating electrical machines - Part 5: Degrees of protection provided by integral design of rotating electrical machines (IP code) - Classification (IEC 60034-5:2000 + Corrigendum 2001 + A1:2006); German version EN 60034-5:2001 + A1:2007	2007-09
EN 60034-7	Rotating electrical machines - Part 7: Classification of types of construction, mounting arrangements and terminal box position (IM code) (IEC 60034-7:1992 + A1:2000); German version EN 60034-7:1993 + A1:2001	2001-12
EN 60034-14	Rotating electrical machines - Part 14: Mechanical vibration of certain machines with shaft heights 56 mm and higher - Measurement, evaluation and limits of vibration severity (IEC 60034-14:2003 + A1:2007); German version EN 60034-14:2004 + A1:2007	2008-03
EN 60068-2-6	Environmental testing - Part 2-6: Tests - Test Fc: Vibration (sinusoidal) (IEC 60068-2-6:2007); German version EN 60068-2-6:2008	2008-10
EN 60079-0	Explosive atmospheres - Part 0: Equipment - General requirements (IEC 60079-0:2009, modified); German version FprEN 60079-0:2009	2010-03
EN 60079-0 Corrigendum 1	Explosive atmospheres - Part 0: Equipment - General requirements (IEC 60079-0:2007); German version EN 60079-0:2009; Corrigendum to DIN EN 60079-0 (VDE 0170-1):2010-03; (IEC-Cor. :2010 about IEC 60079-0:2007)	2011-04
EN 60079-1	Electrical apparatus for explosive gas atmospheres - Part 1: Flameproof enclosures "d" (IEC 60079-1:2003); German version EN 60079-1:2004	2008-04
EN 60079-31	Explosive atmospheres -- Part 31: Equipment dust ignition protection by enclosure "t" (IEC 31/910/CD:2010)	2010-07
EN 60721-3-3	Classification of environmental conditions - Part 3: Classification of groups of environmental parameters and their severities; section 3: Stationary use at weatherprotected locations (IEC 60721-3-3:1994); German version EN 60721-3-3:1995	1995-09

## Appendix

Document no.	Title	Edition
EN 60721-3-3/A2	Classification of environmental conditions - Part 3: Classification of groups of environmental parameters and their severities; section 3: Stationary use at weatherprotected locations; Amendment A2 (IEC 60721-3-3:1994/A2:1996); German version EN 60721-3-3: 1995/A2:1997	1997-07
94/9/EG * 94/9/CE * 94/9/EC	Directive 94/9/EC of the European Parliament and the Council of 23 March 1994 on the approximation of the laws of the Member States concerning equipment and protective systems intended for use in potentially explosive atmospheres (OJ L100, 19.4.1994)	23.03.1994
94/9/EGBER * 94/9/CEBER * 94/9/ECBER	Corrigendum of Directive 94/9/EC of the European Parliament and the Council of 23 March 1994 on the approximation of the laws of the Member States concerning equipment and protective systems intended for use in potentially explosive atmospheres (OJ L100, 19.4.1994)	26.01.2000

*Fig.15-1: Standards*



## 15.2 Selection of Connection Cable

### 15.2.1 Power Cable IndraDyn S MKE

Motor	Controller		
	HCS□□.□□-□0012 HCS□□.□□-□0028 HMD□□.□□-□0012 HMD□□.□□-□0020 HMD□□.□□-□0036 HMS□□.□□-□0020 HMS□□.□□-□0028 HMS□□.□□-□0036	HCS□□.□□-□0054 HCS□□.□□-□0070 HMS□□.□□-□0054 HMS□□.□□-□0070	HCS□□.□□-□0100 HCS□□.□□-□0150 HMS□□.□□-□0110 HMS□□.□□-□0150 HMS□□.□□-□0210
MKE037B-144-□□□-□U□□	RKL4600	-	-
MKE037B-144-□□□-□E□□	IKG4145	RKL0008	-
MKE047B-144-□□□-□U□□	RKL4600	-	-
MKE047B-144-□□□-□E□□	IKG4145	RKL0008	-
MKE098B-047-□□□-□U□□	RKL4600	-	-
MKE098B-047-□□□-□E□□	IKG4145	RKL0008	-
MKE098B-058-□□□-□U□□	RKL4600	-	-
MKE098B-058-□□□-□E□□	IKG4145	RKL0008	-
MKE118B-024-□□□-KE4	IKG4146	IKG4148	RKL4781
MKE118B-024-□□□-□U□	RKL4602	RKL4603	-
MKE118B-058-□□□-KE4	IKG4146	IKG4148	RKL4781
MKE118B-058-□□□-KE6	-	IKG4149	-
MKE118B-058-□□□-□U□	-	IKG4149	-
MKE118D-012-□□□-□E4	IKG4146	IKG4148	RKL4781
MKE118D-012-□□□-□U□	-	RKL4606	RKL4607
MKE118D-027-□□□-□E4	IKG4146	IKG4148	RKL4781
MKE118D-027-□□□-□U□	-	RKL4606	RKL4607
MKE118D-035-□□□-□E6	-	IKG4149	-
MKE118D-035-□□□-□U□	-	RKL4606	RKL4607

Fig. 15-2: MKE power cable

**Ordering example** Then add the cable length to the order designation (.../xxx,x). Cables are available in lengths ranging from 2 to 75 m, in increments of 0.5 m.

Example:

Order code for a cable length of 25,5 m: **RKL4321/025,5**

## Appendix

## 15.2.2 Encoder cable IndraDyn S MKE

Motor	Encoder cable / type designation
MKE037□-□□□-A□□-□E□□	RKG0020
MKE037□-□□□-C□□-□E□□	
MKE047□-□□□-A□□-□E□□	
MKE047□-□□□-C□□-□E□□	
MKE098□-□□□-A□□-□E□□	
MKE098□-□□□-B□□-□E□□	
MKE098□-□□□-C□□-□E□□	
MKE098□-□□□-D□□-□E□□	
MKE118□-□□□-A□□-□E□□	RKG0022
MKE118□-□□□-B□□-□E□□	
MKE118□-□□□-C□□-□E□□	
MKE118□-□□□-D□□-□E□□	
MKE□□□□-□□□-A□□-□U□□	Single wires
MKE□□□□-□□□-B□□-□U□□	
MKE□□□□-□□□-C□□-□U□□	
MKE□□□□-□□□-D□□-□U□□	

Fig. 15-3: Encoder cable IndraDyn S MKE

# 15.3 Declaration of Conformity



**Konformitätserklärung**

Dok.-Nr.: TC30504-1  
Datum: 2012-05-10

nach Maschinenrichtlinie 2006/42/EG  
 nach Niederspannungsrichtlinie 2006/95/EG  
 nach EMV-Richtlinie 2004/108/EG  
 nach Druckgeräte-Richtlinie 97/23/EG  
 nach ATEX-Richtlinie 94/9/EG

Hiermit erklärt der Hersteller,  
 Bosch Rexroth Electric Drives and Controls GmbH  
 Bürgermeister-Dr.-Nebel-Straße 2  
 97816 Lohr a. Main / Germany

dass das nachstehende Produkt

Bezeichnung: Drehstrom-Synchronmotor  
 Typ: MKE037-...-E MKE047-...-E  
 MKE098-...-E MKE118-...-E

Ab Herstellungsdatum: 2012-07-01

in Übereinstimmung mit der oben genannten EU-Richtlinie entwickelt, konstruiert und gefertigt wurde.

Angewandte harmonisierte Normen:

Norm	Titel	Ausgabe
EN 60079-0	Explosionsfähige Atmosphäre – Teil 0: Geräte – Allgemeine Anforderungen	2009
EN 60079-1	Explosionsfähige Atmosphäre – Teil 1: Geräteschutz durch druckfeste Kapselung „d“	2007
EN 60079-31	Explosionsfähige Atmosphäre – Teil 31: Geräte-Staubexplosionsschutz durch Gehäuse „t“	2009

Der Motor hat folgende Kennzeichnung:  
 Ⓜ II 2G Ex d IIB T4 Gb X  
 Ⓜ II 2D Ex tc IIIC T135°C Dc IP6X X

Benannte Stelle, die das EG-Baumusterprüfverfahren nach oben genannter Richtlinie durchgeführt hat:

Name: Physikalisch-Technische Bundesanstalt (PTB)  
 Anschrift: Bundesallee 100, 38116 Braunschweig / Germany  
 Kennnummer: 0102  
 EG-Baumusterprüfbescheinigungs-Nr.: PTB 09 ATEX 1128 X (MKE037, MKE047, MKE098)  
 PTB 09 ATEX 1127 X (MKE118)

Weitere Erläuterungen:  
 Das Produkt ist ausschließlich zum Anbau in eine Maschine bestimmt.  
 Der bestimmungsgemäße Gebrauch des Produktes setzt die Einhaltung der Benutzungsbestimmungen und Anwendungsbedingungen, die in der Betriebsanleitung (MNR: R911323847) angegeben werden, durch den Nutzer voraus.

Lohr a. Main, den 2012-05-10 ppa.  i.V.   
 Ort Datum Werkleitung LoP2 Entwicklungsbereichsleiter Antriebe

Änderungen im Inhalt der Konformitätserklärung sind vorbehalten. Derzeit gültige Ausgabe auf Anfrage.

Seite 1 / 1

Fig. 15-4: Declaration of Conformity TC30504-1:2012-05-10 (original)



## 16 Service and Support

Our worldwide service network provides an optimized and efficient support. Our experts offer you advice and assistance should you have any queries. You can contact us **24/7**.

**Service Germany** Our technology-oriented Competence Center in Lohr, Germany, is responsible for all your service-related queries for electric drive and controls.

Contact the **Service Helpdesk & Hotline** under:

Phone:	<b>+49 9352 40 5060</b>
Fax:	<b>+49 9352 18 4941</b>
E-mail:	<a href="mailto:service.svc@boschrexroth.de">service.svc@boschrexroth.de</a>
Internet:	<a href="http://www.boschrexroth.com">http://www.boschrexroth.com</a>

Additional information on service, repair (e.g. delivery addresses) and training can be found on our internet sites.

**Service worldwide** Outside Germany, please contact your local service office first. For hotline numbers, refer to the sales office addresses on the internet.

**Preparing information** To be able to help you more quickly and efficiently, please have the following information ready:

- Detailed description of malfunction and circumstances resulting in the malfunction
- Type plate name of the affected products, in particular type codes and serial numbers
- Your contact data (phone and fax number as well as your email address)



# Index

## A

Accumulators.....	123
Ambient temperature.....	79
Ambient temperature in operation.....	25
ATEX	
Gearbox .....	67

## B

Balancing.....	82
Ball bearing pinion.....	90
Batteries.....	123
Bearing	
Wear .....	88
Bearing failure.....	88
Bearing lifetime.....	88
Braking energy.....	90

## C

Compatibility.....	79
Conditions of installation.....	80
Connection conditions.....	76
Connection time.....	26
Contained substances	
see "Significant components" .....	123
Continuous current at standstill.....	24
Continuous torque at standstill.....	24
Couplings.....	89

## D

Degree of protection.....	79
Degree of protection acc. to EN 60529.....	25
Design.....	7, 80
Design and components.....	6
Discharge capacity.....	24
Discharge time.....	121
Disconnection time.....	26
Disposal.....	123
Drive system.....	13
Duty cycle.....	23

## E

Electric drive system.....	13
Emergency stop.....	76
Encoder system.....	59
Environmental protection.....	123
External systems.....	8

## F

Fan.....	77
Flange assembly.....	107
Foreign materials.....	79

## G

Gearbox acc. to ATEX.....	67
Grease Lifetime.....	88
Grounding.....	76

## H

Hazardous substances.....	123
Helical teeth.....	90
Holding brake.....	
Commissioning .....	92
electrically-released .....	90
Holding brakes.....	90
Danger warning .....	91
Holding torque.....	25

## I

Identification.....	100
Inappropriate use.....	
Consequences, exclusion of liability .....	11
Installation altitude.....	79
Installation positions.....	80
Insulation class according to DIN EN 60034-1...	25
Intended use.....	11

## K

Key.....	81
Keyway.....	59

## M

Mass.....	25
Maximum current.....	24
Maximum torque.....	24
Maximum velocity.....	25
Mean speed.....	85
Moment of inertia of the brake.....	26
Motor assembly.....	107
Motorfeedback	
Encoder data memory .....	65
Motor paint	
Additional paint .....	80

## N

Number of pole pairs.....	25
---------------------------	----

## O

Operating modes.....	23
Output shaft.....	
Plain output shaft .....	81, 82
Plain output shaft .....	81

## P

Packaging.....	123
----------------	-----

## Index

**P**

PELV.....	17
Processing cycle.....	85
Production processes.....	123
Protective extra-low voltage.....	17

**R**

Radial force.....	88
Radial shaft sealing ring.....	23
radial shaft sealing rings.....	82
Rated current.....	26
Rated voltage.....	26
Recycling.....	123
Redundant bearing.....	89
Return of products.....	123
Risk of corrosion.....	76
Rotor moment of inertia.....	25

**S**

Safety instructions for electric drives and controls.....	13
Shaft	
plain .....	81
with keyway .....	81
Shaft sealing ring.....	82
Shock.....	81
Shock absorber.....	103
Significant components.....	123

**S**

Sinusoidal vibrations.....	80
Sling belts.....	103
Sound pressure level.....	25
Standards.....	8
state of the art.....	11
Support	
See service hotline .....	131

**T**

Temperature control.....	70
Thermal time constant.....	25
Tightness.....	83
Torque constant at 20°C.....	24

**U**

Use	
Inappropriate use .....	12
Intended use .....	11

**V**

Vibration.....	80
Voltage constant at 20°C.....	24

**W**

Winding inductivity.....	24
Winding resistance at 20 °C.....	24



# Notes

Bosch Rexroth AG  
Electric Drives and Controls  
Postfach 13 57  
97803 Lohr, Deutschland  
Bgm.-Dr.-Nebel-Str. 2  
97816 Lohr, Deutschland  
Tel. +49 9352 18 0  
Fax +49 9352 18 8400  
[www.boschrexroth.com/electrics](http://www.boschrexroth.com/electrics)



R911297663

DOK-MOTOR\*-MKE\*GEN2\*\*\*-PR06-EN-P